

EUROPEAN PATENT OFFICE
U.S. PATENT AND TRADEMARK OFFICE

CPC NOTICE OF CHANGES 1933

DATE: AUGUST 1, 2026

PROJECT RP11946

The following classification changes will be effected by this Notice of Changes:

<u>Action</u>	<u>Subclass</u>	<u>Group(s)</u>
SCHEME:		
Symbols Deleted:	A61M	2005/14256, 2005/16863, 2005/16868, 2005/16872, 2005/206, 2005/31598
	A61M	2039/1033, 2039/229
Symbols New:	A61M	5/009, 5/0091, 5/16863, 5/206, 5/3147, 5/31598, 5/32021, 5/32023, 5/320231, 5/320233, 5/320235, 5/32025, 5/320253, 5/320255, 5/32027, 5/32029
	A61M	39/1033, 39/229
Titles Changed:	A61M	5/00, 5/002, 5/008, 5/1408, 5/1409, 5/1411, 5/145, 5/148, 5/152, 5/1582, 2005/1588, 5/162, 5/165, 5/168, 5/16804, 5/16809, 5/16836, 5/16877, 5/16881, 5/172, 5/1723, 5/19, 5/20, 5/24, 2005/3125, 2005/3126, 5/3129, 5/3137, 5/31576, 5/31578, 5/3158, 5/31581, 5/31583, 5/31585, 5/31586, 5/32, 5/3202, 5/3204
	A61M	39/00, 39/0208, 39/0247, 39/10, 39/1055
Warnings New:	A61M	5/00, 5/009, 5/31, 2005/3125, 2005/3126, 5/3137, 2005/3139, 5/3147, 5/3155, 5/31551, 5/31553, 5/3202, 5/32021, 5/32023, 5/32027, 5/32029, 5/3204
Warnings Deleted:	A61M	39/00
DEFINITIONS:		

CPC NOTICE OF CHANGES 1933

DATE: AUGUST 1, 2026

PROJECT RP11946

<u>Action</u>	<u>Subclass</u>	<u>Group(s)</u>
Definitions New:	A61M	5/001, 5/002, 5/003, 2005/004, 2005/005, 2005/006, 5/007, 5/008, 5/14, 2005/1402, 2005/1403, 2005/1404, 2005/1405, 2005/1406, 5/1408, 5/1409, 5/141, 5/1411, 5/1412, 5/1413, 5/1414, 5/1415, 2005/1416, 5/1417, 5/1418, 5/142, 2005/14204, 2005/14208, 5/14212, 5/14216, 5/1422, 5/14224, 5/14236, 5/1424, 5/14244, 5/14248, 2005/14252, 2005/1426, 2005/14264, 2005/14268, 2005/14272, 5/14276, 5/1428, 2005/14284, 2005/14292, 2005/14296, 5/145, 2005/14506, 2005/14513, 5/1452, 5/14526, 2005/14533, 5/1454, 5/14546, 2005/14553, 5/1456, 5/14566, 2005/14573, 5/1458, 5/14586, 5/14593, 5/148, 5/1483, 5/1486, 5/152, 5/155, 5/158, 2005/1581, 5/1582, 2005/1583, 2005/1585, 2005/1587, 2005/1588, 5/162, 2005/1623, 5/1626, 5/165, 5/168, 5/16804, 5/16809, 5/16813, 5/16818, 5/16822, 5/16827, 5/16836, 5/1684, 5/16845, 5/1685, 5/16854, 5/16859, 5/16863, 5/16877, 5/16881, 5/16886, 5/1689, 5/16895, 5/172, 5/1723, 2005/1726, 5/1782, 5/1785, 2005/1787, 5/19, 5/20, 2005/2013, 2005/202, 2005/2026, 5/2033, 5/2046, 5/2053, 5/206, 5/2066, 2005/208, 5/24, 5/2448, 5/28, 5/284, 2005/3022, 2005/3103, 2005/3117, 2005/3131, 5/3135, 5/3137, 5/3153, 5/31578, 5/3158, 5/31581, 5/31583, 5/31585, 5/31586, 5/32, 5/3202, 5/32023, 5/321, 2005/3253, 5/3257, 5/326, 2005/3267, 5/3287, 5/422
	A61M	2039/0009, 2039/0018, 2039/0027, 2039/0036, 2039/0045, 2039/0063, 2039/0072, 2039/0081, 2039/009, 39/02, 39/0208, 39/0247, 39/04, 39/045, 39/06, 39/0606, 39/0613, 2039/0633, 2039/064, 2039/0646, 2039/0653, 2039/066, 2039/0666, 2039/0673, 39/0693, 39/08, 2039/087, 39/10, 39/1011, 2039/1027, 39/1033, 2039/1038, 39/1055, 2039/1061, 2039/1066, 2039/1077, 2039/1094, 39/12, 39/14, 39/221, 2039/222, 39/223, 2039/224, 39/225, 2039/226, 39/229, 39/24, 2039/2493, 2039/261, 2039/263, 39/284
Definitions Modified:	A61M	5/00, 5/14228, 5/14232, 2005/14288, 2005/1586

CPC NOTICE OF CHANGES 1933

DATE: AUGUST 1, 2026

PROJECT RP11946

<u>Action</u>	<u>Subclass</u>	<u>Group(s)</u>
	A61M	39/00, 2039/085

The following subclasses are also impacted by this project: A61J

This Notice of Changes includes the following [Check the ones included]:

1. CLASSIFICATION SCHEME CHANGES

- A. New, Modified or Deleted Group(s)
- B. New, Modified or Deleted Warning(s)
- C. New, Modified or Deleted Note(s)
- D. New, Modified or Deleted Guidance Heading(s)

2. DEFINITIONS

- A. New or Modified Definitions (Full definition template)
- B. Modified or Deleted Definitions (Definitions Quick Fix)

- 3. REVISION CONCORDANCE LIST (RCL)
- 4. CHANGES TO THE CPC-TO-IPC CONCORDANCE LIST (CICL)
- 5. CHANGES TO THE CROSS-REFERENCE LIST (CRL)

CPC NOTICE OF CHANGES 1933

DATE: AUGUST 1, 2026

PROJECT RP11946

1. CLASSIFICATION SCHEME CHANGES

A. New, Modified or Deleted Group(s)

SUBCLASS: A61M - DEVICES FOR INTRODUCING MEDIA INTO, OR ONTO, THE BODY; DEVICES FOR TRANSDUCING BODY MEDIA OR FOR TAKING MEDIA FROM THE BODY; DEVICES FOR PRODUCING OR ENDING SLEEP OR STUPOR

<u>Type*</u>	<u>Symbol</u>	<u>Indent Level Number of dots (e.g. 0, 1, 2)</u>	<u>Title</u> <u>“CPC only” text should normally be enclosed in {curly brackets}**</u>	<u>Transferred to</u>
C	A61M 5/00	0	Devices for bringing media into the body in a subcutaneous, intra-vascular or intramuscular way; Accessories therefor, e.g. filling or cleaning devices, arm rests (tube connectors, tube couplings, valves or branch units, specially adapted for medical use A61M 39/00; containers specially adapted for medical or pharmaceutical purposes A61J 1/00)	A61M 5/00, A61M 5/009, A61M 5/0091
M	A61M 5/002	1	{Packages specially adapted therefor, e.g. packages for syringes or needles or kits for diabetics}	
M	A61M 5/008	1	{Racks for supporting syringes or needles}	
N	A61M 5/009	1	{Electronic or electro-mechanical add-on modules}	
N	A61M 5/0091	2	{Rotatable add-on modules}	
U	A61M 5/1407	2	{Infusion of two or more substances}	
M	A61M 5/1408	3	{in parallel, e.g. by manifolds or with sequencing valves}	
M	A61M 5/1409	3	{in series, e.g. reconstitution systems with a first substance passing through a container holding a second substance}	
M	A61M 5/1411	2	{Drip chambers (A61M 5/1689, A61M 5/40 take precedence)}	
T	A61M 2005/14252	5	{with needle insertion means}	
D	A61M 2005/14256	6	{with means for preventing access to the needle after use}	<administrative transfer to A61M 2005/1426 and A61M 2005/14252 simultaneously >
T	A61M 2005/1426	5	{with means for preventing access to the needle after use}	
M	A61M 5/145	3	using pressurised reservoirs, e.g. by means of pistons	
M	A61M 5/148	4	flexible (A61M 5/155 takes precedence)	
M	A61M 5/152	5	pressurised by contraction of elastic reservoirs	

CPC NOTICE OF CHANGES 1933

DATE: AUGUST 1, 2026

PROJECT RP11946

<u>Type*</u>	<u>Symbol</u>	<u>Indent Level Number of dots (e.g. 0, 1, 2)</u>	<u>Title</u> <u>“CPC only” text should normally be enclosed in {curly brackets}**</u>	<u>Transferred to</u>
M	A61M 5/1582	3	{Multi-lumen needles}	
M	A61M2005/1588	3	{having means for monitoring, controlling or visual inspection, e.g. for patency check or for avoiding extravasation}	
M	A61M 5/162	2	Needle sets, i.e. connections by puncture between reservoir and tube	
M	A61M 5/165	2	Filtering accessories, e.g. blood filters, filters for infusion liquids (A61M 1/34, A61M 5/36 take precedence)	
M	A61M 5/168	2	Means for controlling media flow to the body or for metering media to the body, e.g. drip meters, counters	
M	A61M 5/16804	3	{Active flow controllers}	
M	A61M 5/16809	4	{by repeated filling and emptying of an intermediate volume}	
U	A61M 5/16813	4	{by controlling the degree of opening of the flow line}	
M	A61M 5/16836	4	{by sensing tissue properties at the infusion site, e.g. for detecting infiltration}	
N	A61M 5/16863	4	{Occlusion detection}	
D	A61M 2005/16863	4	{Occlusion detection}	<administrative transfer to A61M 5/16863>
D	A61M 2005/16868	5	{Downstream occlusion sensors}	<administrative transfer to A61M 5/16863>
D	A61M 2005/16872	5	{Upstream occlusion sensors}	<administrative transfer to A61M 5/16863>
M	A61M 5/16877	3	{Passive flow controllers; Devices for setting a flow rate (clamp-type valves A61M 39/28)}	
M	A61M 5/16881	4	{Regulating valves}	
M	A61M 5/172	3	electrical or electronic	
M	A61M 5/1723	4	{using feedback of body parameters, e.g. blood sugar or pressure}	
M	A61M 5/19	2	having more than one chamber	
M	A61M 5/20	2	Automatic syringes, e.g. with automatically actuated piston rod, with automatic needle injection, filling automatically (A61M 5/142 takes precedence)	
D	A61M 2005/206	3	{With automatic needle insertion}	<administrative transfer to A61M 5/206>
N	A61M 5/206	3	{with automatic needle insertion}	

CPC NOTICE OF CHANGES 1933

DATE: AUGUST 1, 2026

PROJECT RP11946

<u>Type*</u>	<u>Symbol</u>	<u>Indent Level Number of dots (e.g. 0, 1, 2)</u>	<u>Title</u> <u>“CPC only” text should normally be enclosed in {curly brackets}**</u>	<u>Transferred to</u>
U	A61M 2005/2093	3	{including concentration setting means}	
M	A61M 5/24	2	Ampoule syringes, i.e. syringes with needle for use in combination with replaceable ampoules or cartridges, e.g. automatic	
U	A61M 2005/3022	3	{Worn on the body, e.g. as patches (pressure infusion of the skin patch type A61M 5/14248)}	
C	A61M 5/31	2	Details	A61M 5/31, A61M 5/3147
C	A61M 2005/3125	3	{Display means, e.g. to indicate dose setting}	A61M 2005/3125, A61M 5/3147
C	A61M 2005/3126	4	{related to dosing}	A61M 2005/3126, A61M 5/3155, A61M 5/009, A61M 5/0091
M	A61M 5/3129	3	{Syringe barrels (A61M 5/3205, A61M 5/50 take precedence)}	
C	A61M 5/3137	4	{with finger grip means, e.g. for easy manipulation of the syringe rod}	A61M 5/3137, A61M 5/3147
C	A61M 2005/3139	5	{Finger grips not integrally formed with the syringe barrel, e.g. using adapter with finger grips}	A61M 2005/3139, A61M 5/3147
U	A61M 5/3146	3	{Priming, e.g. purging, reducing backlash or clearance}	
N	A61M 5/3147	3	{Syringe accessories}	
C	A61M 5/3155	7	{by rotational movement of dose setting member, e.g. during setting or filling of a syringe}	A61M 5/3155, A61M 5/009, A61M 5/0091
C	A61M 5/31551	8	{including axial movement of dose setting member}	A61M 5/31551, A61M 5/009, A61M 5/0091
C	A61M 5/31553	8	{without axial movement of dose setting member}	A61M 5/31553, A61M 5/009, A61M 5/0091
M	A61M 5/31576	5	{Constructional features; Drive mechanisms or modes for piston rods}	
M	A61M 5/31578	6	{the piston rod being moved by the axial movement of a component directly in contact with it}	
M	A61M 5/3158	7	{the component being manually operated or triggered by an axially moving actuator operated by user, e.g. an axially movable injection button}	

CPC NOTICE OF CHANGES 1933

DATE: AUGUST 1, 2026

PROJECT RP11946

<u>Type*</u>	<u>Symbol</u>	<u>Indent Level Number of dots (e.g. 0, 1, 2)</u>	<u>Title</u> <u>“CPC only” text should normally be enclosed in {curly brackets}**</u>	<u>Transferred to</u>
M	A61M 5/31581	7	{the component being manually operated or triggered by a rotating or pivoting actuator operated by user, e.g. an injection lever or handle}	
M	A61M 5/31583	6	{the piston rod being moved by the rotational movement of a component directly in contact with it}	
M	A61M 5/31585	7	{the component being manually operated or triggered by an axially moving actuator operated by user, e.g. an axially movable injection button}	
M	A61M 5/31586	7	{the component being manually operated or triggered by a rotating or pivoting actuator operated by user, e.g. an injection lever or handle}	
N	A61M 5/31598	5	{having multiple telescopically sliding coaxial pistons encompassing volumes for components to be mixed}	
D	A61M 2005/31598	5	{having multiple telescopically sliding coaxial pistons encompassing volumes for components to be mixed}	<administrative transfer to A61M 5/31598>
M	A61M 5/32	3	Needles; Details of needles pertaining to their connection with syringe or hub (infusion needles A61M 5/158); Accessories for bringing the needle into, or holding the needle on, the body; Devices for protection of needles	
C	A61M 5/3202	4	{Devices for protection of the needle before use, e.g. caps (A61M 5/50 takes precedence; protectors for sharps A61B 50/3001)}	A61M 5/3202, A61M 5/32021, A61M 5/32023, A61M 5/320231, A61M 5/320233, A61M 5/320235, A61M 5/32025, A61M 5/320253, A61M 5/320255, A61M 5/32027, A61M 5/32029
N	A61M 5/32021	5	{Caps made of two or more materials}	
N	A61M 5/32023	5	{Caps having a secondary function besides protecting the needle, e.g. sealing the needle lumen or blocking injector activation}	
N	A61M 5/320231	6	{Means for removing the cap}	
N	A61M 5/320233	7	{actuated by twisting}	
N	A61M 5/320235	7	{actuated by pushing}	

CPC NOTICE OF CHANGES 1933

DATE: AUGUST 1, 2026

PROJECT RP11946

<u>Type*</u>	<u>Symbol</u>	<u>Indent Level Number of dots (e.g. 0, 1, 2)</u>	<u>Title</u> <u>“CPC only” text should normally be enclosed in {curly brackets}**</u>	<u>Transferred to</u>
N	A61M 5/32025	6	{Preventing accidental removal of the cap}	
N	A61M 5/320253	6	{Preventing premature or accidental actuation of the injector}	
N	A61M 5/320255	6	{Preventing re-capping}	
N	A61M 5/32027	5	{with electronic components}	
N	A61M 5/32029	5	{Caps made of two or more separable parts}	
C	A61M 5/3204	5	{Needle cap removers, i.e. devices to dislodge protection cover from needle or needle hub, e.g. deshielding devices}	A61M 5/3204, A61M 5/32021, A61M 5/32023, A61M 5/320231, A61M 5/320233, A61M 5/320235, A61M 5/32025, A61M 5/320253, A61M 5/320255, A61M 5/32027, A61M 5/32029
M	A61M 39/00	0	Tubes, tube connectors, tube couplings, valves, access sites or the like, specially adapted for medical use (for respiratory devices, e.g. tracheal tubes, A61M 16/00; artificial heart valves A61F 2/24)	
U	A61M 39/02	1	Access sites	
M	A61M 39/0208	2	{Subcutaneous access sites (implantable infusion devices A61M 5/14276; transcutaneous access sites A61M 39/0247)}	
M	A61M 39/0247	2	{Transcutaneous or percutaneous access sites to the inside of the body}	
M	A61M 39/10	1	Tube connectors or tube couplings	
N	A61M 39/1033	2	{Swivel nut connectors, e.g. threaded connectors or bayonet-connectors}	
D	A61M 2039/1033	2	{Swivel nut connectors, e.g. threaded connectors, bayonet-connectors}	<administrative transfer to A61M 39/1033>
M	A61M 39/1055	2	{Rotating or swivel joints}	
N	A61M 39/229	2	{Single-way cut-off valves}	
D	A61M 2039/229	2	{Stopcocks}	<administrative transfer to A61M 39/229>

*N = new entries where reclassification into entries is involved; C = entries with modified file scope where reclassification of documents from the entries is involved; Q = new entries which are firstly populated with documents via administrative transfers from deleted (D) entries. Afterwards, the transferred documents into the Q entry will either stay or be moved to more appropriate entries, as determined by intellectual reclassification; T = existing entries with enlarged file scope, which receive documents from C or D entries, e.g. when a limiting reference is removed from the entry title; M = entries with no change to the file scope (no

CPC NOTICE OF CHANGES 1933

DATE: AUGUST 1, 2026

PROJECT RP11946

reclassification); D = deleted entries; F = frozen entries will be deleted once reclassification of documents from the entries is completed; U = entries that are unchanged.

NOTES:

- **No {curly brackets} are used for titles in CPC only subclasses, e.g. C12Y, A23Y; 2000 series symbol titles of groups found at the end of schemes (orthogonal codes); or the Y section titles. The {curly brackets} are used for 2000 series symbol titles found interspersed throughout the main trunk schemes (breakdown codes).
- U groups: it is obligatory to display the required “anchor” symbol (U group), i.e. the entry immediately preceding a new group or an array of new groups to be created (in case new groups are not clearly subgroups of C-type groups). Always include the symbol, indent level and title of the U group in the table above.
- All entry types should be included in the scheme changes table above for better understanding of the overall scheme change picture. Symbol, indent level, and title are required for all types.
- “Transferred to” column must be completed for all C, D, F, and Q type entries. F groups will be deleted once reclassification is completed.
- When multiple symbols are included in the “Transferred to” column, avoid using ranges of symbols in order to be as precise as possible.
- For administrative transfer of documents, the following text should be used: “< administrative transfer to XX>”, “<administrative transfer to XX and YY simultaneously>”, or “<administrative transfer to XX, YY, ...and ZZ simultaneously>” when administrative transfer of the same documents is to more than one place.
- Administrative transfer to main trunk groups is assumed to be the source allocation type, unless otherwise indicated.
- Administrative transfer to 2000/Y series groups is assumed to be “additional information”.
- If needed, instructions for allocation type should be indicated within the angle brackets using the abbreviations “ADD” or “INV”: <administrative transfer to XX ADD>, <administrative transfer to XX INV>, or < administrative transfer to XX ADD, YY INV, ... and ZZ ADD simultaneously>.
- In certain situations, the “D” entries of 2000-series or Y-series groups may not require a destination (“Transferred to”) symbol, however it is required to specify “<no transfer>” in the “Transferred to” column for such cases.
- For finalisation projects, the deleted “F” symbols should have <no transfer> in the “Transferred to” column.
- For more details about the types of scheme change, see CPC Guide.

CPC NOTICE OF CHANGES 1933

DATE: AUGUST 1, 2026

PROJECT RP11946

B. New, Modified or Deleted Warning(s)

SUBCLASS A61M - DEVICES FOR INTRODUCING MEDIA INTO, OR ONTO, THE BODY; DEVICES FOR TRANSDUCING BODY MEDIA OR FOR TAKING MEDIA FROM THE BODY; DEVICES FOR PRODUCING OR ENDING SLEEP OR STUPOR

<u>Type*</u>	<u>Location</u>	<u>Old Warning</u>	<u>New/Modified Warning</u>
N	A61M 5/00		Group A61M 5/00 is impacted by reclassification into groups A61M 5/009 and A61M 5/0091. Groups A61M 5/00, A61M 5/009 and A61M 5/0091 should be considered in order to perform a complete search.
N	A61M 5/009		Groups A61M 5/009 and A61M 5/0091 are incomplete pending reclassification of documents from groups A61M 5/00, A61M 2005/3126, A61M 5/3155, A61M 5/31551 and A61M 5/31553. All groups listed in this Warning should be considered in order to perform a complete search.
N	A61M 5/31		Group A61M 5/31 is impacted by reclassification into group A61M 5/3147. Groups A61M 5/31 and A61M 5/3147 should be considered in order to perform a complete search.
N	A61M 2005/3125		Group A61M 2005/3125 is impacted by reclassification into group A61M 5/3147. Groups A61M 2005/3125 and A61M 5/3147 should be considered in order to perform a complete search.
N	A61M 2005/3126		Group A61M 2005/3126 is impacted by reclassification into groups A61M 5/3155, A61M 5/009 and A61M 5/0091. All groups listed in this Warning should be considered in order to perform a complete search.
N	A61M 5/3137		Group A61M 5/3137 is impacted by reclassification into group A61M 5/3147. Groups A61M 5/3137 and A61M 5/3147 should be considered in order to perform a complete search.
N	A61M 2005/3139		Group A61M 2005/3139 is impacted by reclassification into group A61M 5/3147. Groups A61M 2005/3139 and A61M 5/3147 should be

CPC NOTICE OF CHANGES 1933

DATE: AUGUST 1, 2026

PROJECT RP11946

<u>Type*</u>	<u>Location</u>	<u>Old Warning</u>	<u>New/Modified Warning</u>
			considered in order to perform a complete search.
N	A61M 5/3147		Group A61M 5/3147 is incomplete pending reclassification of documents from groups A61M 5/31, A61M 2005/3125, A61M 5/3137 and A61M 2005/3139. All groups listed in this Warning should be considered in order to perform a complete search.
N	A61M 5/3155		Group A61M 5/3155 is incomplete pending reclassification of documents from group A61M 2005/3126. Group A61M 5/3155 is also impacted by reclassification into groups A61M 5/009 and A61M 5/0091. All groups listed in this Warning should be considered in order to perform a complete search.
N	A61M 5/31551		Group A61M 5/31551 is impacted by reclassification into groups A61M 5/009 and A61M 5/0091. Groups A61M 5/31551, A61M 5/009 and A61M 5/0091 should be considered in order to perform a complete search.
N	A61M 5/31553		Group A61M 5/31553 is impacted by reclassification into groups A61M 5/009 and A61M 5/0091. Groups A61M 5/31553, A61M 5/009 and A61M 5/0091 should be considered in order to perform a complete search.
N	A61M 5/3202		Group A61M 5/3202 is impacted by reclassification into groups A61M 5/32021, A61M 5/32023, A61M 5/320231, A61M 5/320233, A61M 5/320235, A61M 5/32025, A61M 5/320253, A61M 5/320255, A61M 5/32027 and A61M 5/32029. All groups listed in this Warning should be considered in order to perform a complete search.
N	A61M 5/32021		Group A61M 5/32021 is incomplete pending reclassification of documents from groups A61M 5/3202 and A61M 5/3204. Groups A61M 5/3202, A61M 5/3204 and A61M 5/32021 should be considered in order to perform a complete search.

CPC NOTICE OF CHANGES 1933

DATE: AUGUST 1, 2026

PROJECT RP11946

<u>Type*</u>	<u>Location</u>	<u>Old Warning</u>	<u>New/Modified Warning</u>
N	A61M 5/32023		Groups A61M 5/32023, A61M 5/320231, A61M 5/320233, A61M 5/320235, A61M 5/32025, A61M 5/320253 and A61M 5/320255 are incomplete pending reclassification of documents from groups A61M 5/3202 and A61M 5/3204. All groups listed in this Warning should be considered in order to perform a complete search.
N	A61M 5/32027		Group A61M 5/32027 is incomplete pending reclassification of documents from groups A61M 5/3202 and A61M 5/3204. Groups A61M 5/3202, A61M 5/3204 and A61M 5/32027 should be considered in order to perform a complete search.
N	A61M 5/32029		Group A61M 5/32029 is incomplete pending reclassification of documents from groups A61M 5/3202 and A61M 5/3204. Groups A61M 5/3202, A61M 5/3204 and A61M 5/32029 should be considered in order to perform a complete search.
N	A61M 5/3204		Group A61M 5/3204 is impacted by reclassification into groups A61M 5/32021, A61M 5/32023, A61M 5/320231, A61M 5/320233, A61M 5/320235, A61M 5/32025, A61M 5/320253, A61M 5/320255, A61M 5/32027 and A61M 5/32029. All groups listed in this Warning should be considered in order to perform a complete search.
D	A61M 39/00	Not complete, see A61J 1/14	<u>Delete</u> entire Warning.

*N = new warning, M = modified warning, D = deleted warning

NOTE: The "Location" column only requires the symbol PRIOR to the location of the warning. No further directions such as "before" or "after" are required.

2. A. DEFINITIONS (new)

A61M 5/001

Definition statement

This place covers:

Cleaning or sterilising apparatuses for syringes or needles.

Infusion and injection devices with dedicated features relating to cleaning or sterilising syringes or needles comprised in the device.

Packaging which allows for sterilisation of enclosed devices.

References

Informative references

Attention is drawn to the following places, which might be of interest for search:

Methods or apparatus for disinfecting or sterilising materials or objects other than foodstuffs or contact lenses; Accessories therefor	A61L 2/00
---	---------------------------

Special rules of classification

Packaging must additionally be classified in group [A61M 5/002](#) or subgroups.

A61M 5/002

Definition statement

This place covers:

Packaging, such as pouches, cases, containers for infusion and injection devices, which may be used for storage, transportation, sterilisation or during use of the device.

References

Informative references

Attention is drawn to the following places, which might be of interest for search:

Needle protection, e.g. caps	A61M 5/3202
For sharps	A61B 50/3001
Machines, apparatus or device for, or methods of, packaging articles or materials; Unpacking	B65B

A61M 5/003

Definition statement

This place covers:

Sets comprising infusion or injection equipment used by a diabetic. Typically, these sets are comprised within a case.

Illustrative example of subject matter classified in this place:

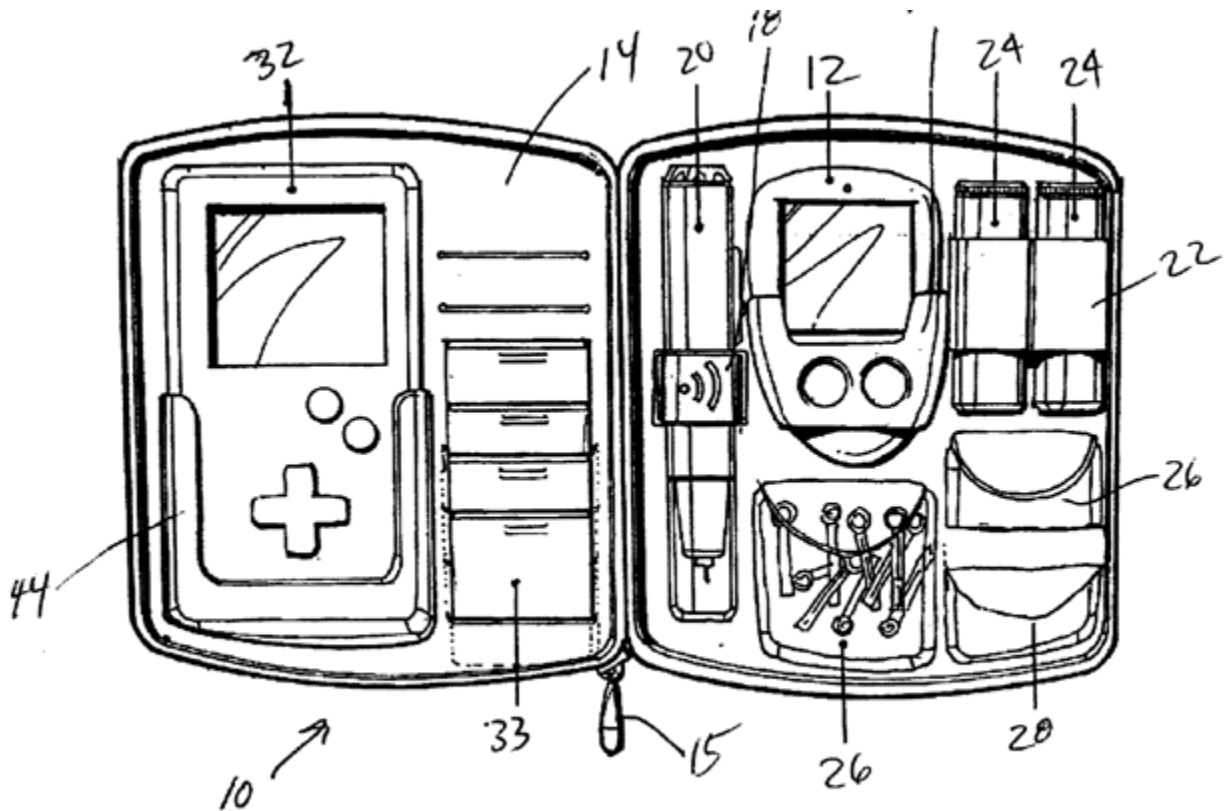

DATE: AUGUST 1, 2026

PROJECT RP11946

References

Informative references

Attention is drawn to the following places, which may be of interest for search:

Pressure infusion, e.g. using pumps	A61M 5/142
Automatic syringes, e.g. with automatically actuated piston rod, with automatic needle injection, filling automatically	A61M 5/20
Devices for taking blood samples by lancets	A61B 5/1411
Devices for measuring glucose	A61B 5/14532

A61M 2005/004

Definition statement

This place covers:

Multiple needle magazines insertable into an infusion or injection device.

Magazines that allow for direct attachment of the needle to the infusion or injection device from the magazine.

Illustrative examples of subject matter classified in this place:

1.

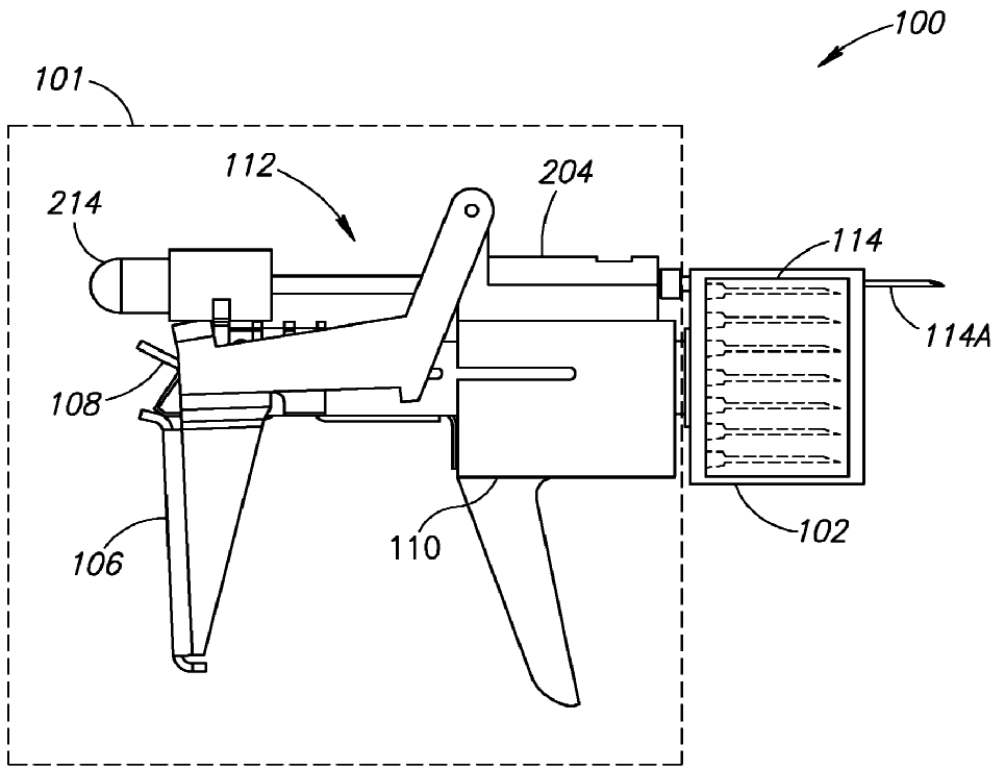

2.

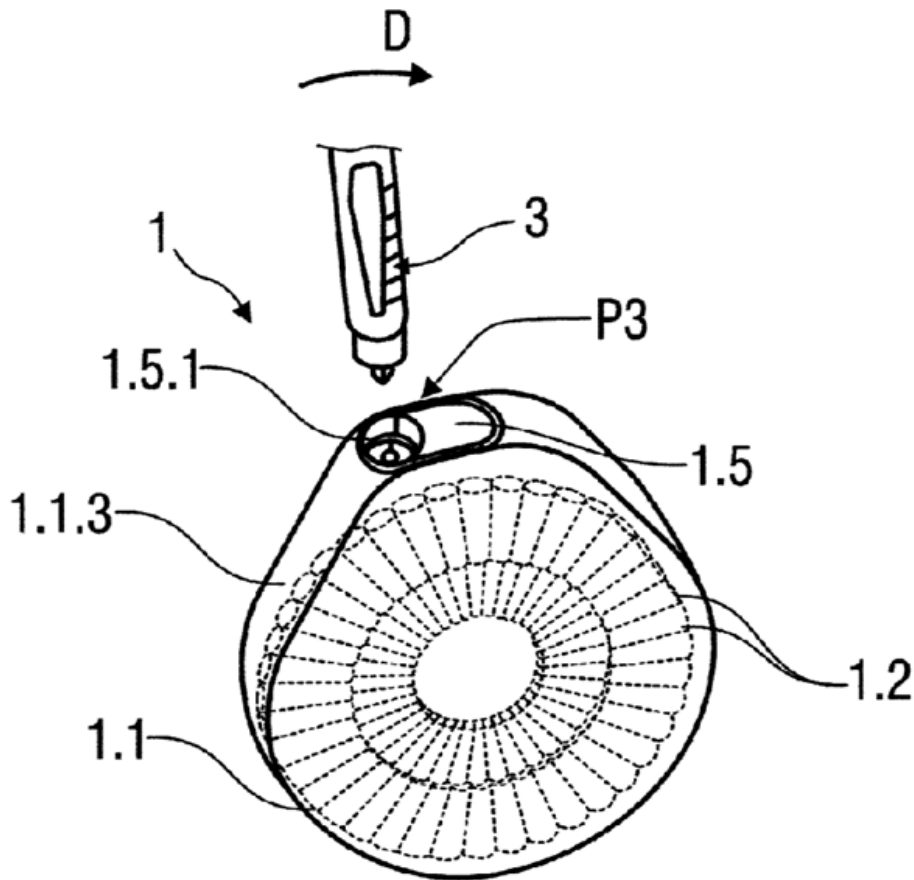

References

Informative references

Attention is drawn to the following places, which might be of interest for search:

Vaccination appliances for veterinary use	A61D 1/025
Devices or methods for introducing solid, liquid or gaseous remedies or other materials into or onto the bodies of animals	A61D 7/00

A61M 2005/005

Definition statement

This place covers:

Multiple ampoule magazines insertable into an infusion or injection device.

Magazines that allow for direct attachment of the ampoule, cartridge or the like to the infusion or injection device from the magazine.

Illustrative example of subject matter classified in this place:

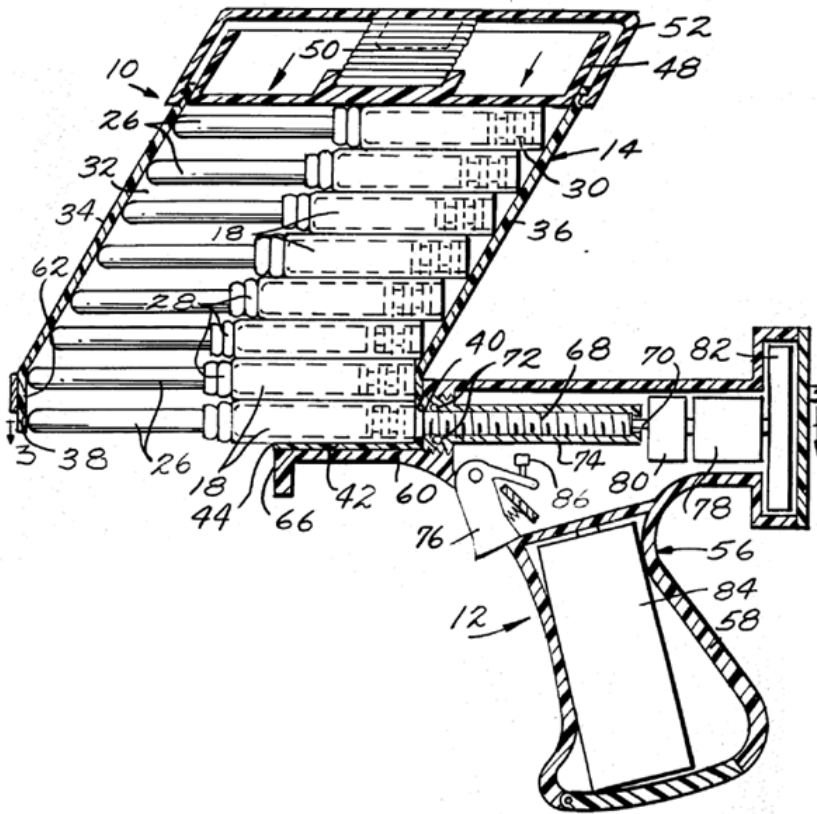

DATE: AUGUST 1, 2026

PROJECT RP11946

A61M 2005/006

Definition statement

This place covers:

Devices or arrangements that relate to the infusion of gases in a subcutaneous, intra-vascular or intramuscular way.

A61M 5/007

Definition statement

This place covers:

Apparatus with features particular to contrast media infusion.

References

Informative references

Attention is drawn to the following places, which might be of interest for search:

Diagnostic techniques involving the use of contrast agents	A61B 6/481
X-ray contrast preparations	A61K 49/04
Details of apparatus provided in G01R33/44 - G01R33/64	G01R 33/28
Arrangements or instruments for measuring magnetic variables using MNR	G01R 33/44
Arrangements or instruments for measuring magnetic variables using cyclotron resonance	G01R 33/64

A61M 5/008

Definition statement

This place covers:

Racks for injection devices, such as syringes or needles.

Syringe trays.

Racks such as support stands or equipment for holding usually several injection devices.

Illustrative example of subject matter classified in this place:

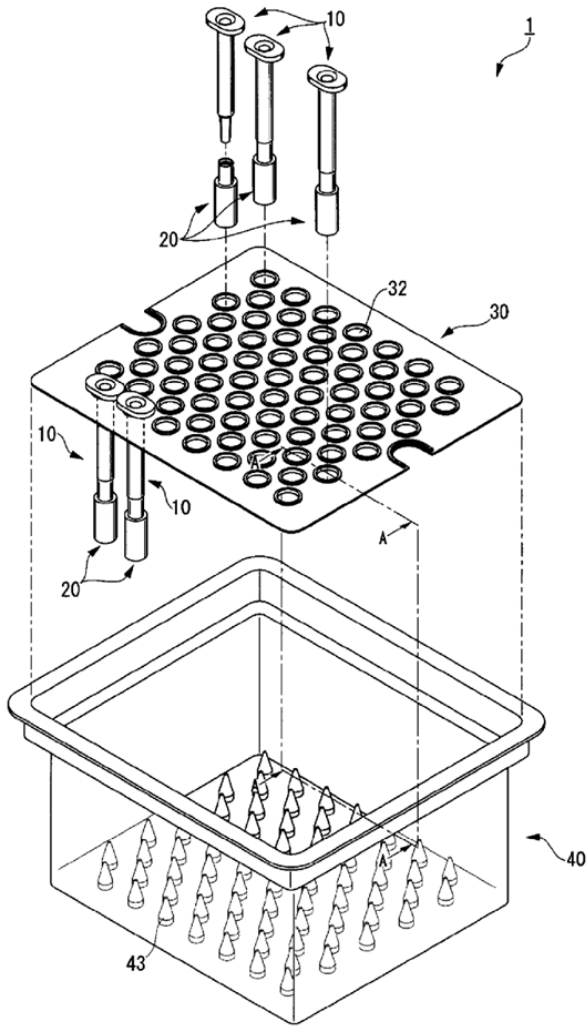

References

Informative references

Attention is drawn to the following places, which might be of interest for search:

Apparatus for cleaning or sterilising syringes or needles	A61M 5/001
Packaging equipment	A61M 5/002

DATE: AUGUST 1, 2026

PROJECT RP11946

Racks and stands for infusion devices	A61M 5/1415
---------------------------------------	-----------------------------

A61M 5/14

Definition statement

This place covers:

Infusion devices used to administer media (usually a liquid) to a patient, usually over a prolonged period of time, and from a reservoir that may be replaced during the infusion process.

A61M 2005/1402

Definition statement

This place covers:

Particular aspects related to the priming (i.e. initial filling) of an infusion device or arrangement.

A61M 2005/1403

Definition statement

This place covers:

Particular aspects related to flushing or purging of an infusion device or arrangement. Flushing may be performed to decontaminate a device or arrangement by using a saline fluid. Purging may be performed to get rid of air (or other undesired fluids) in an infusion device or arrangement.

DATE: AUGUST 1, 2026

PROJECT RP11946

A61M 2005/1404

Definition statement

This place covers:

Particular aspects related to particularly low flow rates that are employed to prevent closure of an infusion line or access site.

A61M 2005/1405

Definition statement

This place covers:

Particular aspects related to patient-controlled pain reduction devices or arrangements.

A61M 2005/1406

Definition statement

This place covers:

Particular aspects regarding the reduction or prevention of backflow in a catheter (i.e. in the infusion needle or infusion line).

A61M 5/1408

Definition statement

This place covers:

Parallel infusion from parallel reservoirs, out of which also a sequential infusion may be administered by respective actuation of a sequencing valve or similar.

References

Informative references

DATE: AUGUST 1, 2026

PROJECT RP11946

Attention is drawn to the following places, which might be of interest for search:

Access sites	A61M 39/02
Tube connectors	A61M 39/10
Needle sets	A61M 5/162

A61M 5/1409

Definition statement

This place covers:

Serial infusion from a serial arrangement of reservoirs, in which one liquid usually flows into or passes through the other reservoir upon administration.

References

Informative references

Attention is drawn to the following places, which might be of interest for search:

Needle sets	A61M 5/162
Access sites	A61M 39/02
Tube connectors	A61M 39/10

A61M 5/141

Definition statement

This place covers:

Infusion devices with capillary or a similar flow restrictor, having a significant flow resistance achieved by providing a conduit of small diameter and certain length (i.e. governed by the Hagen-Poiseuille law).

A61M 5/1411

Definition statement

This place covers:

Drip chambers connected to an infusion source and that allow gas (such as air) to rise out from the infusion liquid so that it is not passed downstream. The liquid drips in the drip chamber usually allow an estimate of the rate at which the liquid is administered.

Illustrative example of subject matter classified in this place:

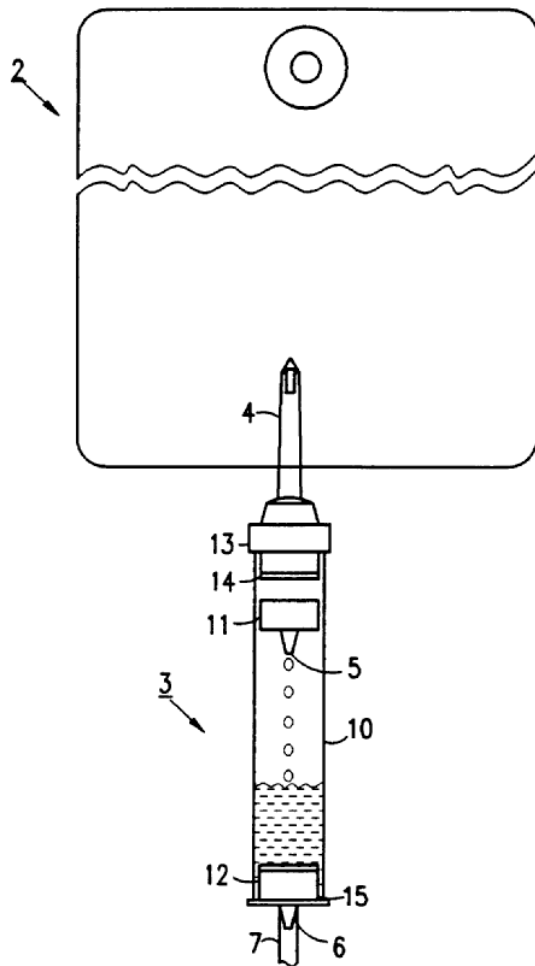

DATE: AUGUST 1, 2026

PROJECT RP11946

References

Limiting references

This place does not cover:

Drip counters	A61M 5/1689
Devices using low-level float-valve to cut off media flow from reservoir	A61M 5/40

Informative references

Attention is drawn to the following places, which might be of interest for search:

Needle sets	A61M 5/162
-------------	----------------------------

A61M 5/1412

Definition statement

This place covers:

Infusion burettes similar in shape and function to a drip chamber, but are specially designed to administer a measured volume. They usually comprise a scale and additional flow control means, such as a drip control or a valve.

Illustrative example of subject matter classified in this place:

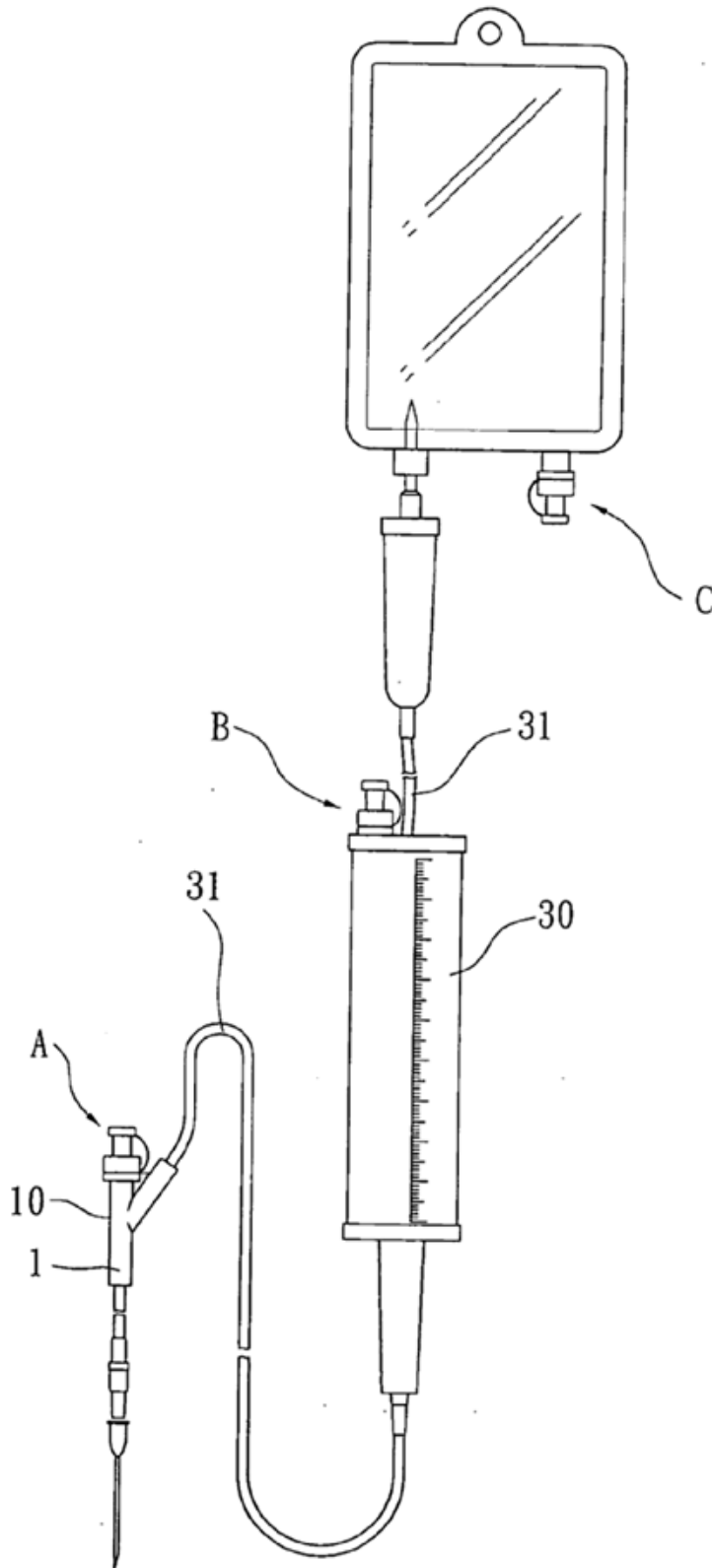

DATE: AUGUST 1, 2026

PROJECT RP11946

The Figure illustrates a burette (30) provided with a scale to allow the user to determine the administered volume.

References

Limiting references

This place does not cover:

Burettes; Pipettes	B01L 3/02
--------------------	---------------------------

A61M 5/1413

Definition statement

This place covers:

Devices comprising sub-components or sub-units and providing dedicated features relating to its modular structure, such as being exchangeable or assembled in different combinations or configurations.

References

Informative references

Attention is drawn to the following places, which might be of interest for search:

Infusion devices with reusable and disposable component	A61M 2005/14268
---	---------------------------------

A61M 5/1414

Definition statement

This place covers:

Gravity-driven infusion arrangements comprising, for example, infusion bags or similar hung-up containers.

DATE: AUGUST 1, 2026

PROJECT RP11946

A61M 5/1415

Definition statement

This place covers:

Means to hang any kind of gravity-driven infusion source at a certain height required for the infusion.

Other means to provide infusion accessories, such as tubes, valves or flow controllers.

References

Informative references

Attention is drawn to the following places, which might be of interest for search:

Holders or handles for hanging up infusion containers	A61M 5/1417
Clips, separators or the like for supporting tubes or leads	A61M 5/1418

A61M 2005/1416

Definition statement

This place covers:

Any support placed or attached to the body of the patient.

A61M 5/1417

Definition statement

This place covers:

The actual device supporting the infusion bag or container.

Illustrative example of subject matter classified in this place:

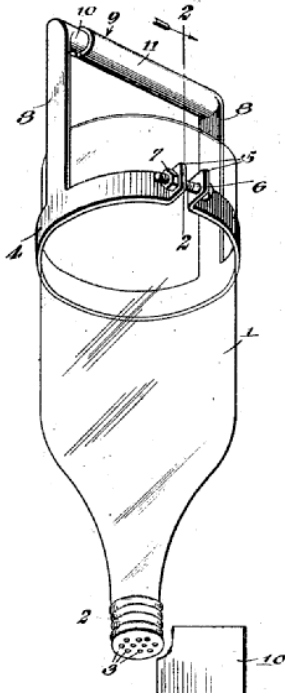

A61M 5/1418

Definition statement

This place covers:

Means for attaching or arranging one or several tubes to each other or to other devices.

Illustrative example of subject matter classified in this place:

a.

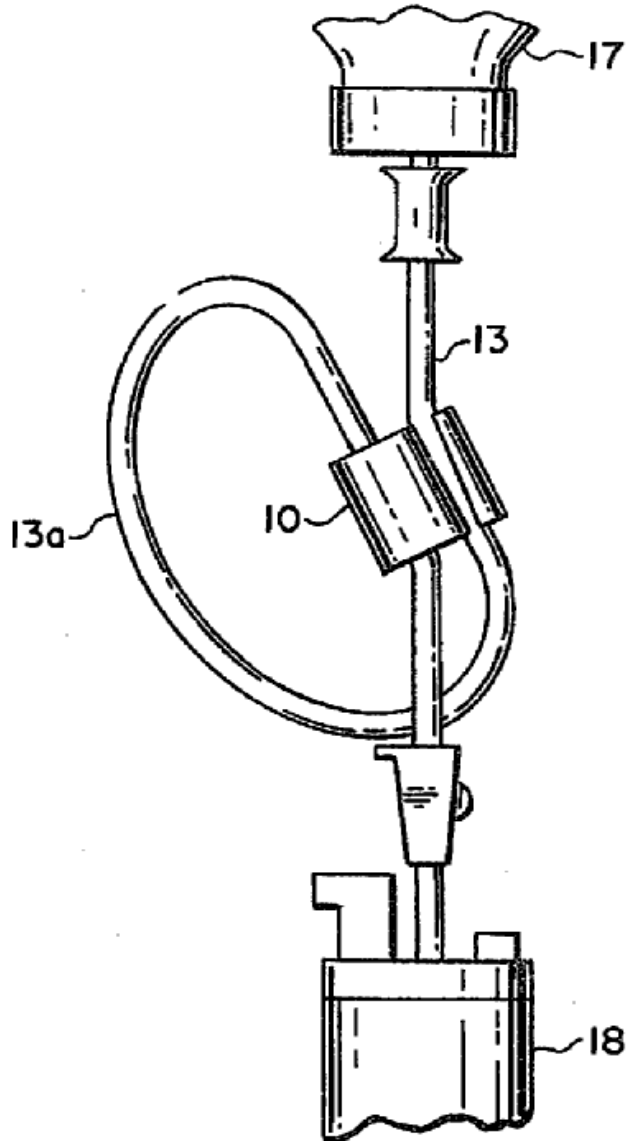

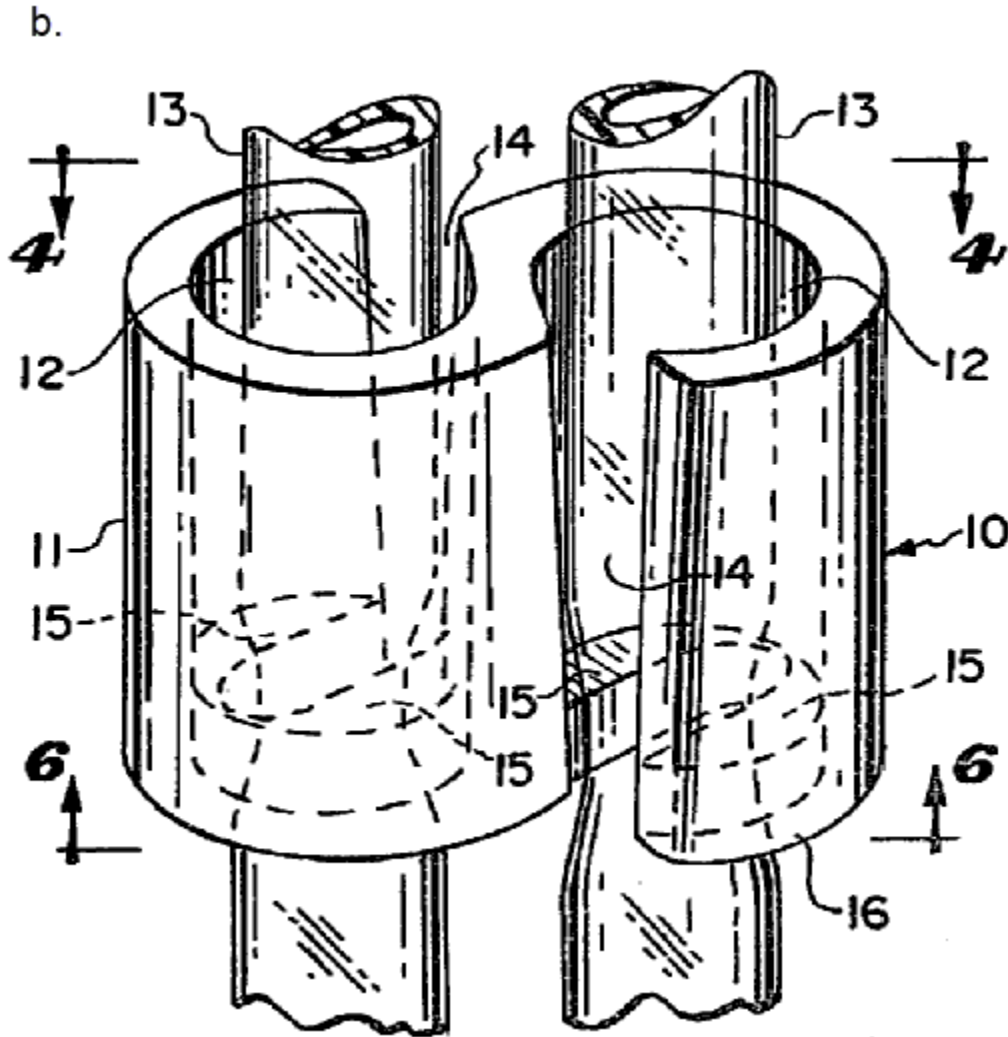

References

Informative references

Attention is drawn to the following places, which might be of interest for search:

Holding devices having a clip or clamp system	A61M 2025/024
---	-------------------------------

A61M 5/142

Definition statement

This place covers:

Infusion devices that generate a force or pressure on the infusion fluid (such as pumps).

A61M 2005/14204

Definition statement

This place covers:

The force or pressure for infusion is generated by an electrochemical reaction.

Illustrative example of subject matter classified in this place:

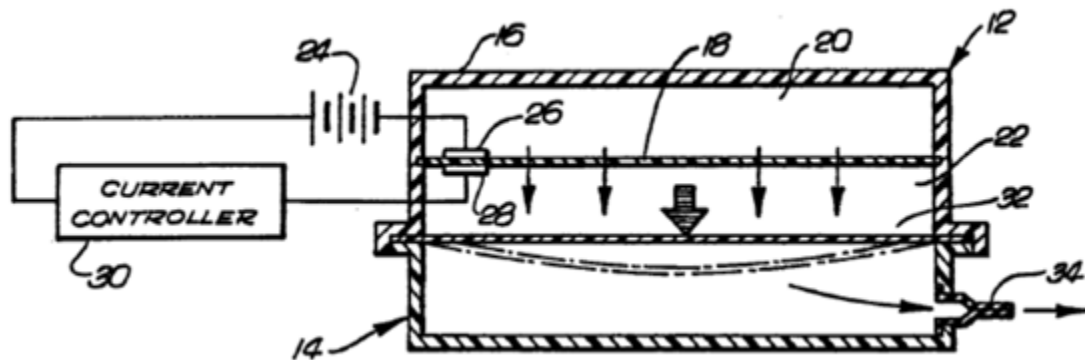

The Figure illustrates an electro-osmotic pumping by means of an (additional) drive fluid (20) acting via membrane (32) on the infusion fluid.

A61M 2005/14208

Definition statement

This place covers:

Particular aspects of infusion devices that are provided by software implemented features.

DATE: AUGUST 1, 2026

PROJECT RP11946

Relationship with other classification places

Attention is drawn to the group [G16H 20/17](#) for therapies or health-improving plans delivered via infusion or injection where classification should also be considered.

A61M 5/14212

Definition statement

This place covers:

Pumps that aspirate (draw) a fluid into a pump chamber and expel it in contrast to pumps solely expelling a fluid from a reservoir, such as a syringe pump.

A61M 5/14216

Definition statement

This place covers:

Pumps comprising a reciprocating piston not only moving in one direction.

Illustrative example of subject matter classified in this place:

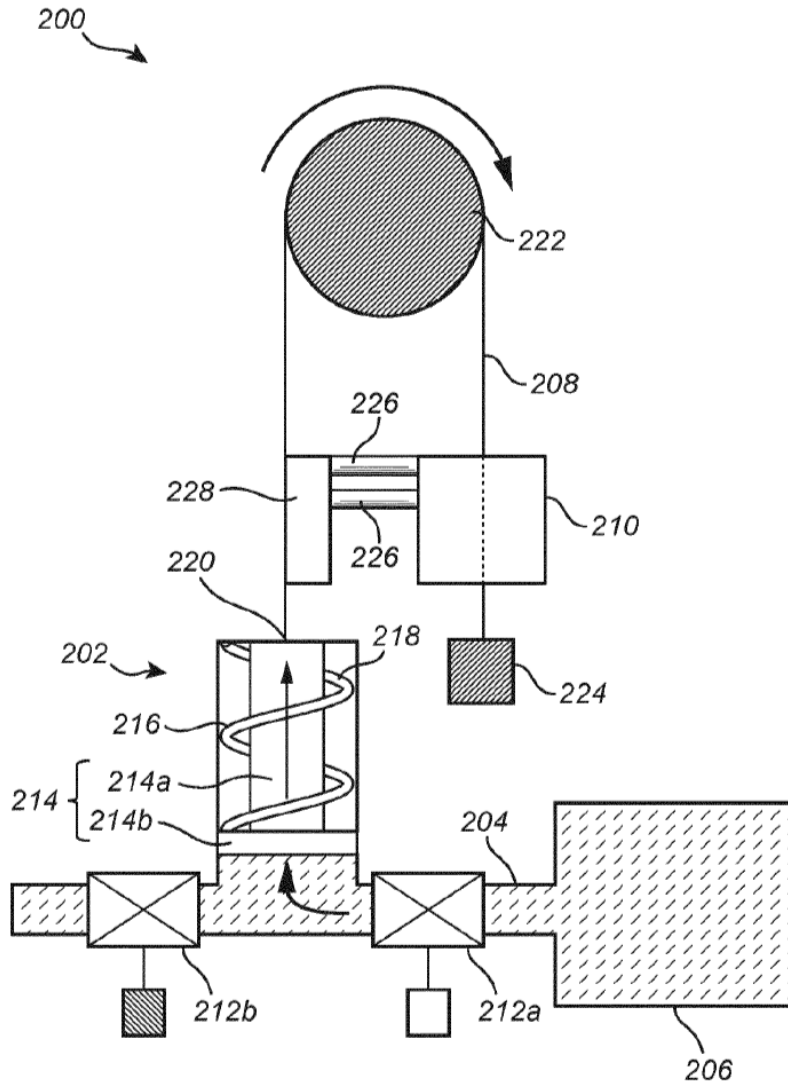

The Figure illustrates a pump comprising piston (214b) moving "up and down" to produce a unidirectional fluid flow via valves (212a, 212b).

A61M 5/1422

Definition statement

This place covers:

Pumps in which the infusion fluid is pumped alternately on both sides of the piston.

Multiple pistons are provided in the pump.

Illustrative example of subject matter classified in this place:

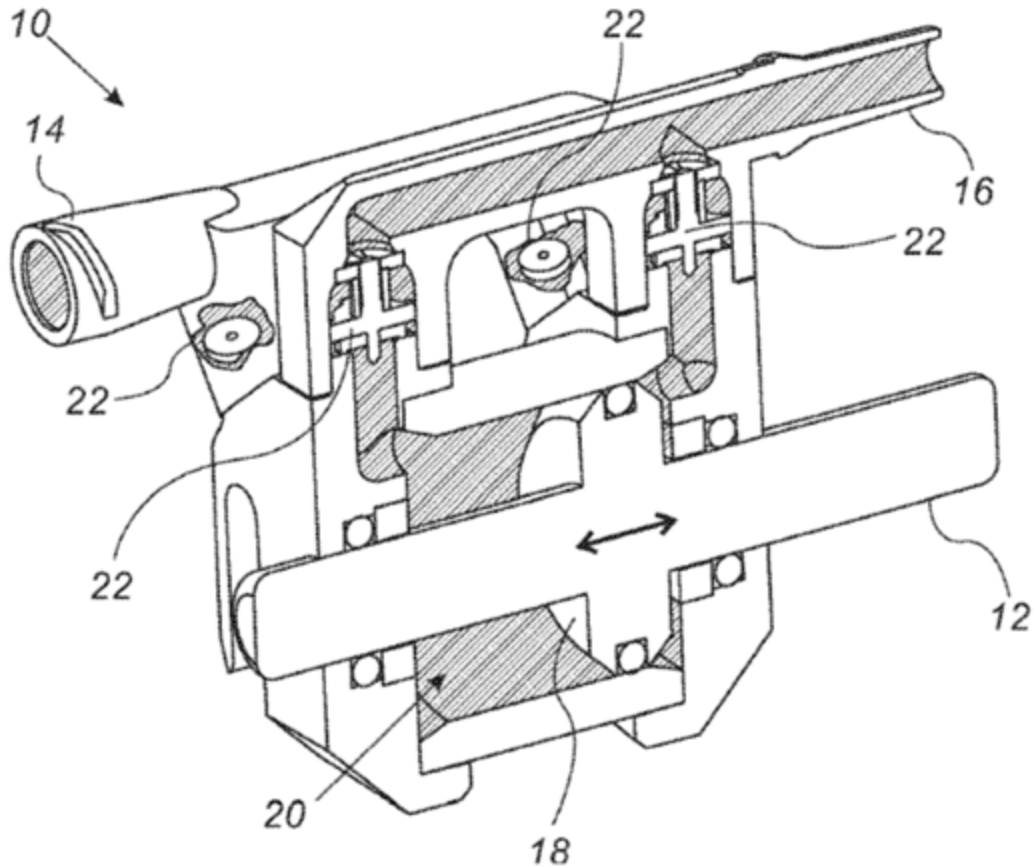

The Figure illustrates a piston (12) which displaces fluid when moved in the directions indicated by the arrow.

A61M 5/14224

Definition statement

This place covers:

The pump pressurising or moving the fluid through use of a flexible diaphragm (membrane).

Illustrative example of subject matter classified in this place:

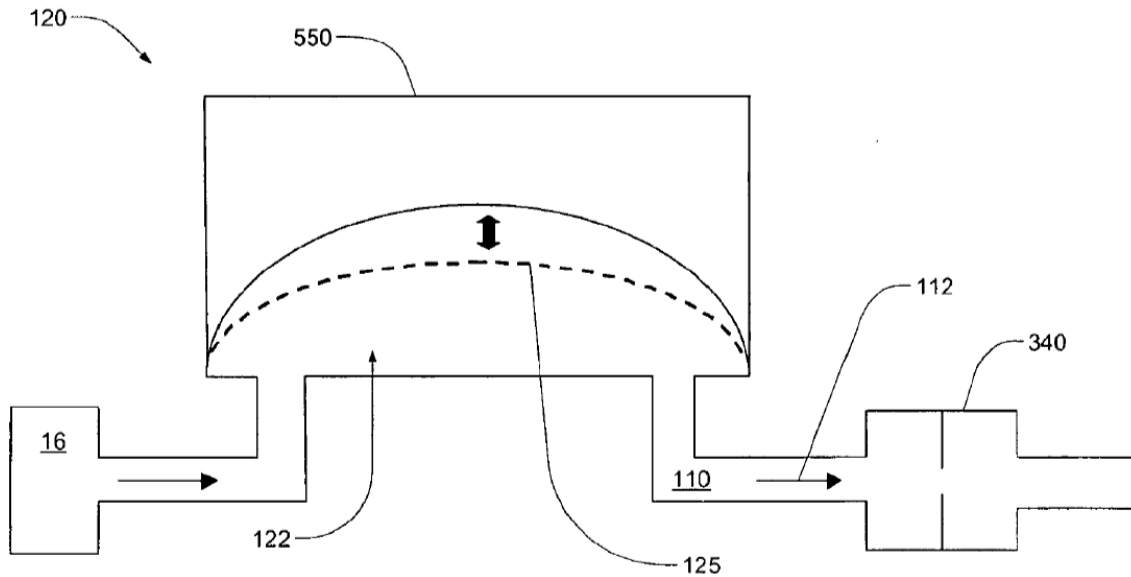

The Figure illustrates a force being generated in chamber 550, which acts on the infusion fluid (122) via diaphragm (125).

A61M 5/14236

Definition statement

This place covers:

Pumps in which the fluid moving force is applied by a rotation, usually by means of a rotating element within the fluid path.

Illustrative example of subject matter classified in this place:

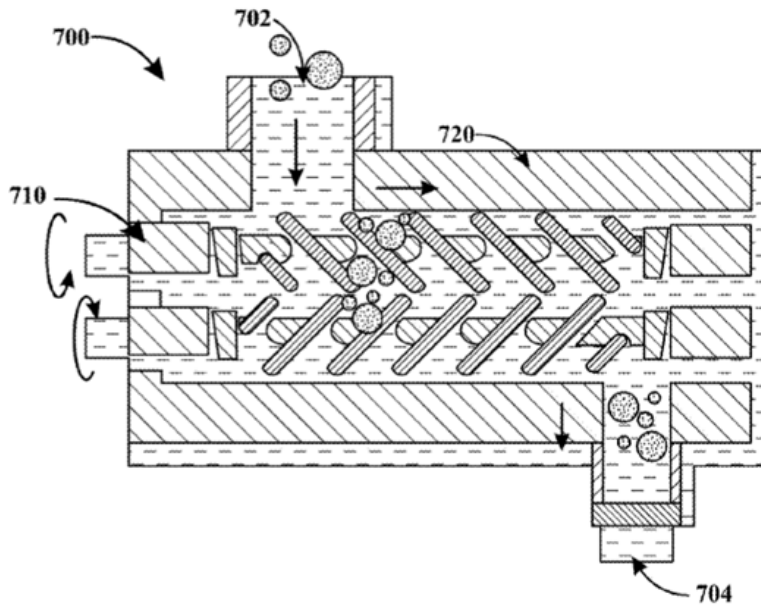

A61M 5/1424

Definition statement

This place covers:

Infusion devices in which the fluid driving force is generated by a user.

Also, for manual pumping which only relates to a bolus dose mechanism.

Illustrative example of subject matter classified in this place:

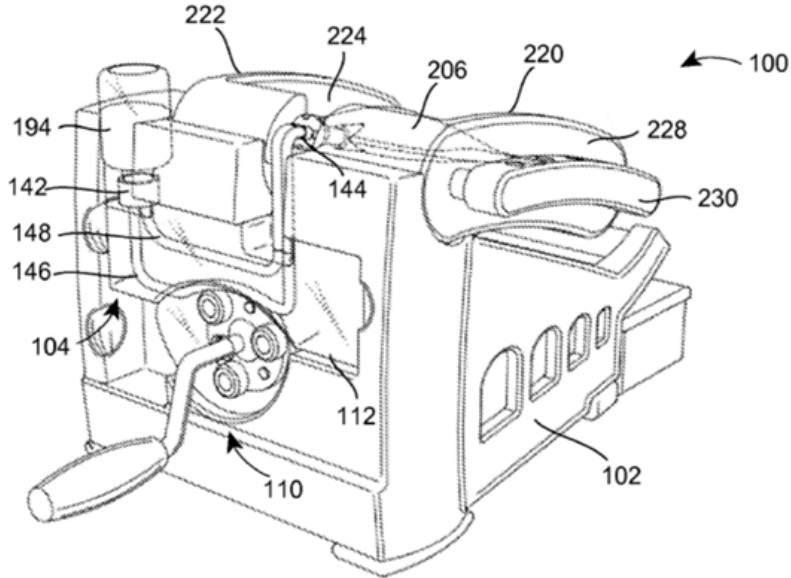

The Figure illustrates a roller pump (100) equipped with a hand crank (110).

A61M 5/14244

Definition statement

This place covers:

Infusion devices intended to be carried by the patient on the body, attached to clothes or carried in a pouch (or similar).

Illustrative example of subject matter classified in this place:

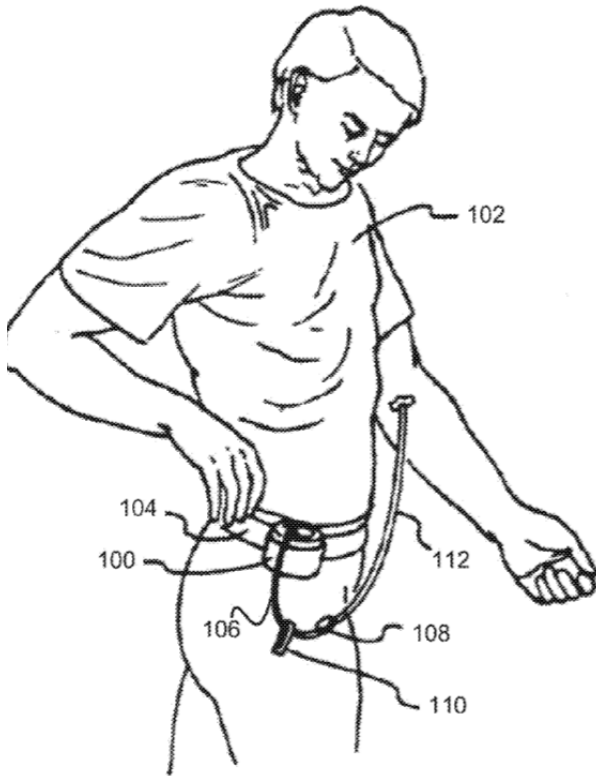

A61M 5/14248

Definition statement

This place covers:

Infusion devices adhered to the skin of the user and commonly referred to as patch pumps.

Illustrative example of subject matter classified in this place:

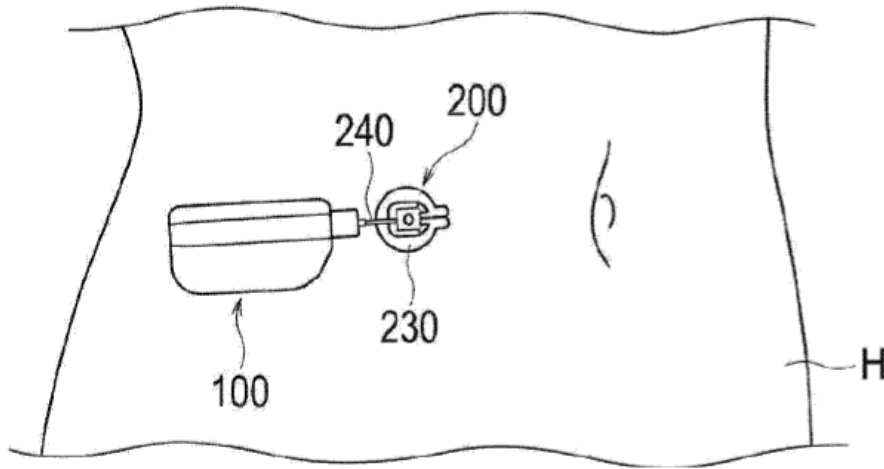

The Figure illustrates a pump (100) which is adhered to the skin of the user.

A61M 2005/14252

Definition statement

This place covers:

Patch pumps comprising a mechanism for inserting a needle or cannula.

Illustrative example of subject matter classified in this place:

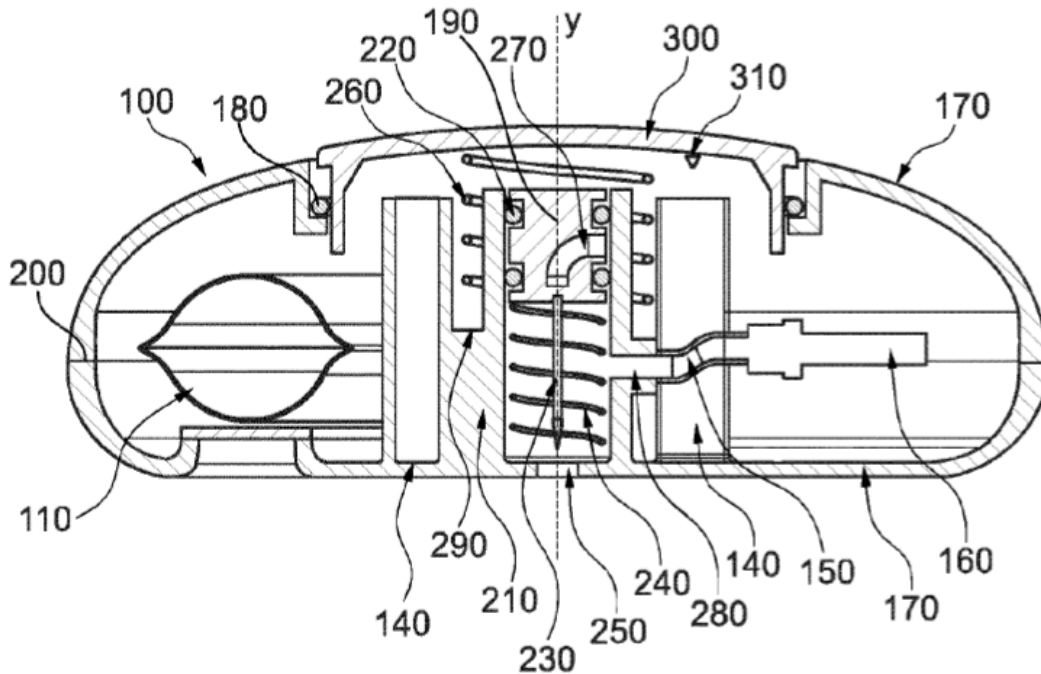

The Figure illustrates a pump provided with a button (300) which when pressed actuates a mechanism that inserts needle (230) into the skin of the patient.

Special rules of classification

If the needle is extracted or enclosed after use, classification should also be made in group [A61M 2005/1426](#).

A61M 2005/1426

Definition statement

This place covers:

Patch pumps in which the needle is enclosed after use. Usually, the needle will be extracted from a patient so that it moves back into the delivery device.

Illustrative example of subject matter classified in this place:

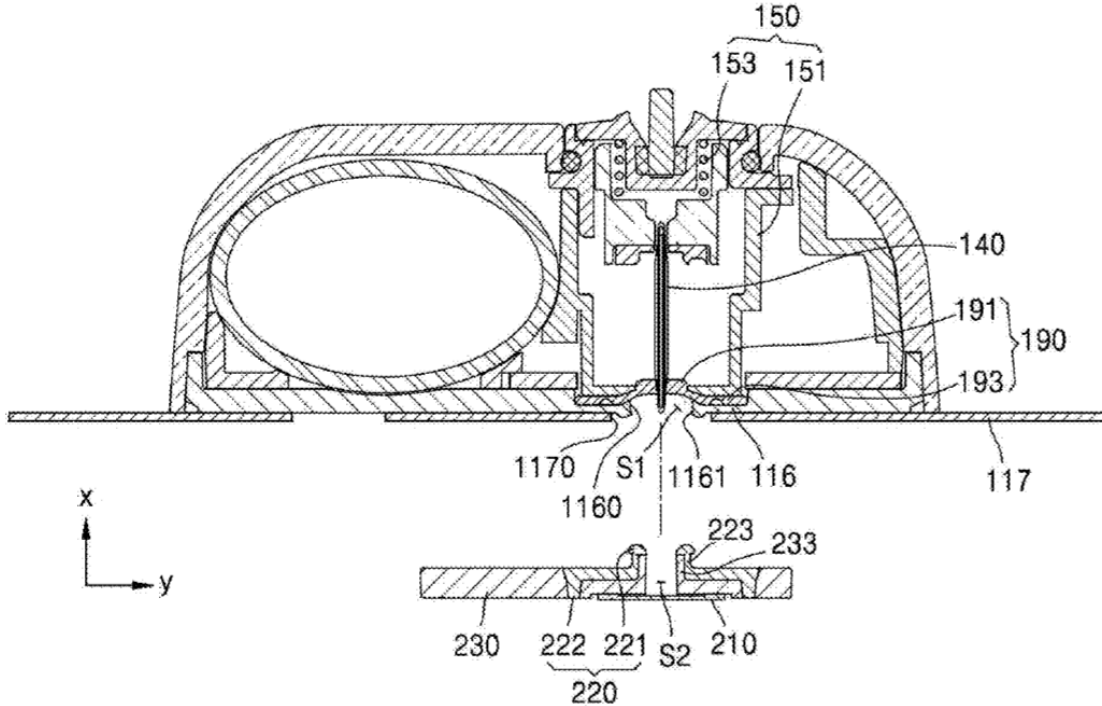

The Figure illustrates needle (140) which is retracted after use and is additionally covered by cap (230).

A61M 2005/14264

Definition statement

This place covers:

Wearable pumps with means to compensate for external influences.

Examples of external influences are atmospheric pressure variations (on the reservoir) or change in time when a user moves between different time zones.

A61M 2005/14268

Definition statement

This place covers:

A wearable pump comprising sub-units (such as a reservoir unit and a pump unit). Usually, the units that are in contact with the medical fluid are disposed after use, whereas units comprising drive and electronic means can be re-used.

Illustrative example of subject matter classified in this place:

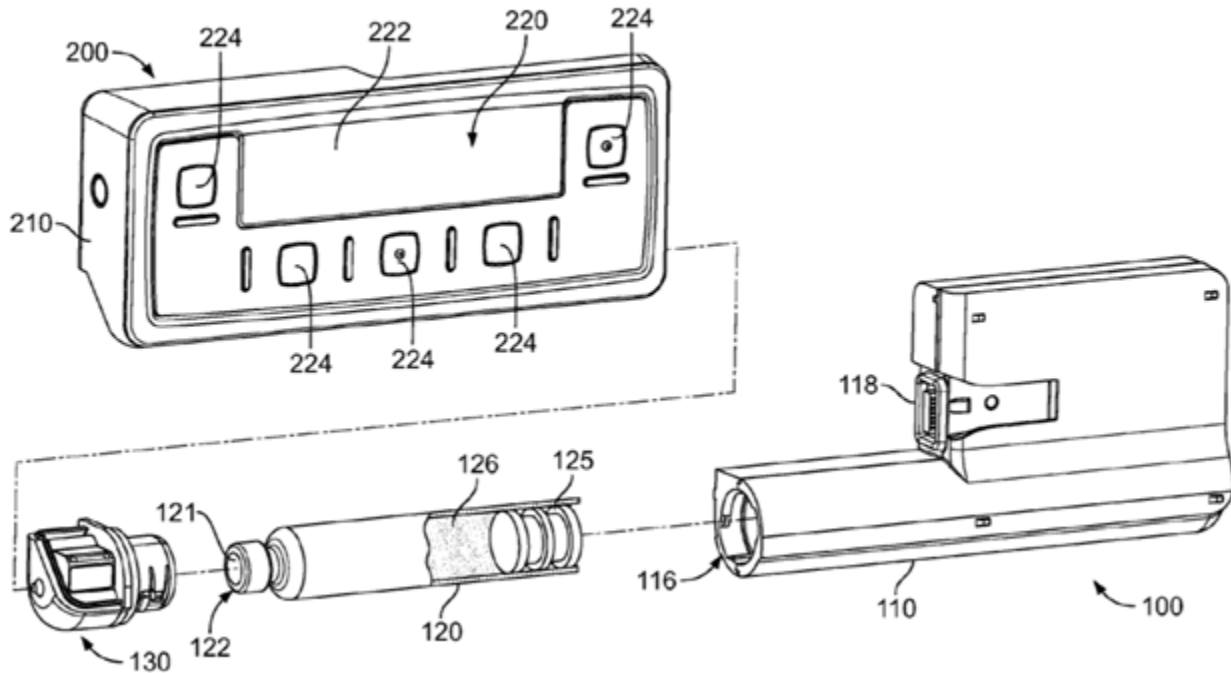

A61M 2005/14272

Definition statement

This place covers:

Pump devices worn by a user on or close to the skin, and which (often automatically) provide a medical fluid either in an emergency situation or upon user actuation.

Illustrative example of subject matter classified in this place:

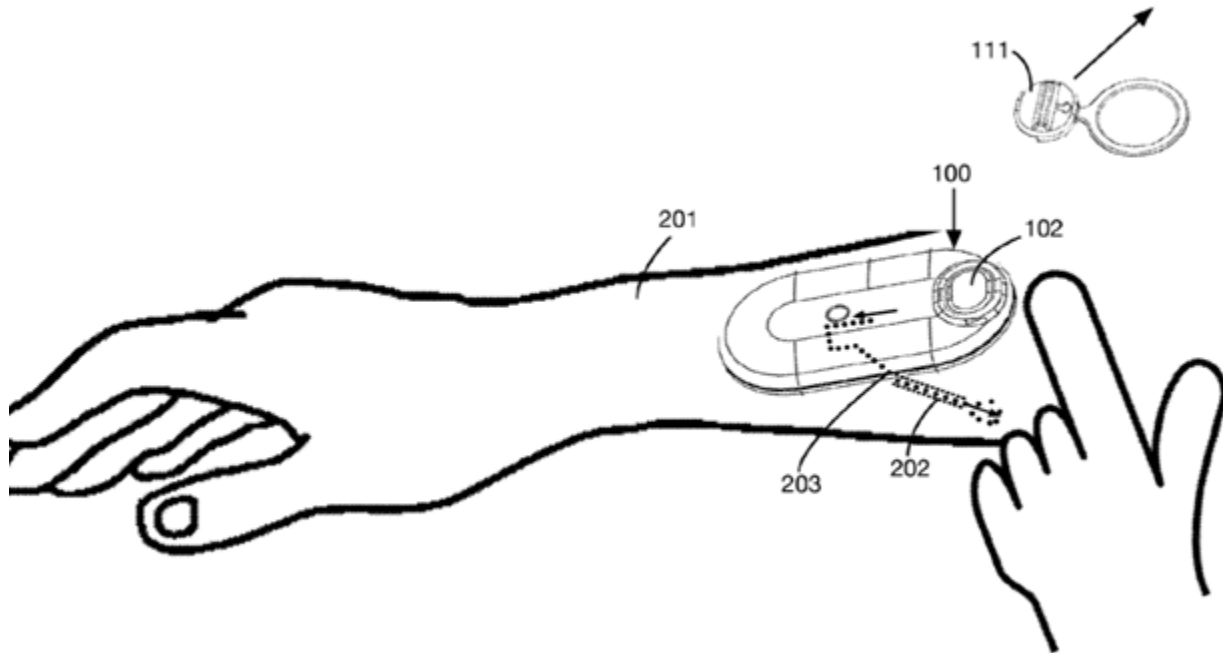

The Figure illustrates a user self-administering an infusion or injection upon pulling tab (111).

A61M 5/14276

Definition statement

This place covers:

Infusion devices which will be implanted in the body of a user.

Relationship with other classification places

For implanted devices in which a drug is administered by other means (such as dilution) or for pills that are swallowed, group [A61M 31/002](#) should be considered.

Special rules of classification

Only implantable drug expelling devices that administer a fluid by means of a pump mechanism (as defined in the [A61M 5/14](#) range) should be classified here.

DATE: AUGUST 1, 2026

PROJECT RP11946

Pump devices classified here often also qualify as injection devices. Therefore, respective injection groups (for example group [A61M 5/20](#)) should be given where appropriate.

A61M 5/1428

Definition statement

This place covers:

Implanted infusion devices in which the pump force is generated by a user.

Illustrative example of subject matter classified in this place:

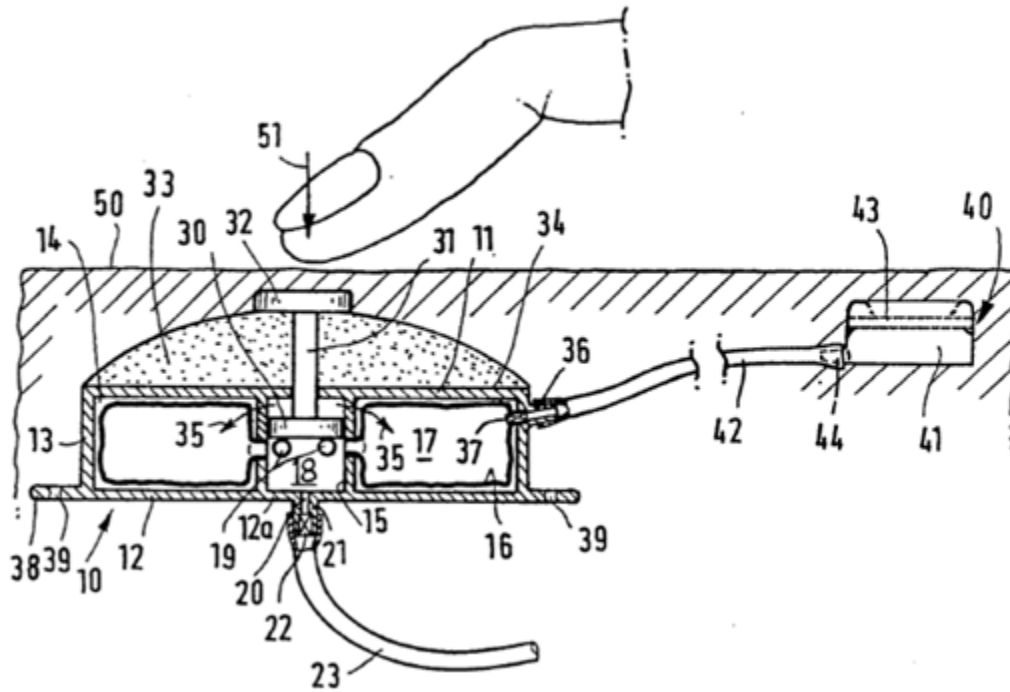

The Figure illustrates a user pressing with a finger (51) on the skin close to the implanted device thereby generating a pumping movement of the piston-like element (31).

A61M 2005/14284

Definition statement

This place covers:

Implantable pumps with means to move and extend an infusion needle from the device.

Illustrative example of subject matter classified in this place:

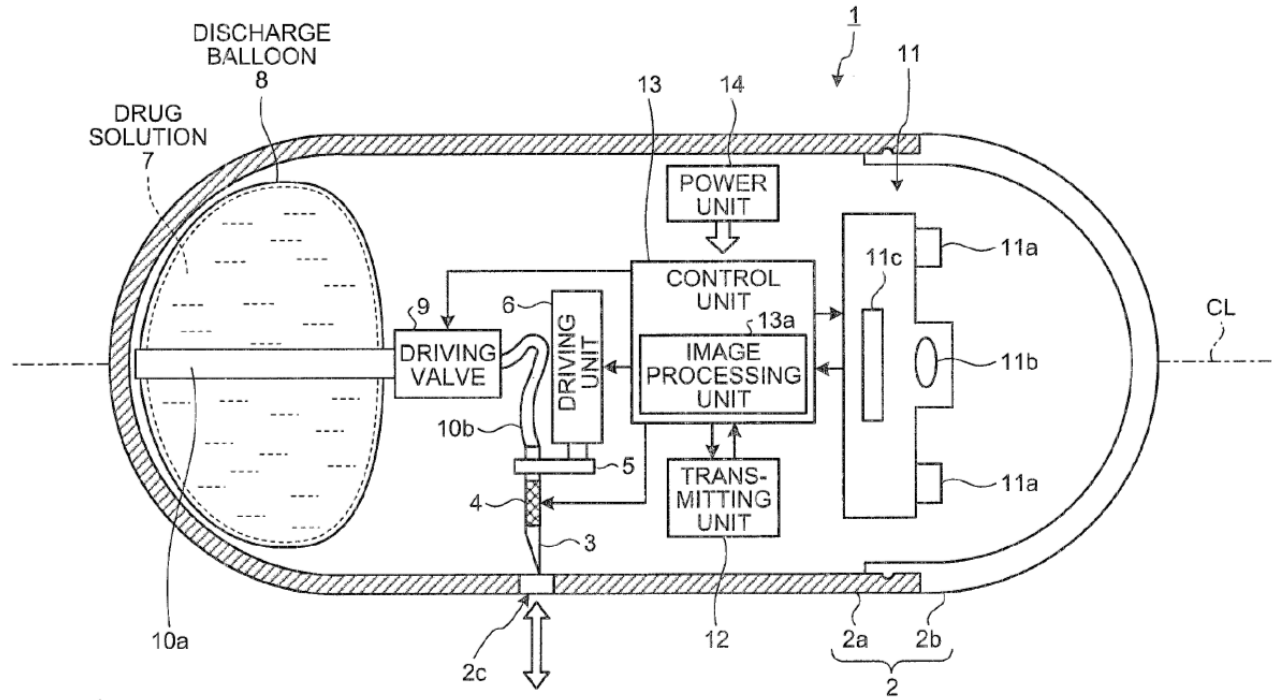

A61M 2005/14292

Definition statement

This place covers:

Information and computer technology with the purpose of determining or planning optimal infusion parameters (such as time or dose) or the logistical distribution of medical infusion fluids.

DATE: AUGUST 1, 2026

PROJECT RP11946

A61M 2005/14296

Definition statement

This place covers:

Aspects relating to or taking into account the pharmacological effect of the administered fluid (such as by providing an algorithm that accounts for individual drug sensitivity).

A61M 5/145

Definition statement

This place covers:

Infusion devices in which the reservoir is subject to a permanent positive pressure.

Relationship with other classification places

If the expelling force to the fluid is provided by a piston, group [A61M 5/1452](#) and its subgroups should be given.

Pumps with an aspiration and expulsion stroke are classified under group [A61M 5/14212](#).

A61M 2005/14506

Definition statement

This place covers:

Infusion devices in which the fluid expelling force is stored and provided by mechanical means, such as a spring.

Illustrative example of subject matter classified in this place:

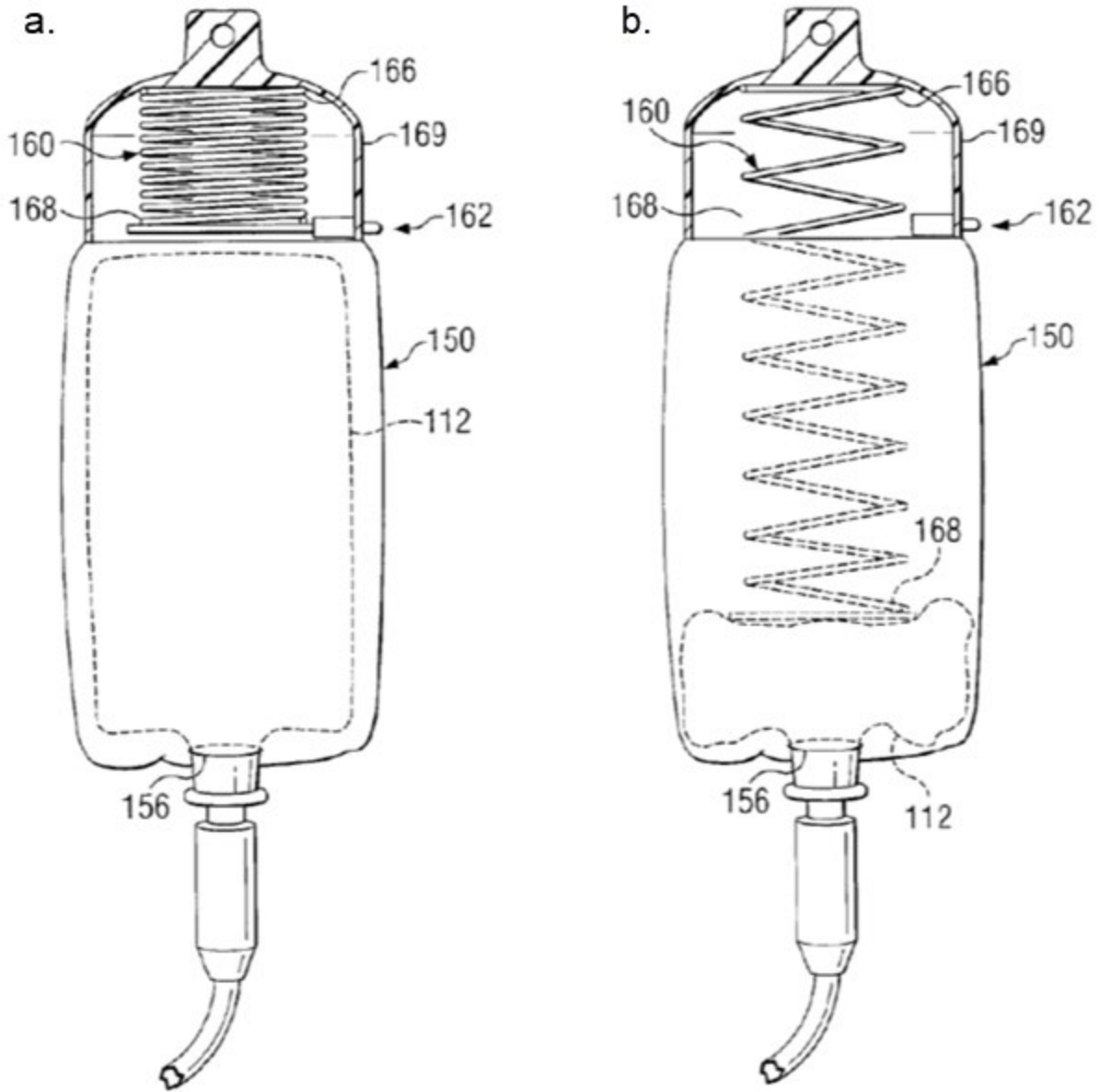

Relationship with other classification places

If the expelling force to the fluid is provided by a piston sealing and moving relative to the reservoir, group [A61M 5/1454](#) should be given instead.

CPC NOTICE OF CHANGES 1933

DATE: AUGUST 1, 2026

PROJECT RP11946

A61M 2005/14513

Definition statement

This place covers:

Infusion devices in which the fluid expelling force is conveyed (or generated) by an additional fluid.

Illustrative example of subject matter classified in this place:

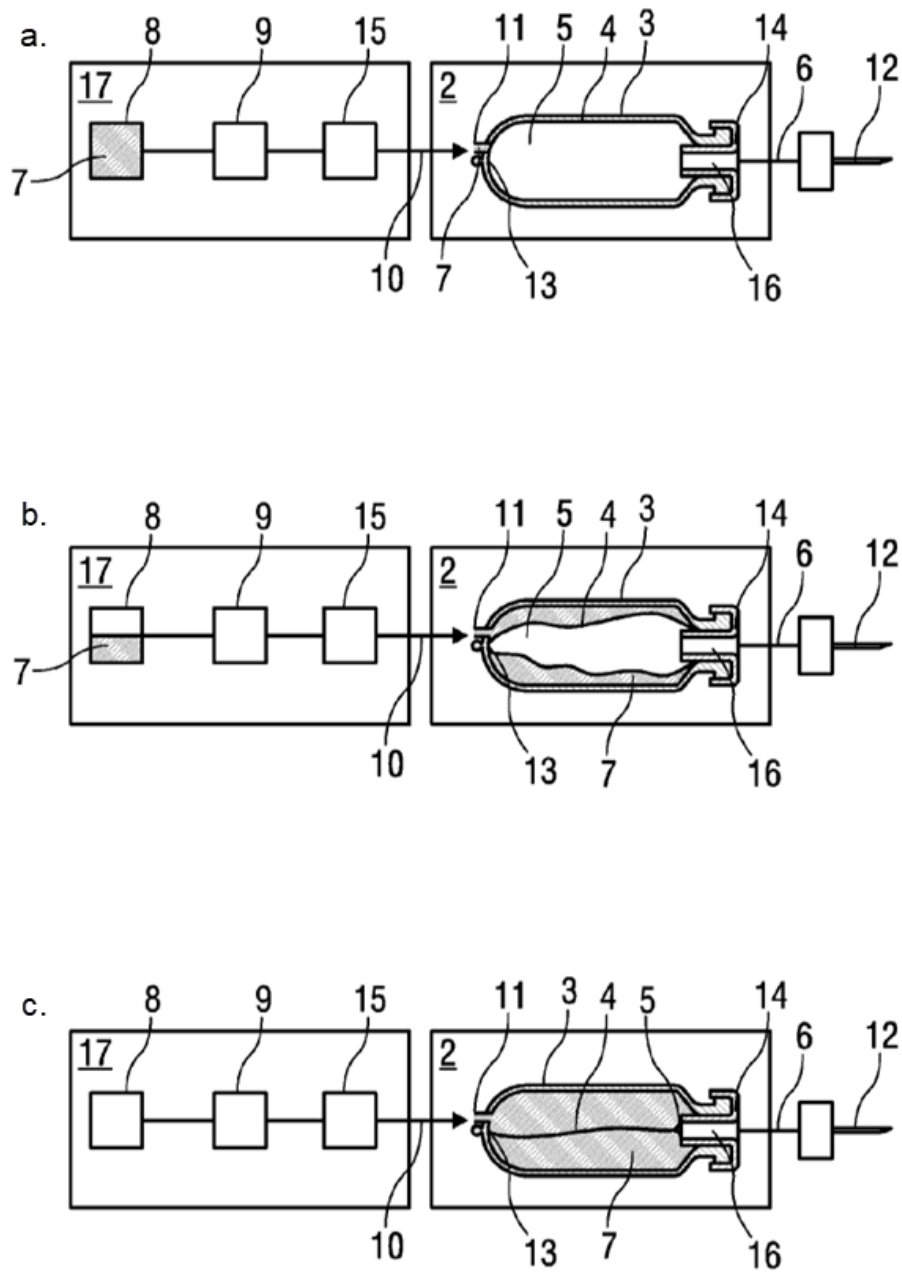

The Figure illustrates a fluid (5) being expelled from a flexible reservoir (4) via second fluid (7).

DATE: AUGUST 1, 2026

PROJECT RP11946

A61M 5/1452

Definition statement

This place covers:

Infusion devices in which the fluid pressurising or moving force is conveyed by a movable piston, which also seals the reservoir.

A61M 5/14526

Definition statement

This place covers:

Infusion devices in which the piston is pressurised or moved by an additional fluid.

Illustrative example of subject matter classified in this place:

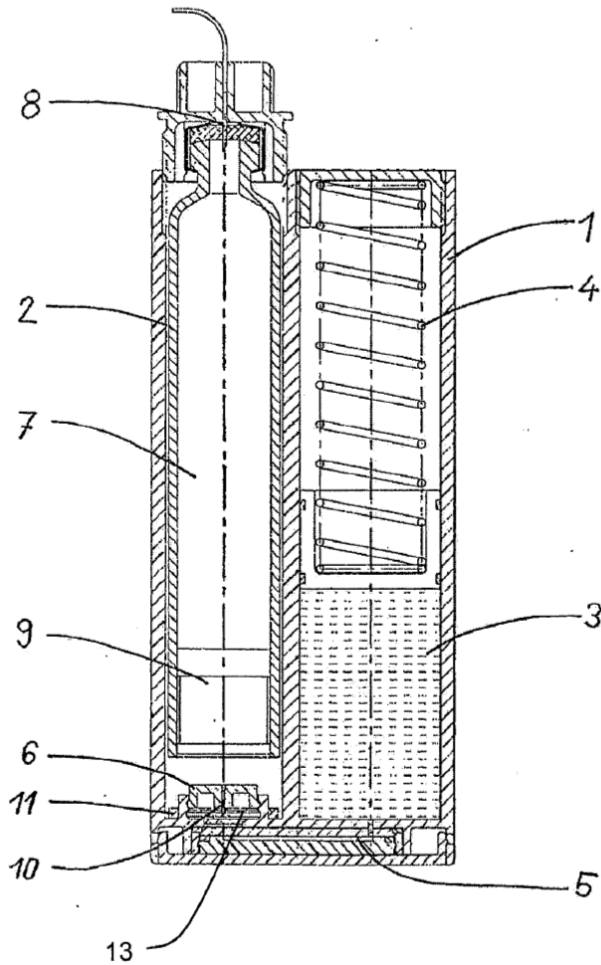

The Figure illustrates a secondary fluid (3) passing through flow constriction (5) in order to move piston (9) and expel a medicament fluid (7).

A61M 2005/14533

Definition statement

This place covers:

Rotary motion translated into linear piston movement by cam means.

Illustrative example of subject matter classified in this place:

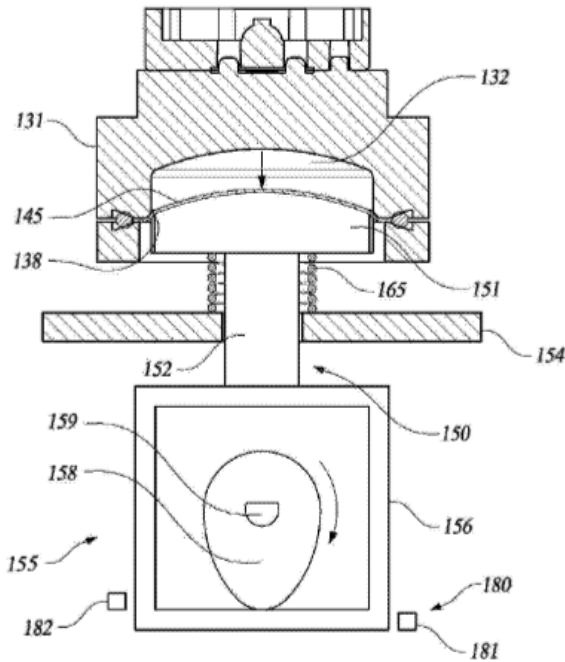

The Figure illustrates a cam (158) which rotates and pressurises a fluid (132) via piston (151).

A61M 5/1454

Definition statement

This place covers:

Infusion devices in which a piston is pressurised or moved by a spring force.

A61M 5/14546

Definition statement

This place covers:

Infusion devices in which a syringe is attached on a front portion.

Illustrative example of subject matter classified in this place:

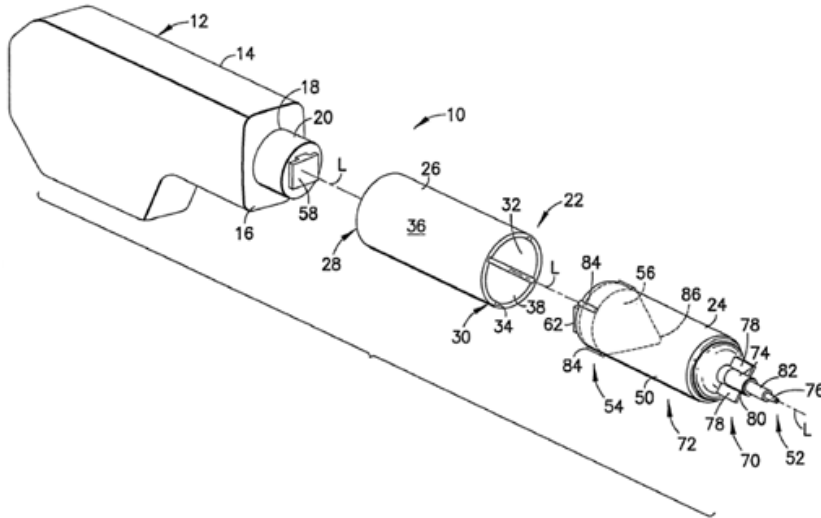

The Figure illustrates a high-pressure infusion device for contrast media.

A61M 2005/14553

Definition statement

This place covers:

High-pressure (front loading) injectors in which the syringe barrel is provided with a skirt (to cope with the elevated injection pressure).

Illustrative example of subject matter classified in this place:

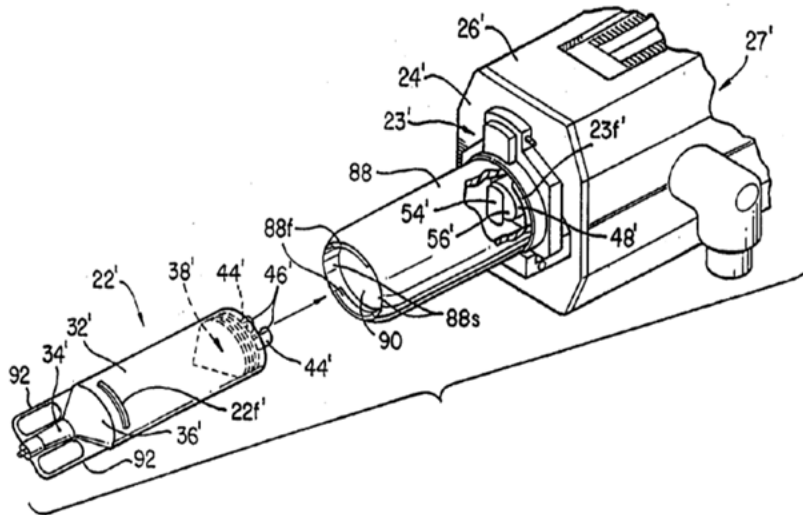

The Figure illustrates a pressure jacket (88) enclosing syringe (22').

A61M 5/1456

Definition statement

This place covers:

Conventional syringe pumps.

Illustrative example of subject matter classified in this place:

DATE: AUGUST 1, 2026

PROJECT RP11946

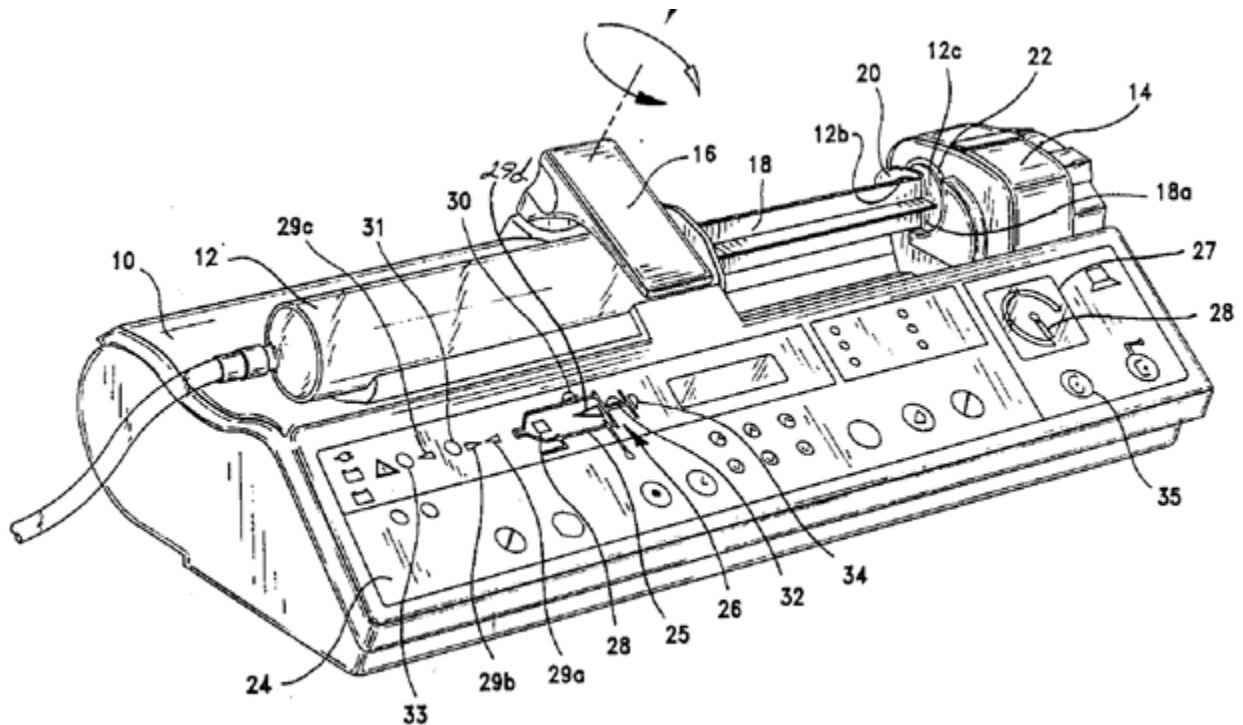

The Figure illustrates a syringe (12) comprising a plunger (18) mounted on a syringe pump which is used to set the infusion administration parameters and control the movement of the plunger actuation head (14).

A61M 5/14566

Definition statement

This place covers:

Pump devices with an integrated piston rod, the pump receiving a replaceable reservoir comprising a movable piston.

Illustrative example of subject matter classified in this place:

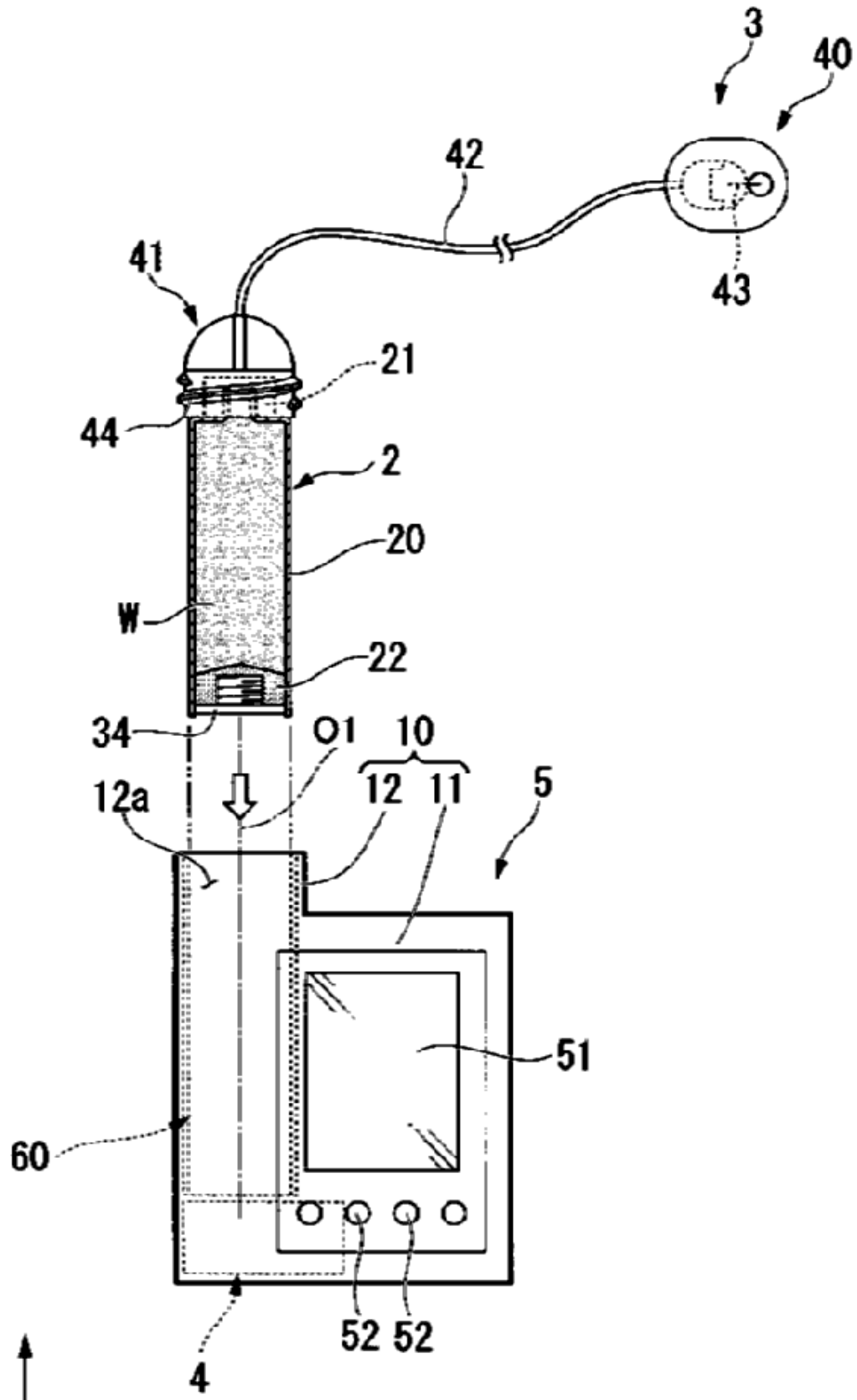

The Figure illustrates a pump comprising a plunger (not visible in the drawing), which moves the piston (22) to expel a medicament from vial (2).

A61M 2005/14573

Definition statement

This place covers:

Features of the connection between a replaceable reservoir and the pump unit, which usually allow for quick or improved connection.

Illustrative example of subject matter classified in this place:

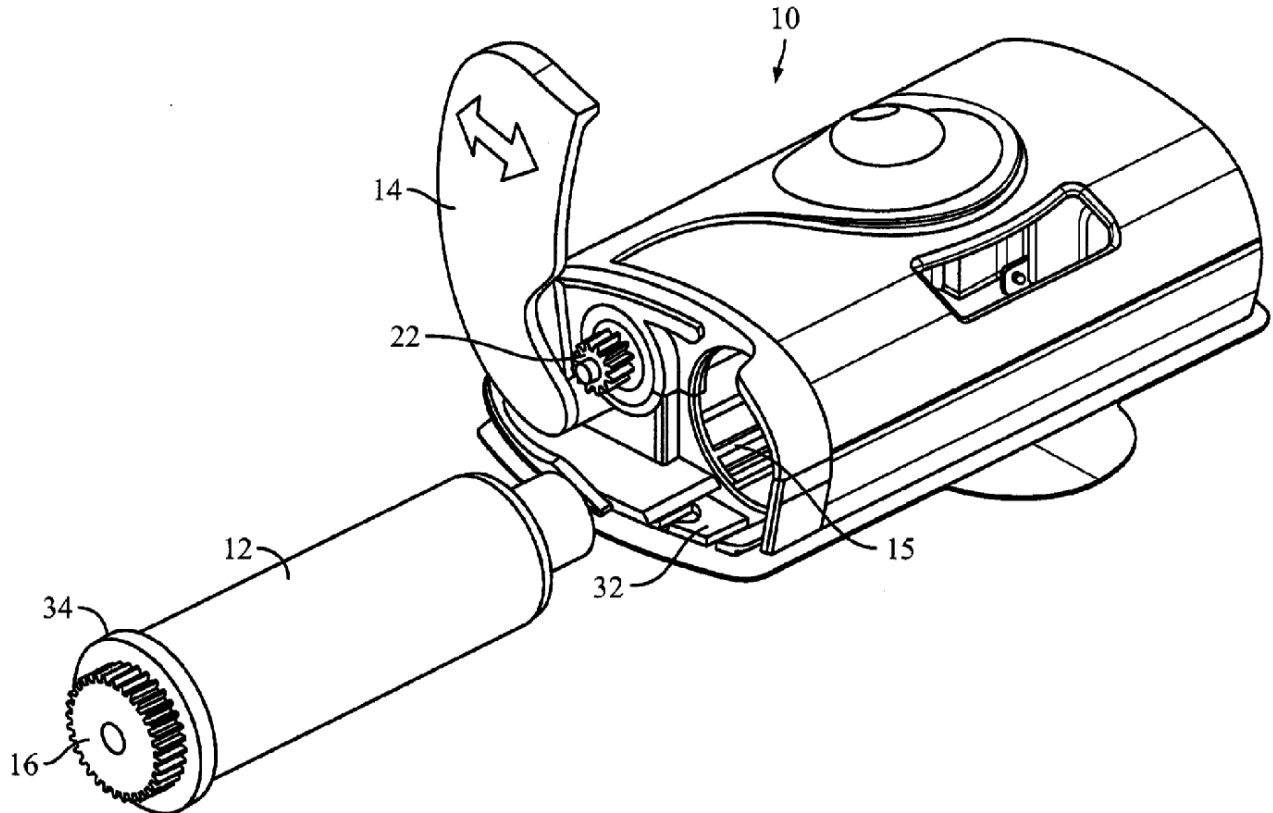

The Figure illustrates a gearing mechanism (16) on the proximal end of the vial (12) which allows for quick connection to the drive mechanism of the pump device (10).

A61M 5/1458

Definition statement

This place covers:

Means for retain the flange of the plunger (to prevent a siphoning movement) in which the plunger loses contact with a plunger driver.

Illustrative example of subject matter classified in this place:

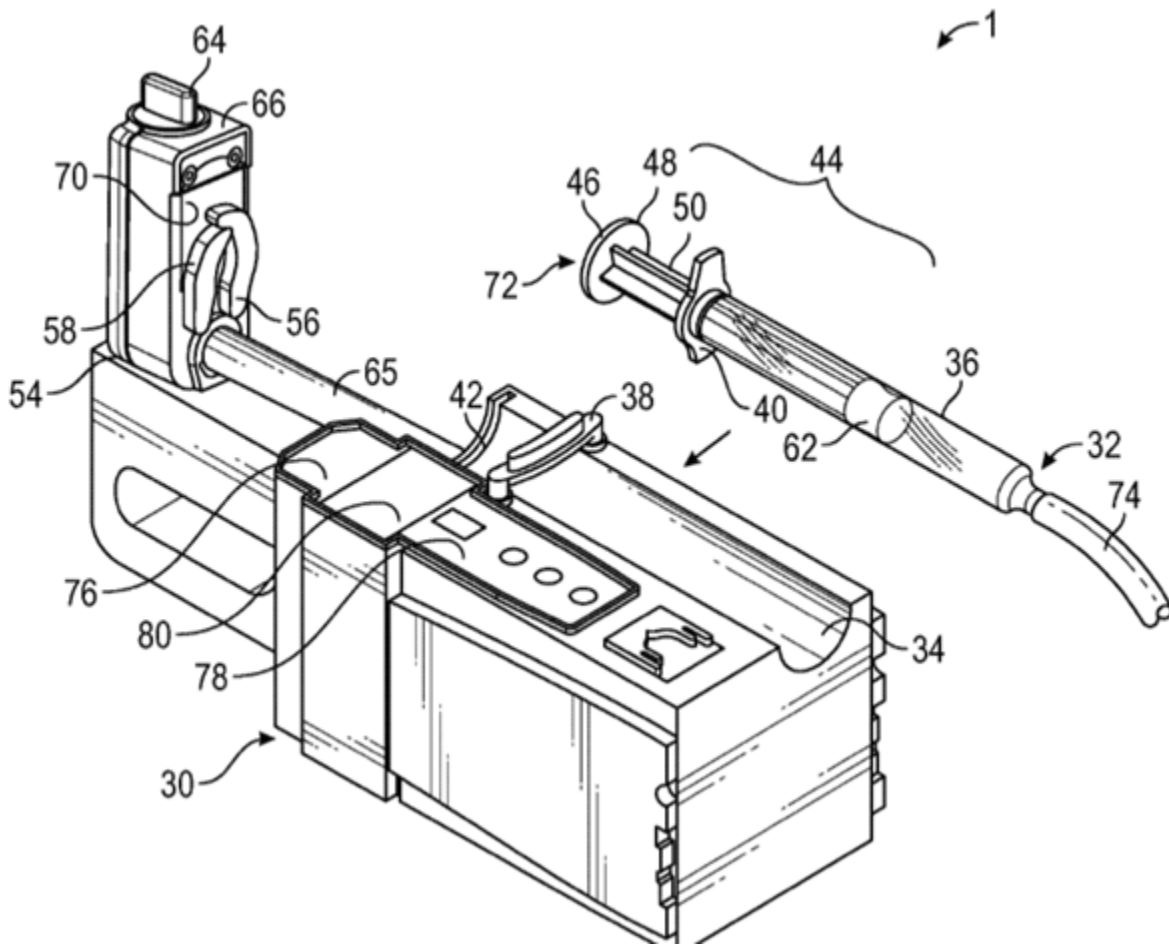

The Figure illustrates arms (56) for holding and retaining flange (48) in contact with surface (70).

DATE: AUGUST 1, 2026

PROJECT RP11946

A61M 5/14586

Definition statement

This place covers:

Pressurised reservoirs in which the pressurising force is conveyed through a flexible diaphragm. For example, a pump chamber pressurised by a flexible diaphragm that is acted upon by a driving piston. (The diaphragm is sometimes termed membrane).

Illustrative example of subject matter classified in this place:

a.

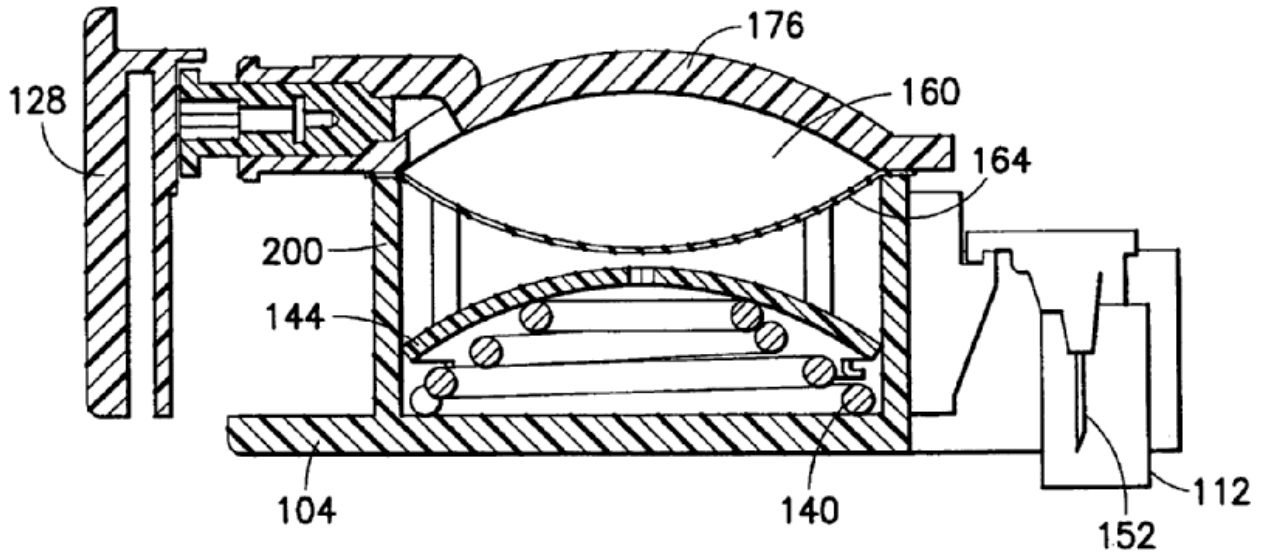

b.

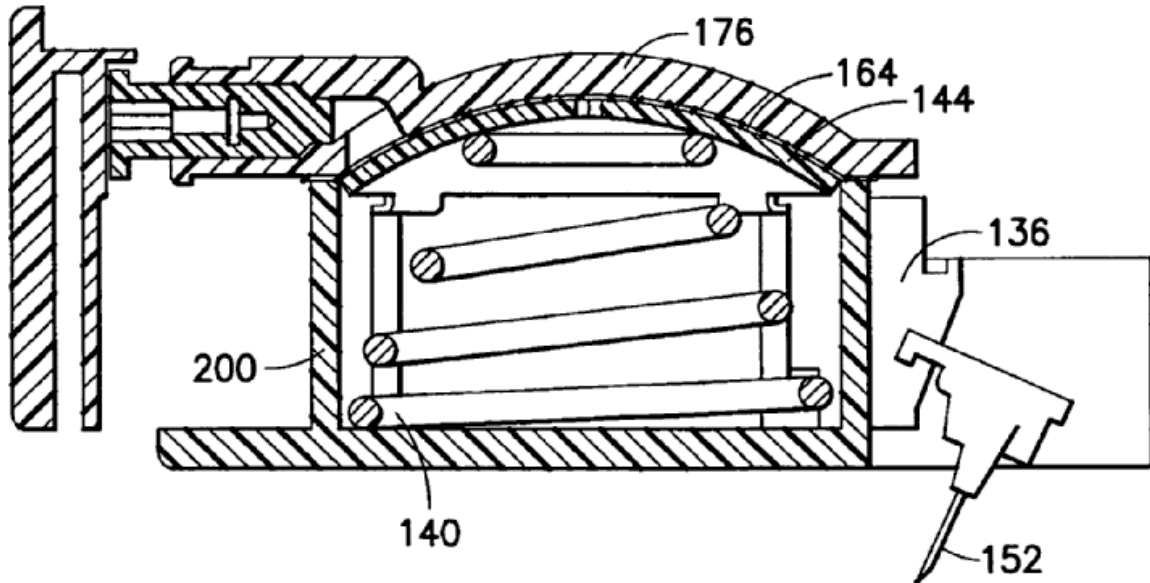

The Figure illustrates a reservoir (160) which is enclosed by flexible diaphragm (164).

Relationship with other classification places

If the entire pump chamber (reservoir) is made of flexible diaphragms (i.e. a bag type container), classification should only be in group [A61M 5/148](#), as this group is more specific.

A61M 5/14593

Definition statement

This place covers:

Illustrative example of subject matter classified in this place:

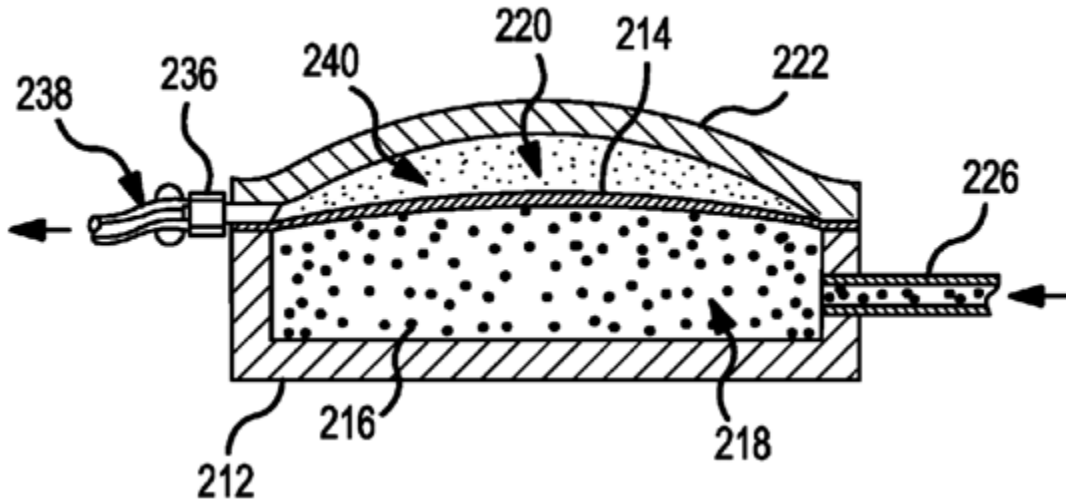

The Figure illustrates a medicament reservoir (240) where force is applied by a diaphragm (214) that is acted upon by another fluid (216). The diaphragm is sometimes referred to as a membrane.

A61M 5/148

Definition statement

This place covers:

The entire reservoir is formed by a flexible bag or bellows.

Illustrative example of subject matter classified in this place:

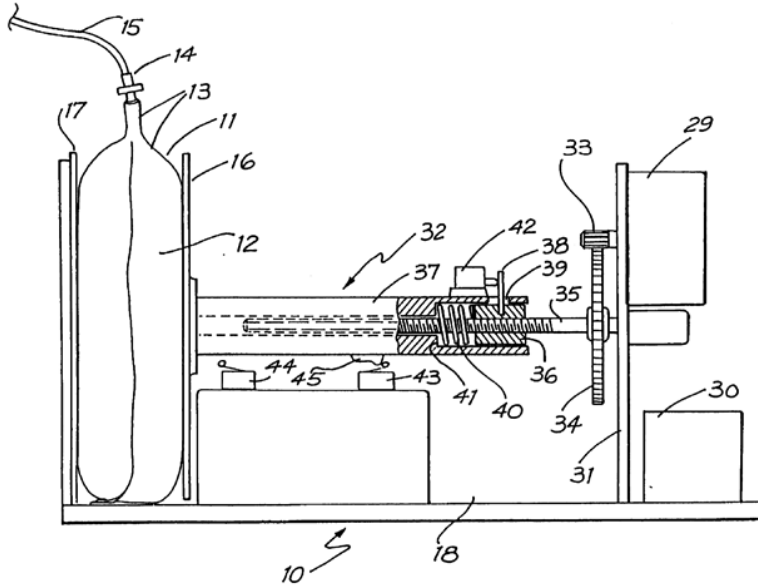

References

Limiting references

This place does not cover:

Reservoirs pressurised by gas (introduced in the reservoir)	A61M 5/155
---	----------------------------

A61M 5/1483

Definition statement

This place covers:

The reservoir is pressurised by a fluid acting externally on the reservoir.

Illustrative example of subject matter classified in this place:

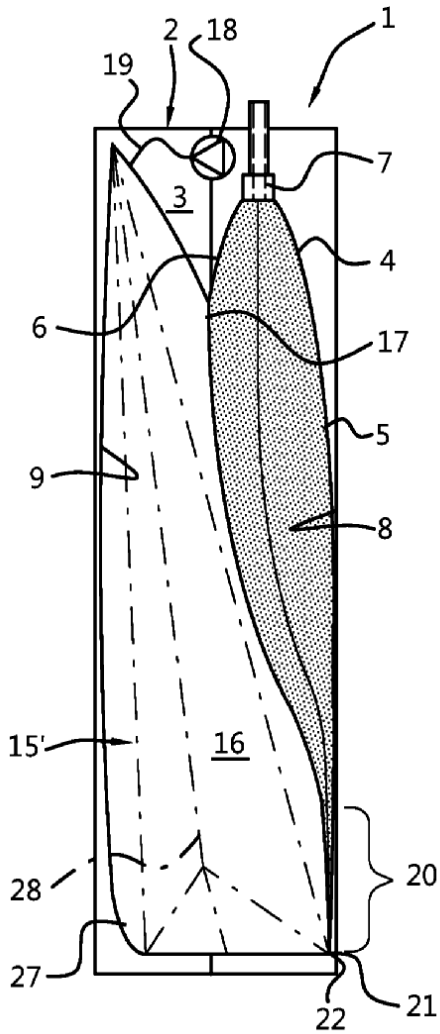

A61M 5/1486

Definition statement

This place covers:

The reservoir being pressurised and essentially enclosed by a fluid outside of the reservoir.

Illustrative example of subject matter classified in this place:

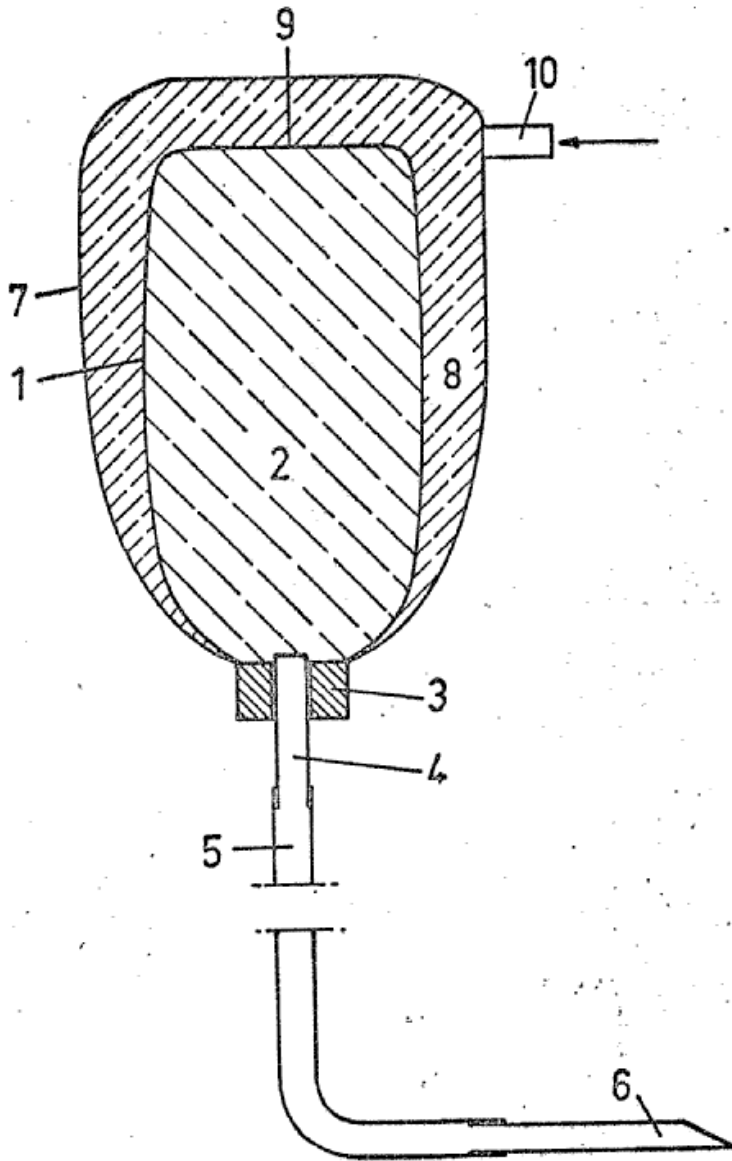

A61M 5/152

Definition statement

This place covers:

The reservoir content is pressurised by an elastic wall of the reservoir.

Illustrative example of subject matter classified in this place:

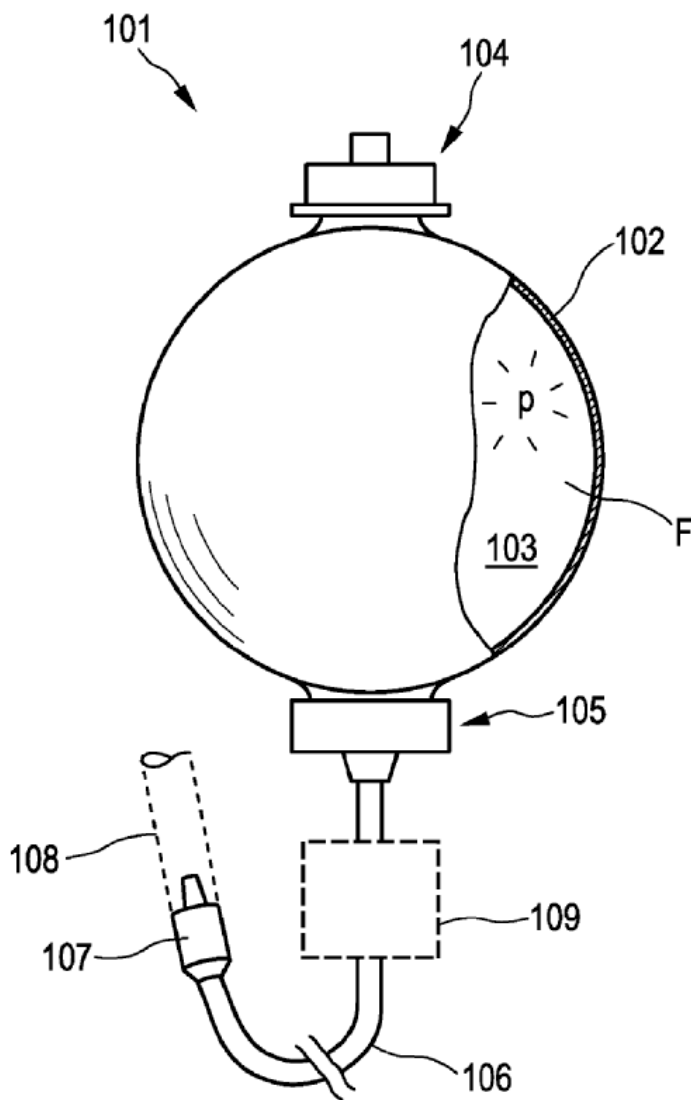

DATE: AUGUST 1, 2026

PROJECT RP11946

References

Informative references

Attention is drawn to the following places, which might be of interest for search:

Containers for dispensing fluent contents by means of a flexible bag or a deformable membrane or diaphragm	B65D 83/771
--	-----------------------------

A61M 5/155

Definition statement

This place covers:

The medicament fluid pressurised by gas introduced directly into the reservoir and acting directly on the medicament fluid.

Illustrative example of subject matter classified in this place:

DATE: AUGUST 1, 2026

PROJECT RP11946

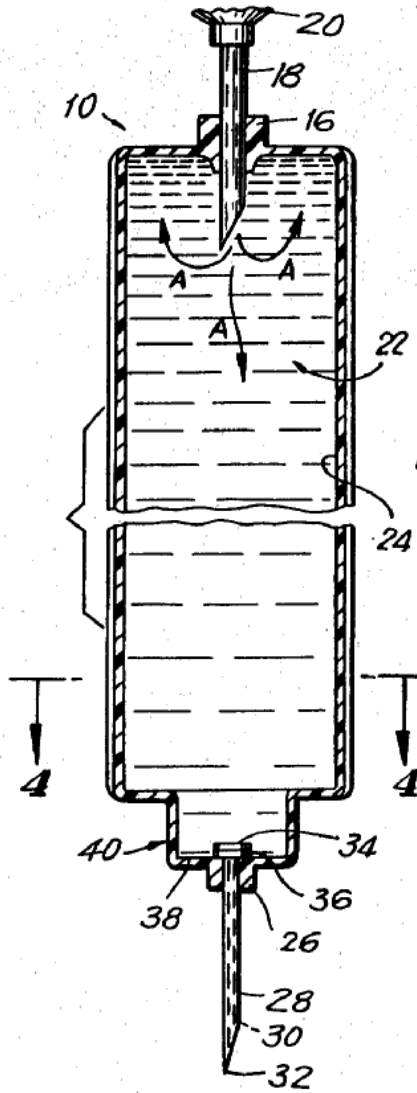

A61M 5/158

Definition statement

This place covers:

Body piercing needles and devices with body piercing needles, with infusion specific features. These needles are either part of or attachable to an infusion set (also called needle set). The needle usually stays in the body for a prolonged period (in contrast to an injection procedure, see also below).

DATE: AUGUST 1, 2026

PROJECT RP11946

This place also applies to infusion cannulas inserted by means of a (rigid) body piercing needle and infusion catheters with infusion specific features as specified in the respective subgroups.

Infusion catheters are usually longer than infusion cannulas, but nomenclature in this field is often not consistent.

Illustrative example of subject matter classified in this place:

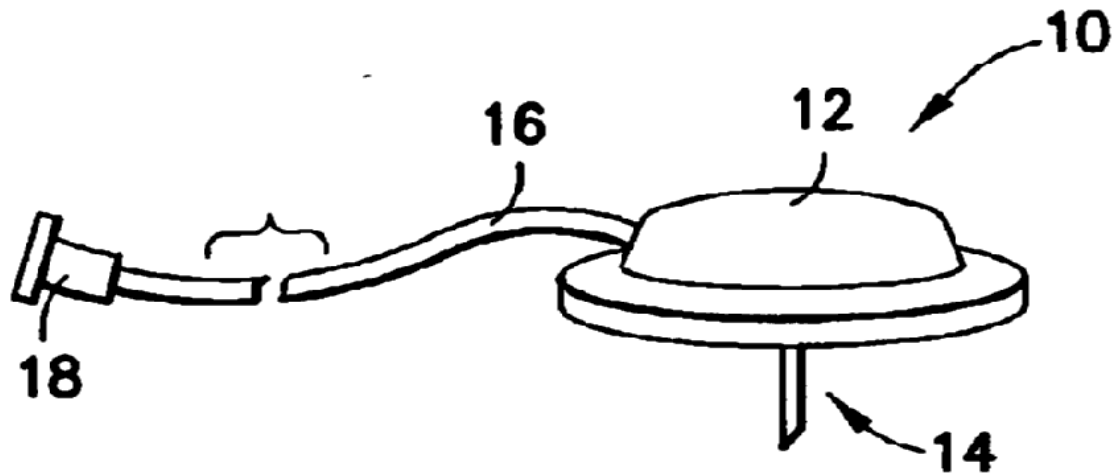

Relationship with other classification places

Catheters are classified in group [A61M 25/00](#). A catheter used for infusions is usually inserted with a guidewire and provides an infusion distant from the piercing site.

Devices with body piercing needle for injection (syringes and related devices) are classified in group [A61M 5/32](#) and its subgroups.

A61M 2005/1581

Definition statement

This place covers:

Devices comprising a needle that is bent at a right angle.

Illustrative example of subject matter classified in this place:

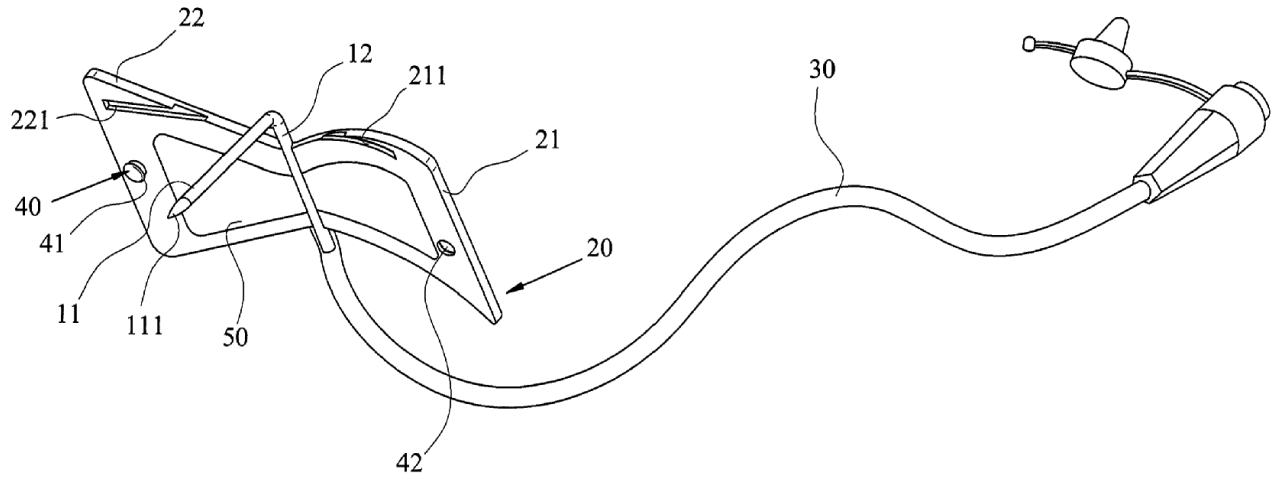

A61M 5/1582

Definition statement

This place covers:

Illustrative example of subject matter classified in this place:

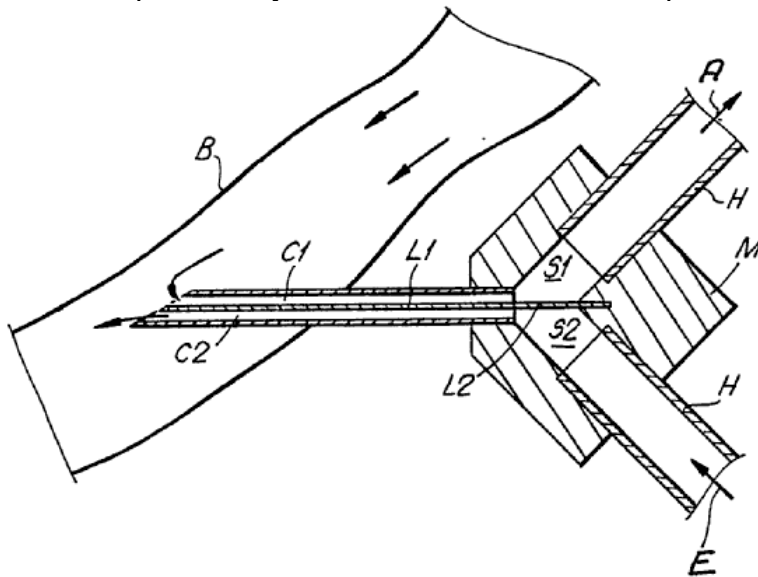

A61M 2005/1583

Definition statement

This place covers:

Devices for extracting or de-attaching needles and their respective base from the patient's body.

This also applies to needle retracting mechanisms arranged in infusion sets or skin adhering patch pumps.

Illustrative example of subject matter classified in this place:

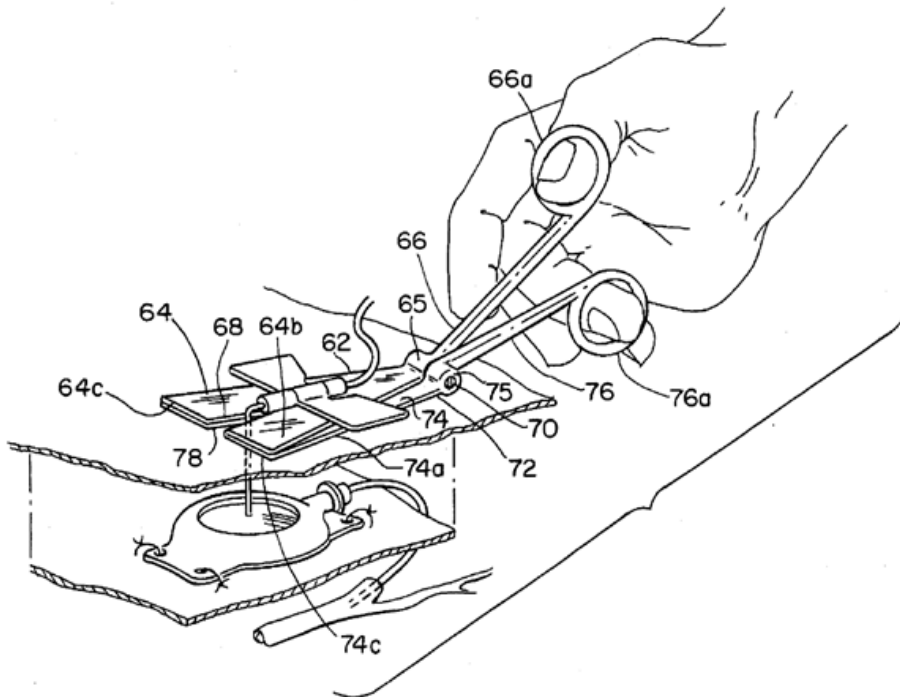

A61M 2005/1585

Definition statement

This place covers:

DATE: AUGUST 1, 2026

PROJECT RP11946

Mechanisms for needle introduction.

Devices for inserting a needle into the body. The needle may be inserted alone or carry a cannula that will remain in the body.

Illustrative example of subject matter classified in this place:

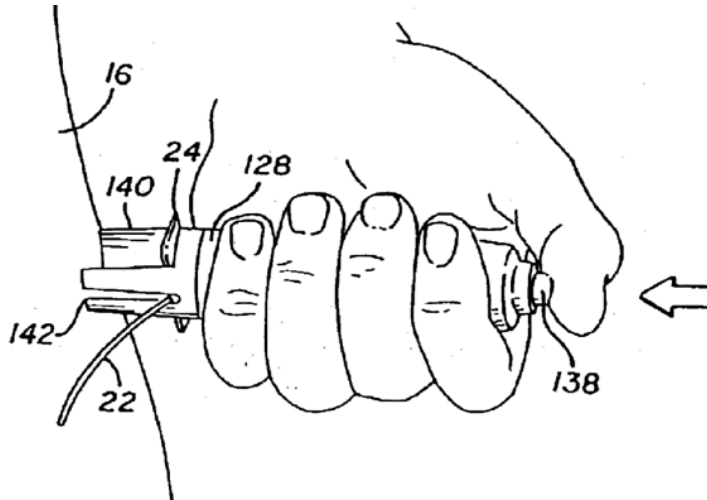

The Figure illustrates a mechanism for allowing a user to provide an insertion force to needle set (24).

A61M 2005/1587

Definition statement

This place covers:

Features of an infusion set which relate to the fluid line and its connection to a fluid source.

Needles structurally suitable for being connected to an infusion line.

Illustrative example of subject matter classified in this place:

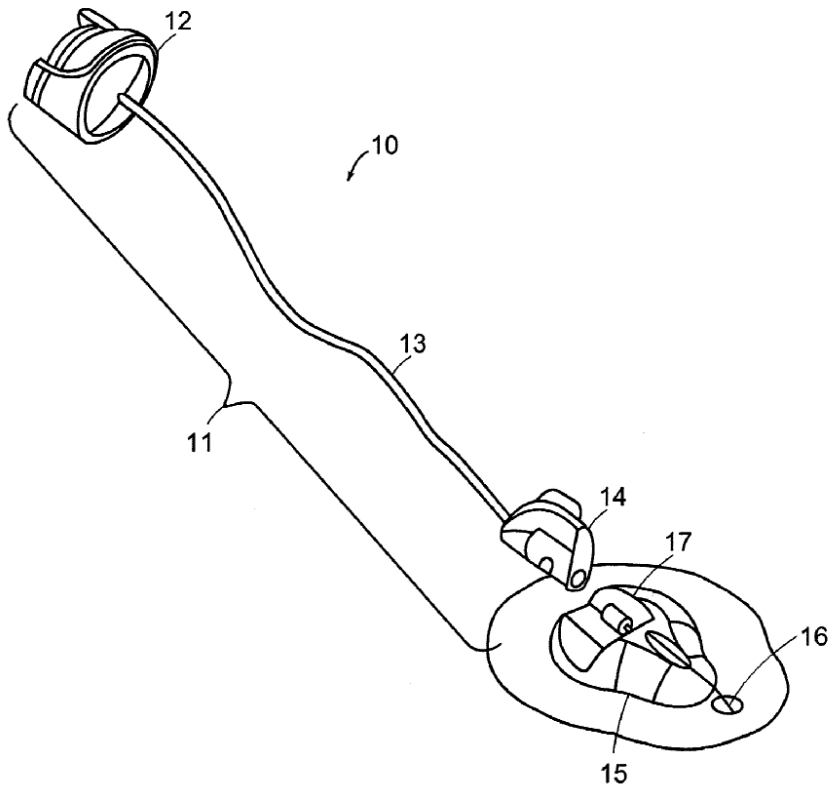

A61M 2005/1588

Definition statement

This place covers:

Infusion needles (including those found on infusion sets) with any kind of sensing, controlling or inspection means to detect, control or just visualise normal or irregular function.

Illustrative example of subject matter classified in this place:

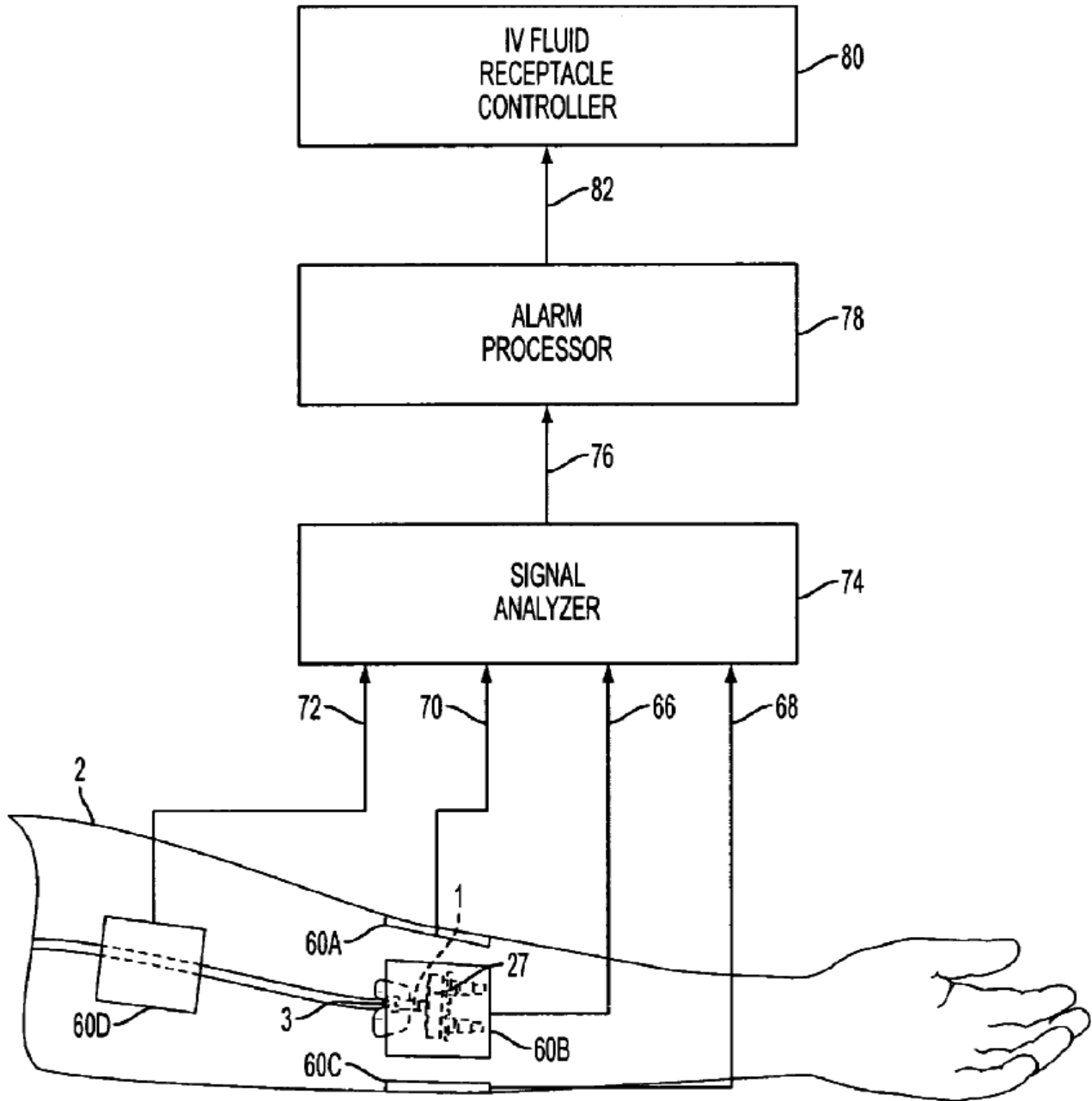

A61M 5/162

Definition statement

This place covers:

Needle sets with a spike or spike-like proximal connection component for connection of the infusion line to a fluid supply component, such as an infusion bag.

Illustrative example of subject matter classified in this place:

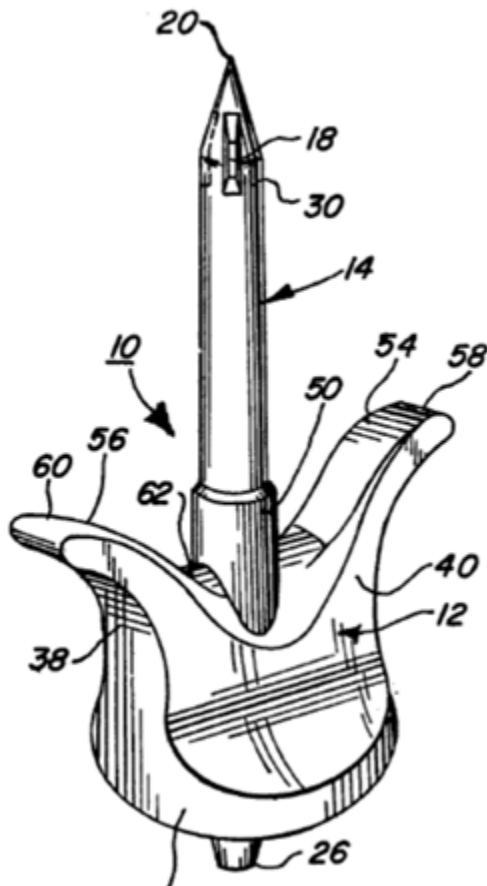

The Figure illustrates the spike (14) of a needle set for proximal connection.

DATE: AUGUST 1, 2026

PROJECT RP11946

References

Informative references

Attention is drawn to the following places, which may be of interest for search:

Connections between reservoir and tube in jet-action syringes	A61M 5/30
Connectors for tubes having sealed ends and a needle for piercing them	A61M 39/14

Special rules of classification

Classification in this place should only be given for features relating to the proximal connection component.

A61M 2005/1623

Definition statement

This place covers:

Venting means usually provided in or in combination with the needle set to avoid under-pressure in an infusion bottle.

Illustrative example of subject matter classified in this place:

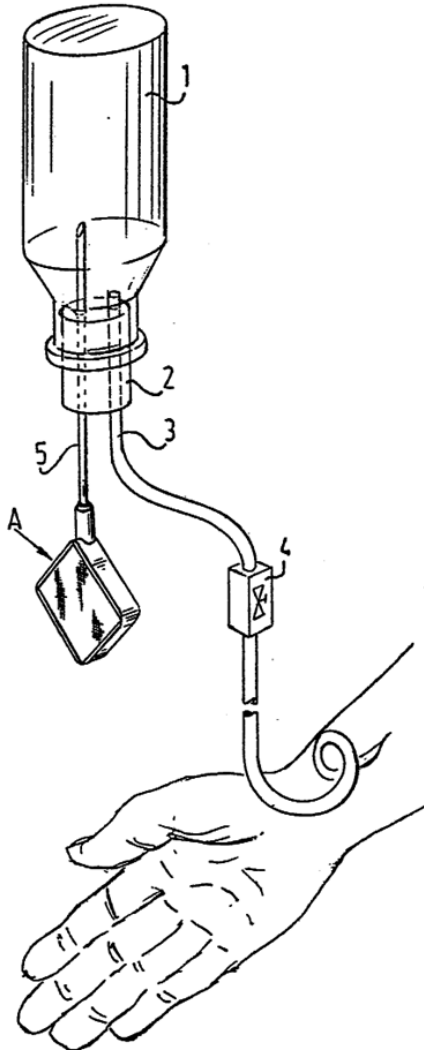

The Figure illustrates a filter element (A) which allows air to enter the infusion container (1) while at the same time preventing the liquid contents from escaping.

A61M 5/1626

Definition statement

This place covers:

All types of needle cover for infusion devices, including those on the distal side of an infusion set.

Illustrative examples of subject matter classified in this place:

1.

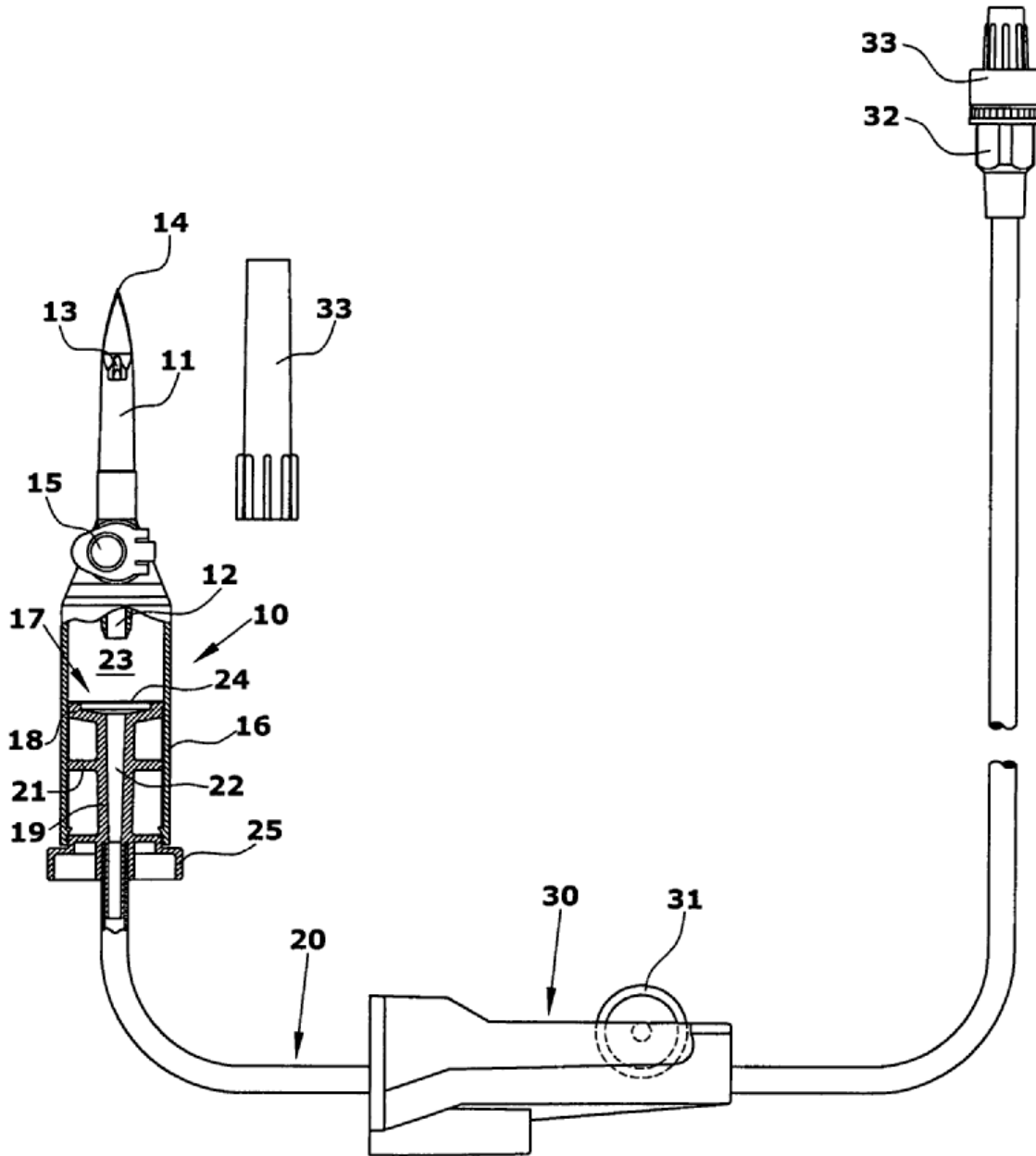

Figure 1 illustrates a cover (33) for spike (11) which is intended for insertion into an infusion bag.

2.

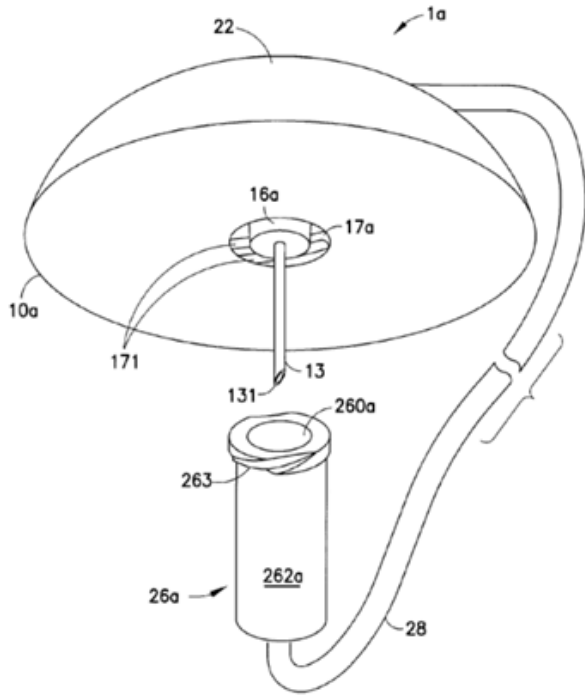
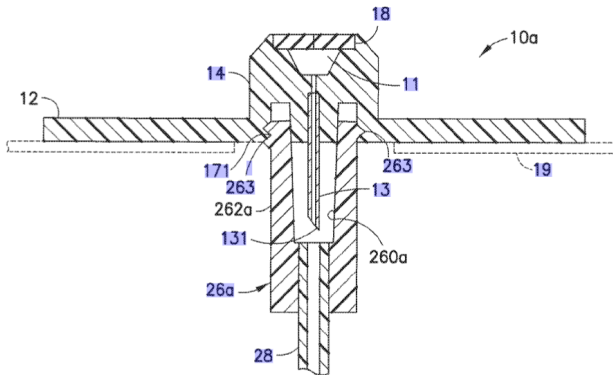

Figure 2 illustrates a proximal connector (262a) which also functions as a protector for the distal needle (13).

3.



CPC NOTICE OF CHANGES 1933

DATE: AUGUST 1, 2026

PROJECT RP11946

References

Limiting references

This place does not cover:

Needle protectors in combination with syringes	A61M 5/3202
Protectors for sharps	A61B 50/3001

A61M 5/165

Definition statement

This place covers:

Filters used in or in combination with infusion equipment for filtering an infusion liquid or air which enters an infusion reservoir.

Illustrative example of subject matter classified in this place:

1.

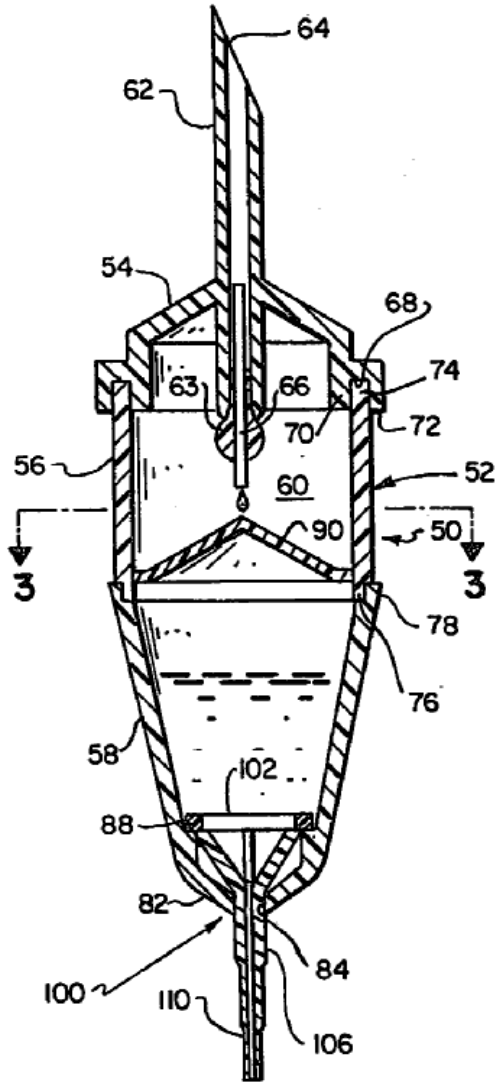

Figure 1 illustrates a drip chamber comprising a filter membrane (90).

2.

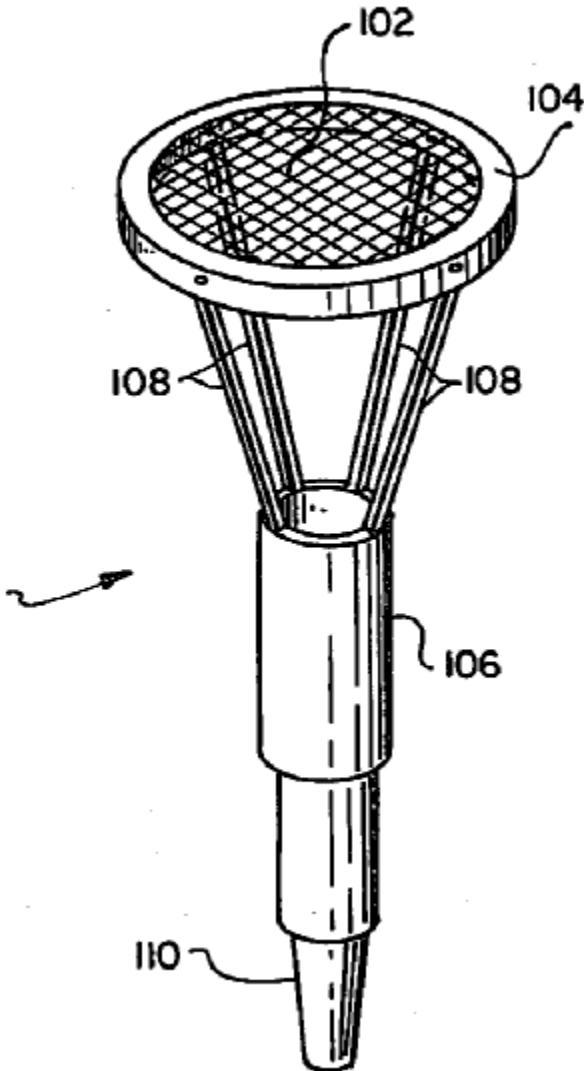

Figure 2 illustrates a filter arrangement that can be used in a drip chamber (as illustrated in Figure 1 above).

References

Limiting references

This place does not cover:

Filtering material out of blood	A61M 1/34
Degassing devices	A61M 1/3627
Blood treatment by absorption	A61M 1/3679

DATE: AUGUST 1, 2026

PROJECT RP11946

Chemical treatment of blood	A61M 1/3687
Means for eliminating or preventing injection of air into the human body	A61M 5/36

A61M 5/168**Definition statement***This place covers:*

Devices for setting or controlling a flow rate with or without pumping means. Functional aspects relating to the flow rate control in pumping devices.

References**Informative references***Attention is drawn to the following places, which may be of interest for search:*

Flow control in general	G05D 7/00
-------------------------	---------------------------

A61M 5/16804**Definition statement***This place covers:*

Devices either with or without fluid pumping means for administering a fluid to a patient at an actively controlled flow rate. The devices typically comprise means for setting a flow rate, as well as additional means to dynamically control, i.e. alter, the flow rate.

Relationship with other classification places

Where the administration solely consists of setting a flow rate, e.g. with a passive valve mechanism for sustaining a desired flow rate, group [A61M 5/16877](#) should be allocated.

CPC NOTICE OF CHANGES 1933

DATE: AUGUST 1, 2026

PROJECT RP11946

A61M 5/16809

Definition statement

This place covers:

Devices having an intermediate volume such as dosing chamber of constant or variable volume.

Illustrative example of subject matter classified in this place:

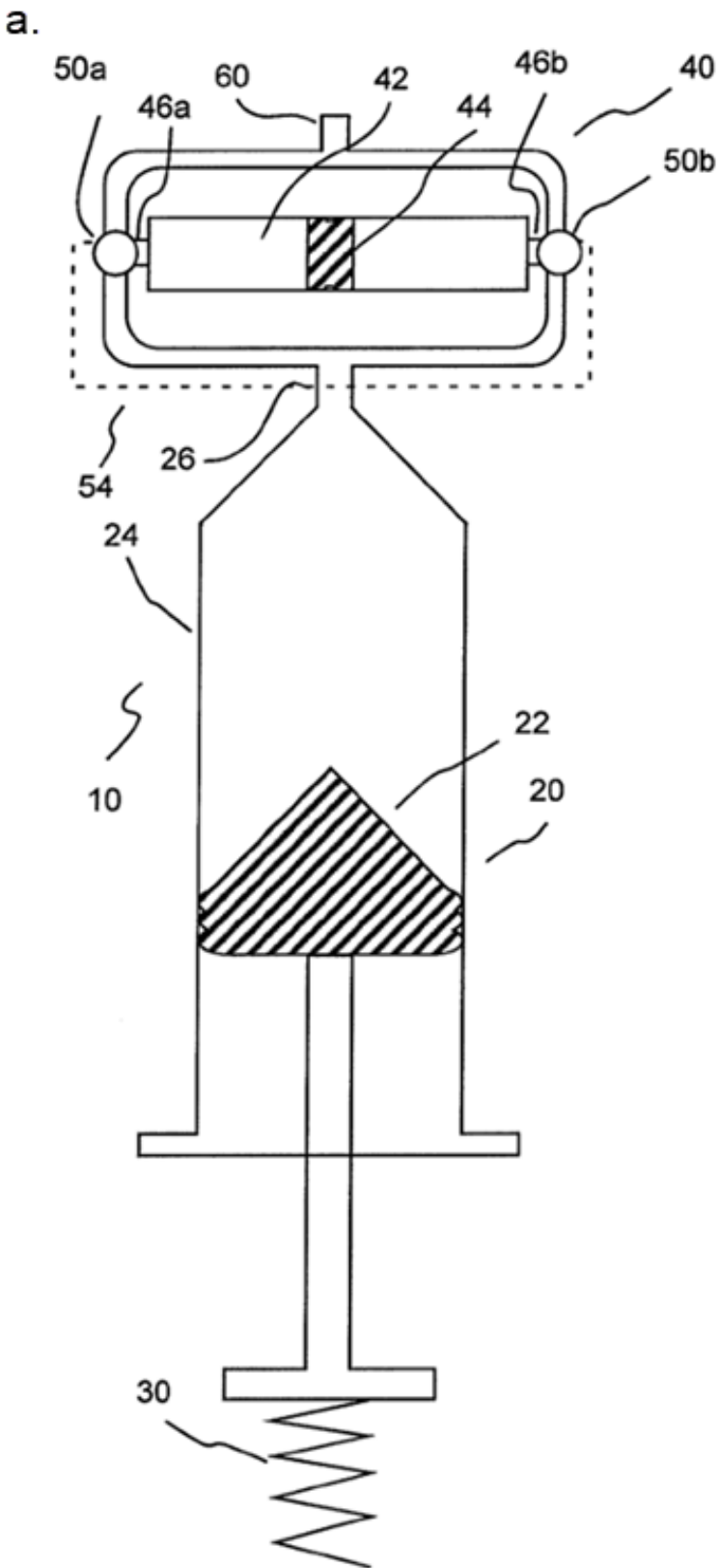

Figure a. illustrates a device (40) with passively movable piston (44) filled from pressurised reservoir (20). The infusion is controlled by selective actuation of valves (50a and 50b).

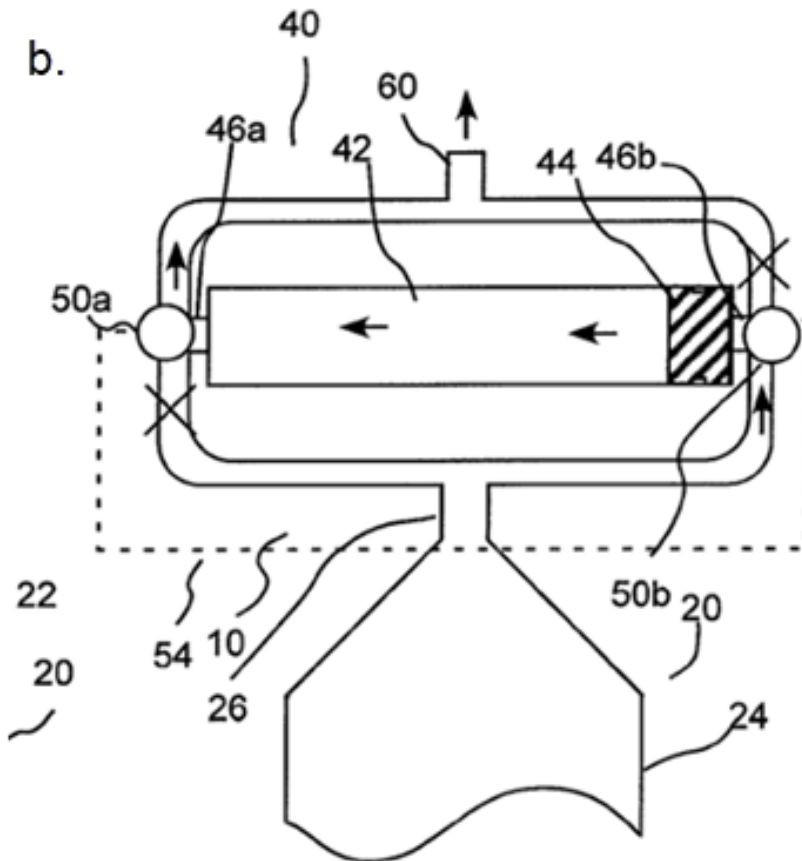

Figure b. illustrates a movable piston (44) being actuated by valve (50b) to supply pressure toward valve (50a).

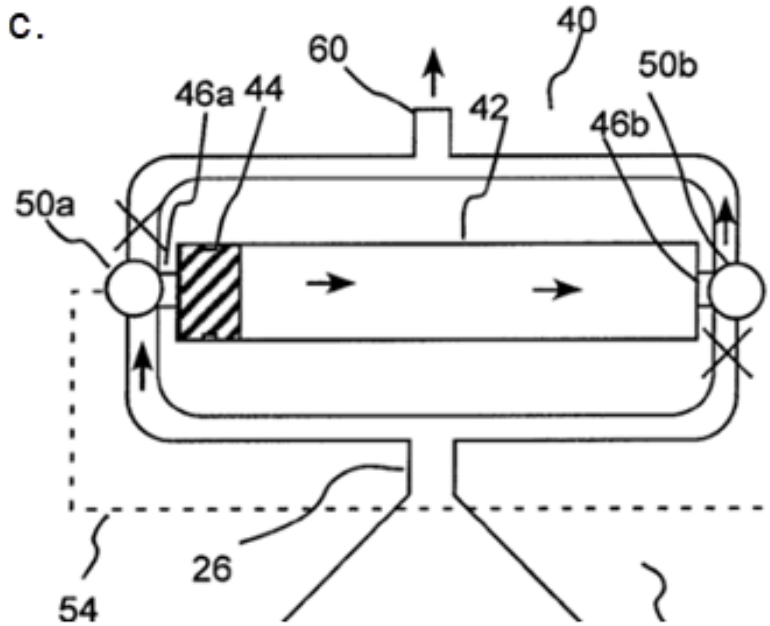

Figure c. illustrates a movable piston (44) being actuated by valve (50a) to supply pressure toward valve (50b).

References

Informative references

Attention is drawn to the following places, which may be of interest for search:

Pressure infusion using positive displacement pumps	A61M 5/142
---	----------------------------

A61M 5/16813

Definition statement

This place covers:

Flow controllers in which the flow resistance is altered by changing the cross section of the flow line. This may be done gradually to provide a defined resistance, or by temporary closing (and opening) a valve element to provide the desired flow rate.

Illustrative example of subject matter classified in this place:

DATE: AUGUST 1, 2026

PROJECT RP11946

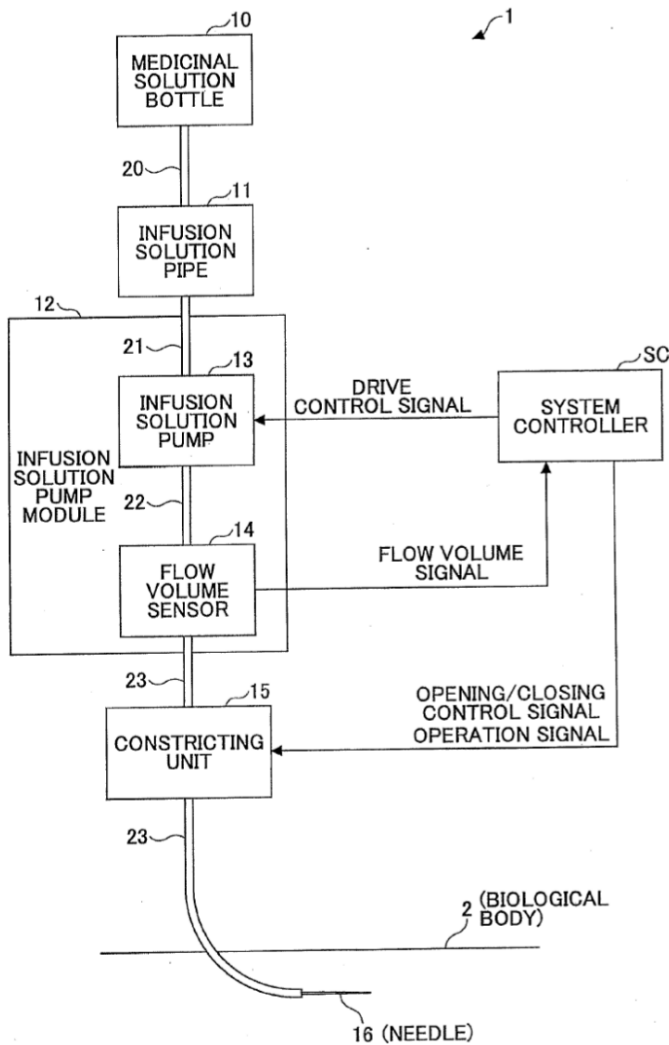

The Figure illustrates how the system controller generates a signal based on the reading of the flow volume sensor (14) to open and close the constricting unit (15) to obtain a desired flow rate.

A61M 5/16818

Definition statement

This place covers:

Devices with means for adjusting or changing a height of a reservoir or intermediate volume.

Illustrative example of subject matter classified in this place:

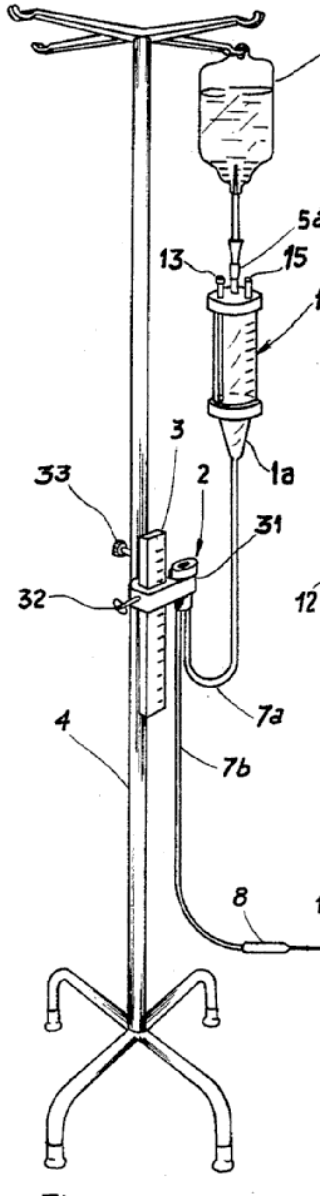

A61M 5/16822

Definition statement

This place covers:

Devices in which a flow rate is determined by means of the air pressure in the reservoir means, which is in turn controlled by venting means allowing air to enter the reservoir.

Illustrative examples of subject matter classified in this place:

1.

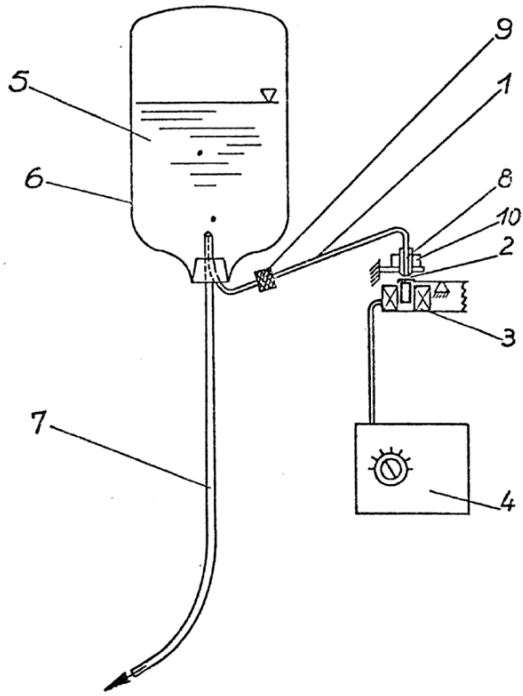

2.

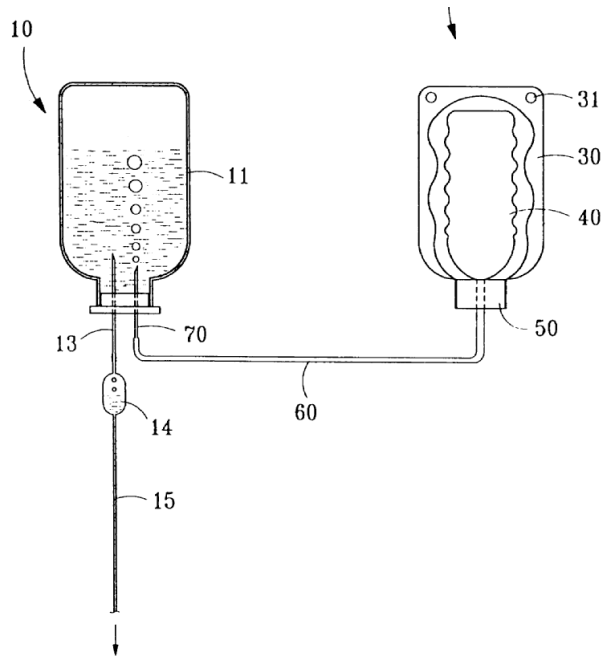

A61M 5/16827

Definition statement

This place covers:

Adjusting or controlling the flow from different reservoirs to the patient.

Illustrative example of subject matter classified in this place:

CPC NOTICE OF CHANGES 1933

DATE: AUGUST 1, 2026

PROJECT RP11946

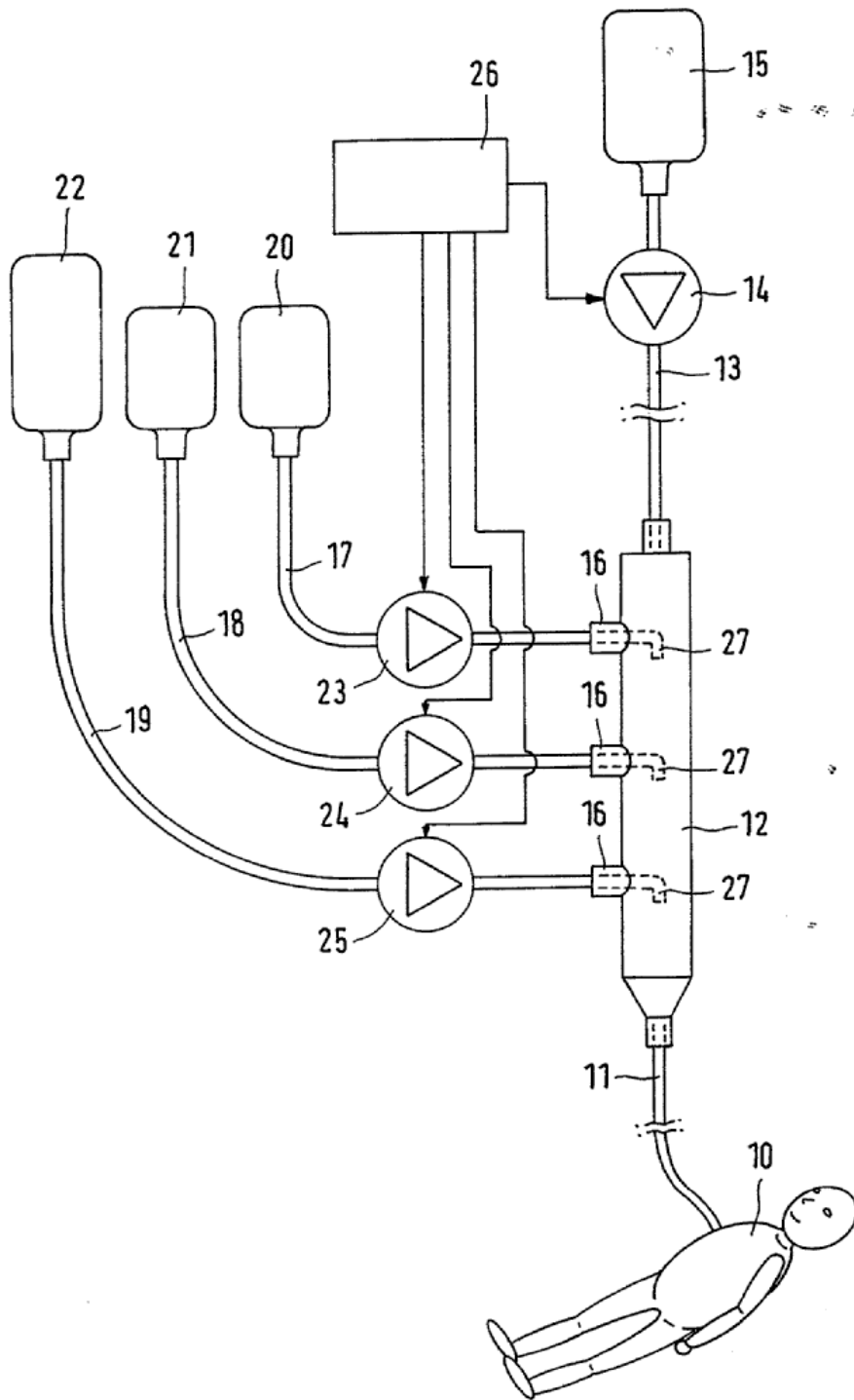

References

Limiting references

This place does not cover:

Infusion of multiple fluids without using a controller	A61M 5/1407
--	-----------------------------

A61M 5/16836

Definition statement

This place covers:

Sensing means located on or proximate to the infusion site and detecting tissue related anomalies, such as fluid leakage or extravasation.

Illustrative example of subject matter classified in this place:

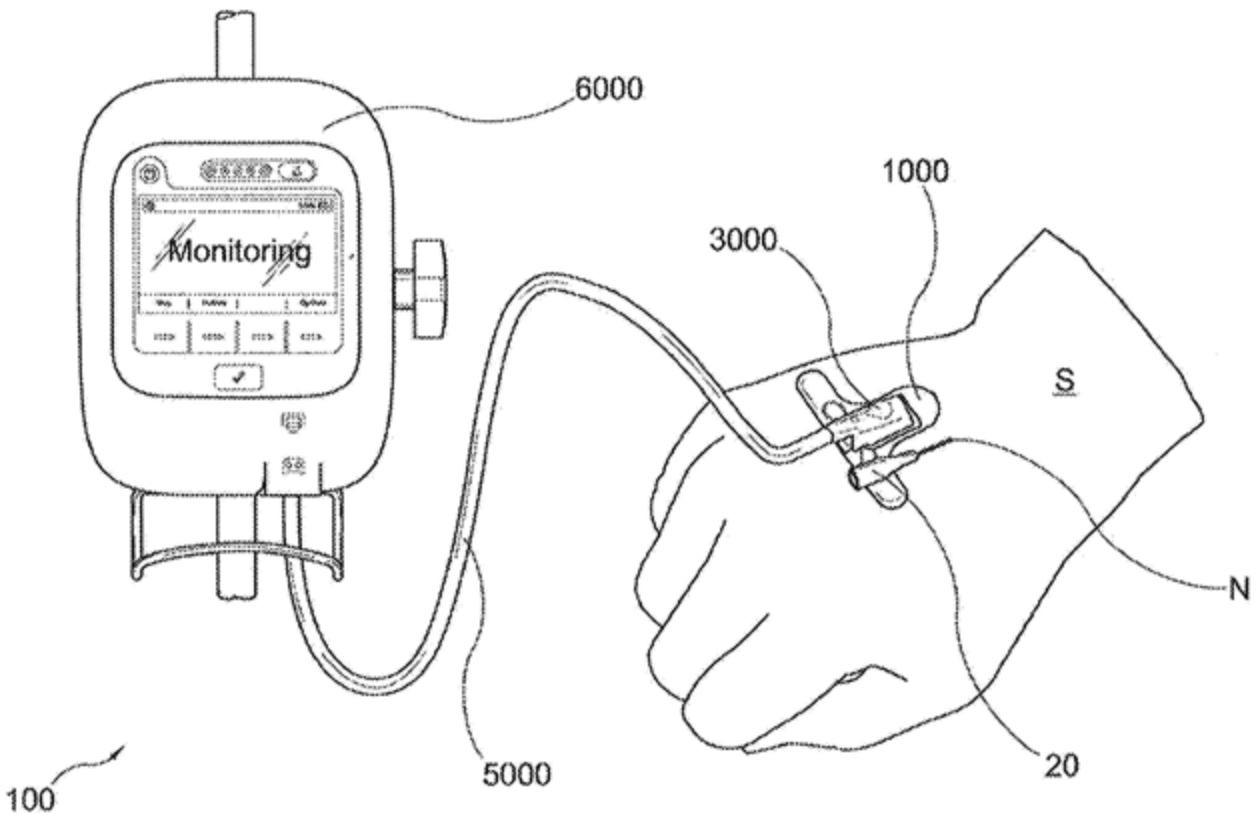

A61M 5/1684

Definition statement

This place covers:

Means or functional aspects relating to the determination of the fluid volume remaining in a reservoir.

Illustrative example of subject matter classified in this place:

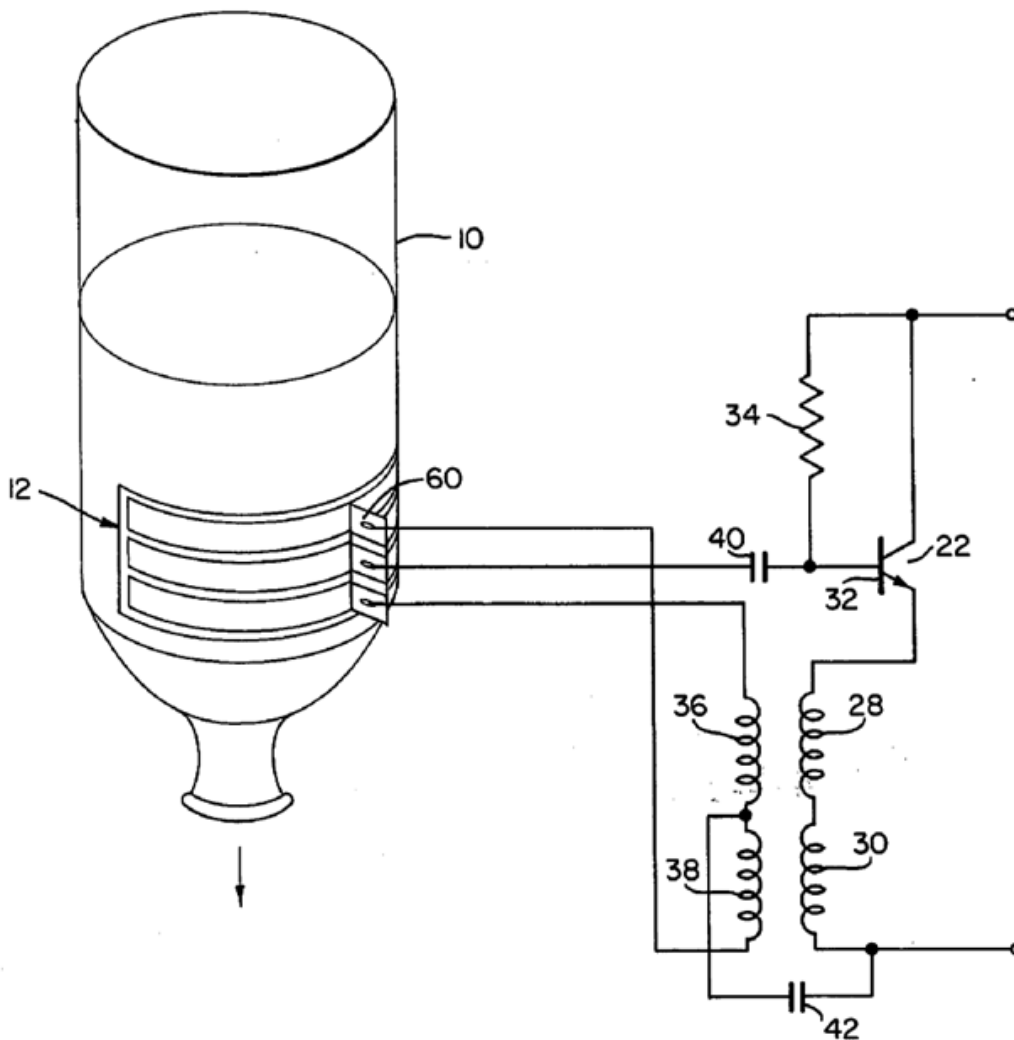

A61M 5/16845

Definition statement

This place covers:

The determination of the fluid volume in the reservoir by a weight measurement, such as a scale.

Illustrative example of subject matter classified in this place:

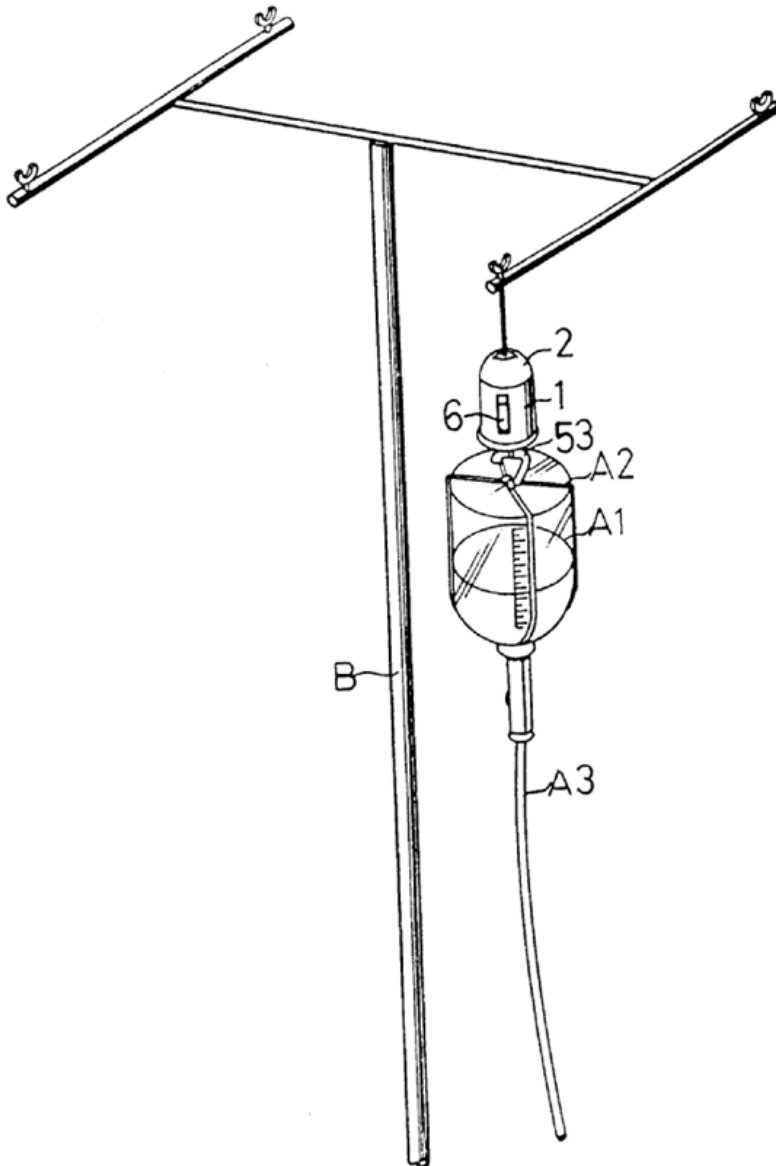

DATE: AUGUST 1, 2026

PROJECT RP11946

References

Informative references

Attention is drawn to the following places, which may be of interest for search:

Means for measuring fluid flow rate by monitoring weight change, e.g. of infusion container	A61M 5/16895
---	------------------------------

A61M 5/1685

Definition statement

This place covers:

Detection of the position of a member floating or located on the surface of the fluid in the reservoir or an intermediate chamber in the flow line.

Illustrative example of subject matter classified in this place:

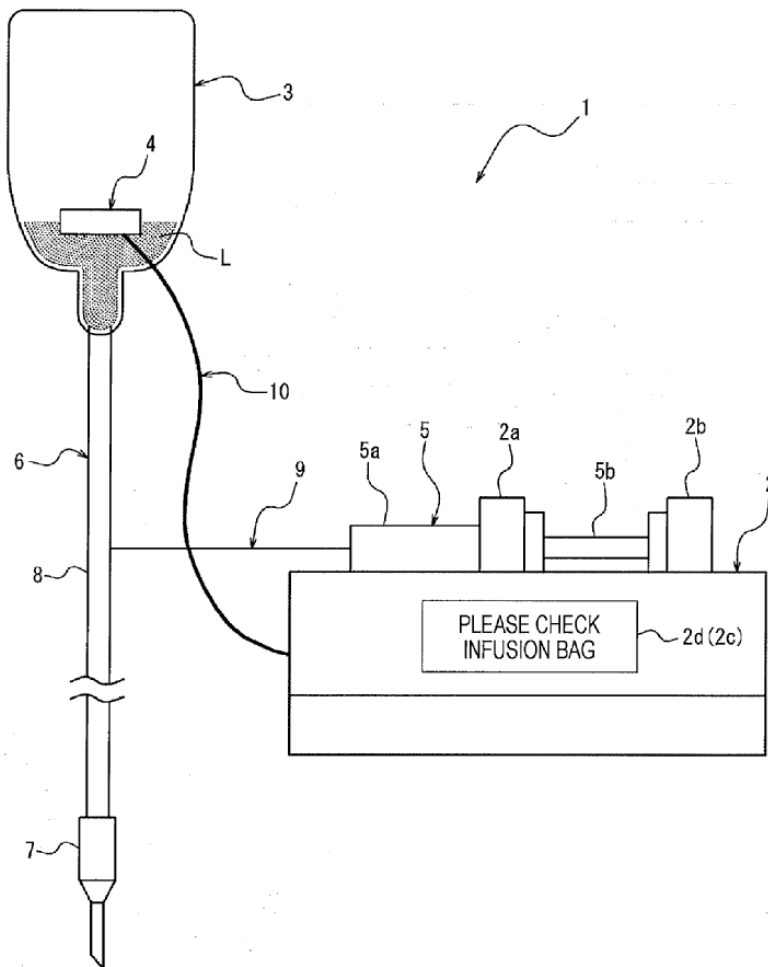

A61M 5/16854

Definition statement

This place covers:

Means for sensing a pressure in the infusion arrangement to detect flow anomalies.

DATE: AUGUST 1, 2026

PROJECT RP11946

A61M 5/16859

Definition statement

This place covers:

Means for sensing a pressure response to a dedicated excitation signal, such as a pressure pulse.

A61M 5/16863

Definition statement

This place covers:

Means for sensing an occlusion in the infusion arrangement.

A61M 5/16877

Definition statement

This place covers:

Devices for setting a flow rate of a fluid administration to a patient within the fluid line, e.g. valve means with adjustable or interchangeable cross section for setting the degree of the opening of the flow line.

Illustrative example of subject matter classified in this place:

DATE: AUGUST 1, 2026

PROJECT RP11946

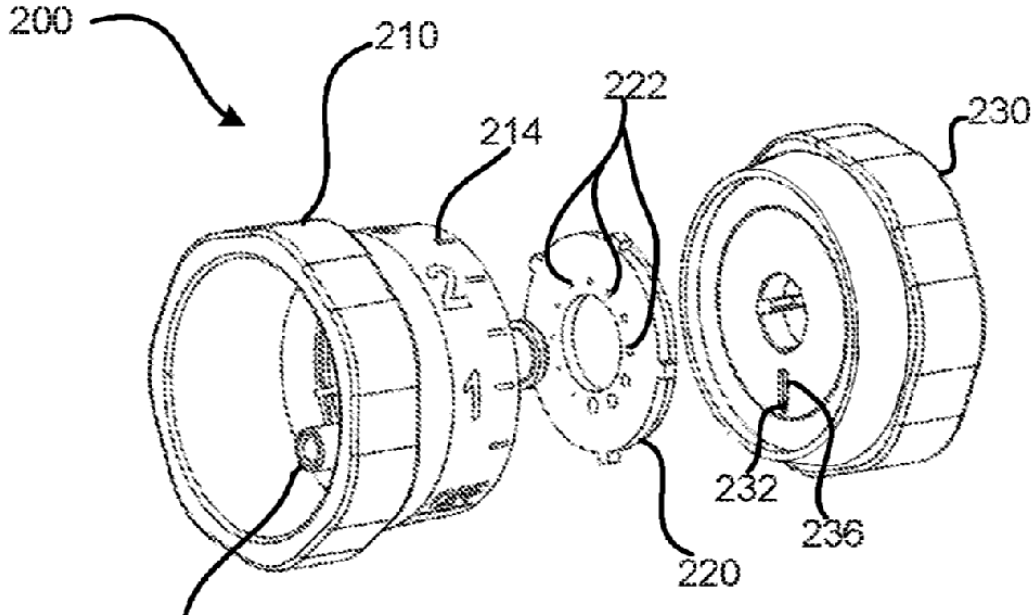

The Figure illustrates a device for setting a flow rate by rotation of part (210). This causes the concomitant rotation of disc (220) which is provided with a plurality of flow restriction apertures or holes (222) of different diameters.

Relationship with other classification places

When the device comprises an active control means for flow rate manipulation, group [A61M 5/16804](#) (or the appropriate subgroups thereof) should be allocated.

References

Limiting references

This place does not cover:

Clamp-type valves	A61M 39/28
-------------------	----------------------------

A61M 5/16881

Definition statement

This place covers:

Flow setting means comprising a valve that self-regulates the flow to sustain the set flow rate. For example, the valve may have a membrane which is subject to fluid pressure and regulates the flow by providing a pressure dependent flow resistance.

Illustrative example of subject matter classified in this place:

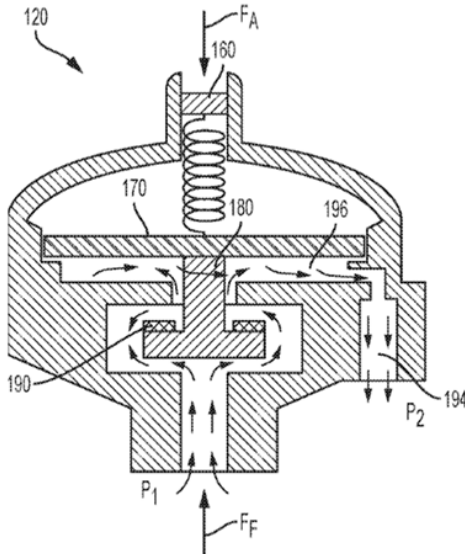

The Figure illustrates a pressurised administration fluid opening a valve (190) by acting against a spring force which provides a certain flow resistance during administration.

A61M 5/16886

Definition statement

This place covers:

Means or functional aspects relating to the measurement of a flow rate.

CPC NOTICE OF CHANGES 1933

DATE: AUGUST 1, 2026

PROJECT RP11946

A61M 5/1689

Definition statement

This place covers:

Measurement means which measure a flow rate or flow volume by counting drops.

Illustrative example of subject matter classified in this place:

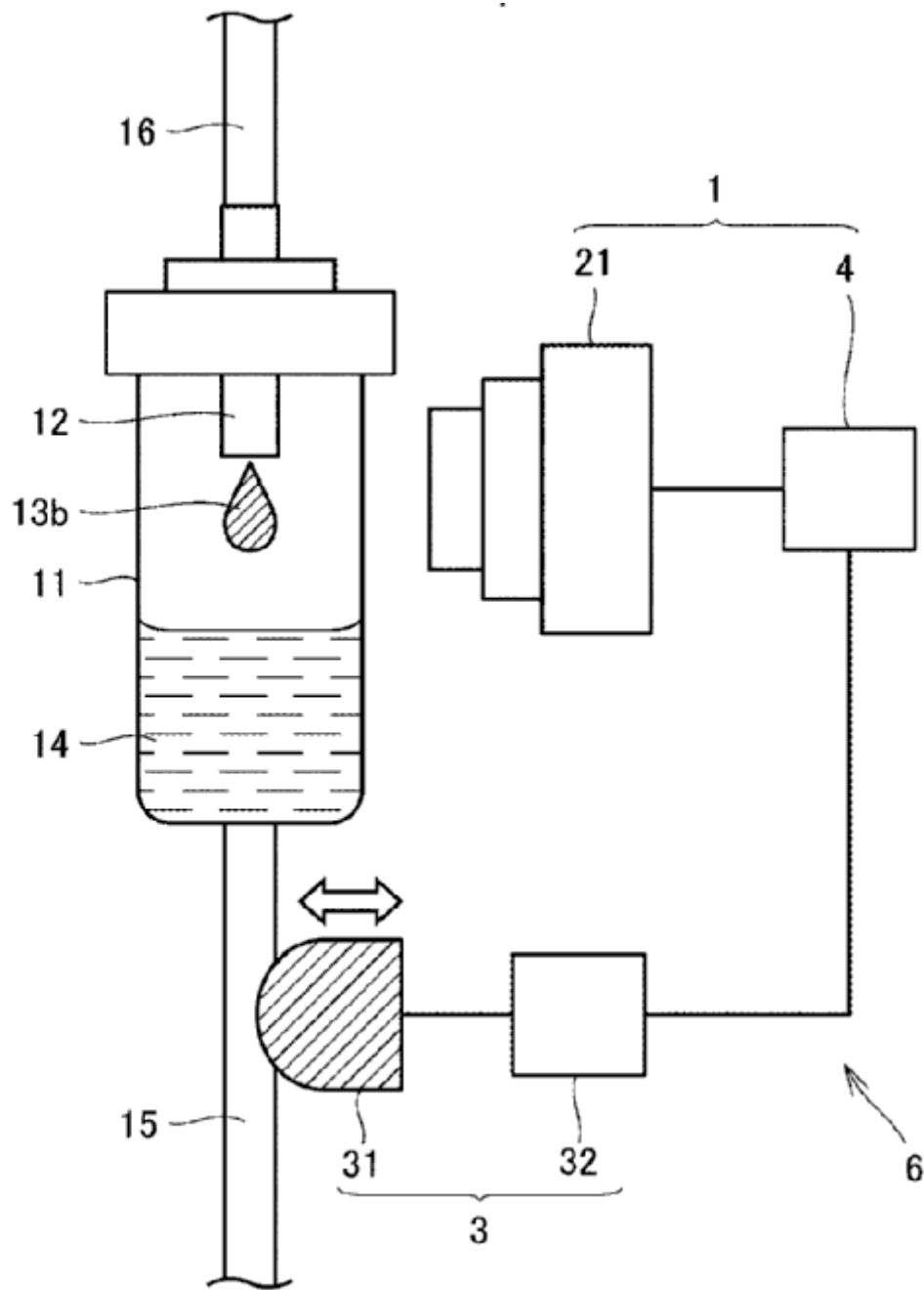

The Figure illustrates an arrangement in which drops are counted by optical detection using a camera (21).

DATE: AUGUST 1, 2026

PROJECT RP11946

References**Informative references**

Attention is drawn to the following places, which may be of interest for search:

Drip chamber	A61M 5/1411
--------------	-----------------------------

A61M 5/16895**Definition statement**

This place covers:

Devices which measure a change in weight (e.g. of the infusion container) to determine a resulting flow rate.

Relationships with other classification places

Group [A61M 5/16895](#) should be given in cases where a determination of remaining fluid volume in the reservoir is involved. Group [A61M 5/1684](#) is used to determine the fluid flow rate.

A61M 5/172**References****Informative references**

Attention is drawn to the following places, which may be of interest for search:

Flow controllers	A61M 5/16804
Monitoring, detecting, signalling or eliminating infusion flow anomalies	A61M 5/16831

DATE: AUGUST 1, 2026

PROJECT RP11946

A61M 5/1723

Definition statement

This place covers:

Means or functional aspects relating to the sensing of patient specific parameters, and using them to control the infusion device.

Illustrative example of subject matter classified in this place:

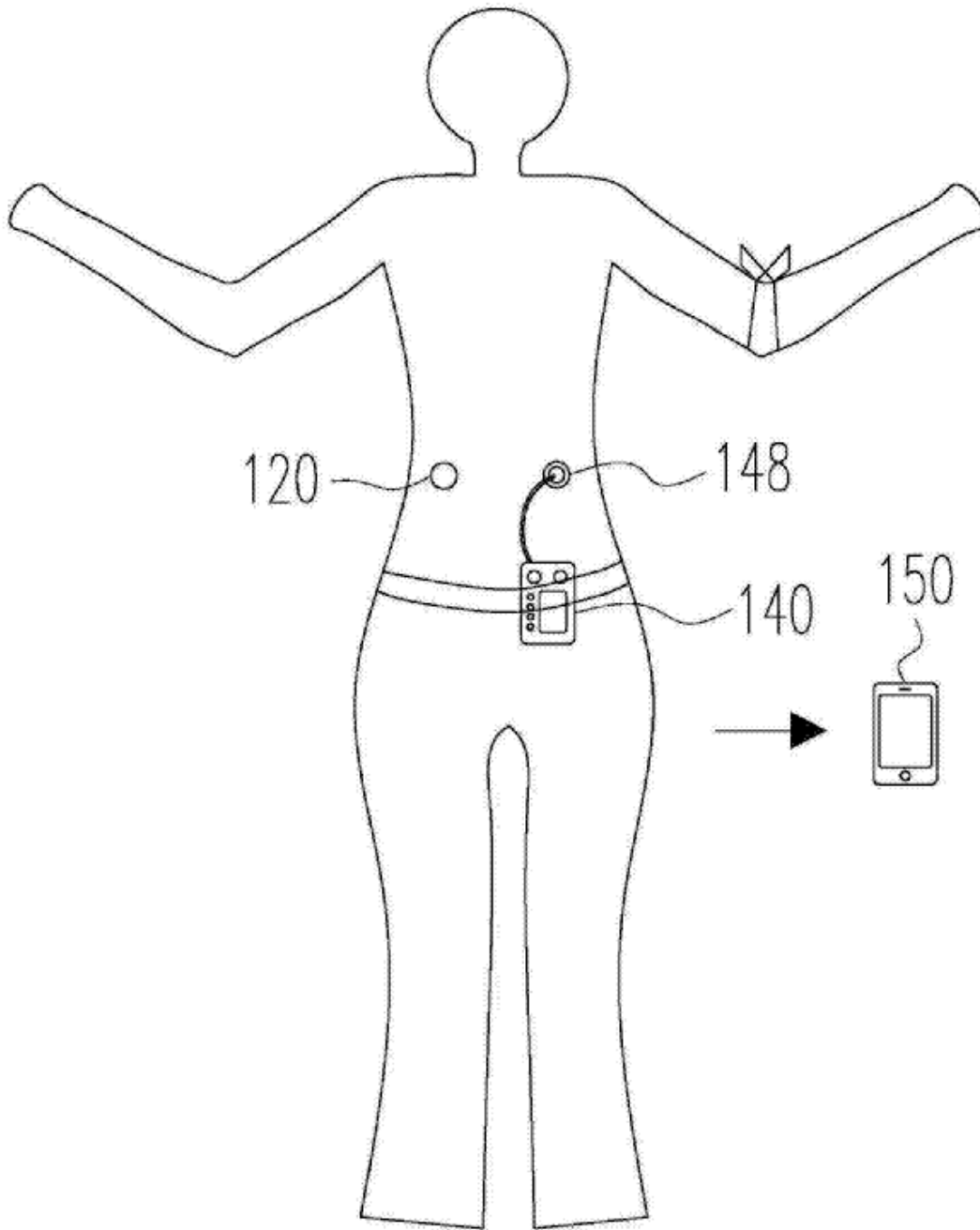

DATE: AUGUST 1, 2026

PROJECT RP11946

References

Informative references

Attention is drawn to the following places, which may be of interest for search:

Measurement of body parameters without link to infusion control	A61B 5/00
ICT relating to the processing of sensor feedback for infusion control	G16H 20/17

A61M 2005/1726

Definition statement

This place covers:

Sensing elements either located on the infusion cannula, the infusion device or particularly close to the infusion site on the patient body.

Illustrative example of subject matter classified in this place:

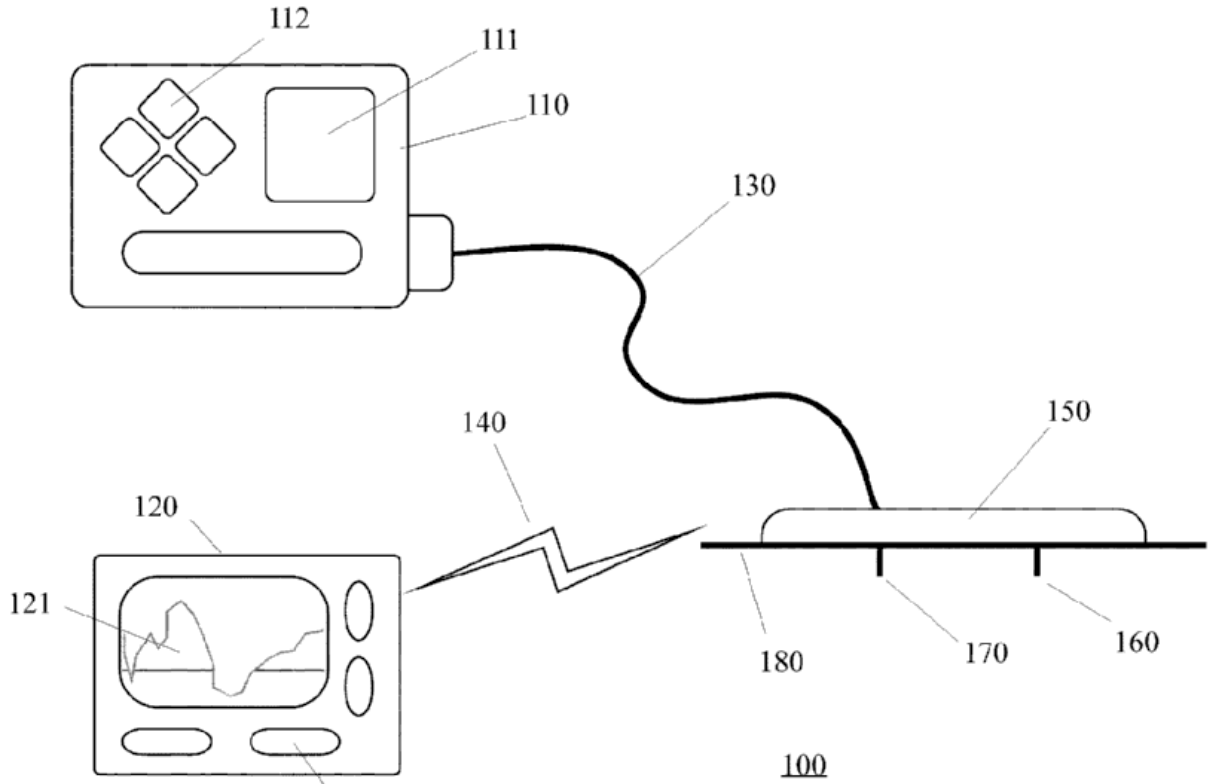

The Figure illustrates a needle set (150) which comprises an injection cannula (170) and a sensing probe (160).

References

Informative references

Attention is drawn to the following places, which may be of interest for search:

Infusion devices	A61M 5/14
Manufacture of syringes or needles	B29L 2031/7544

A61M 5/1782

Definition statement

This place covers:

Devices used to fill or refill the syringe during use (of the syringe, i.e. in situ).

Illustrative examples of subject matter classified in this place:

1.

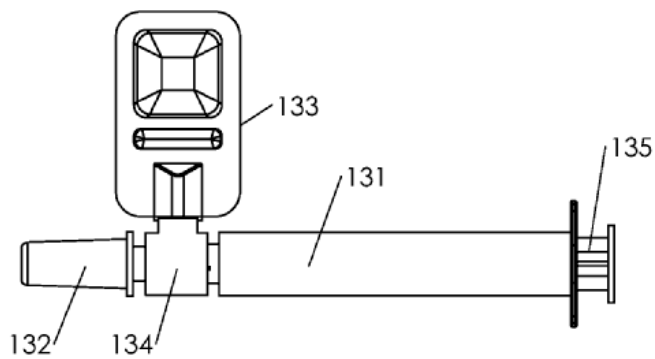

Figure 1 illustrates a syringe (131) which can be refilled from reservoir (133) by means of valve element (134).

2.

DATE: AUGUST 1, 2026

PROJECT RP11946

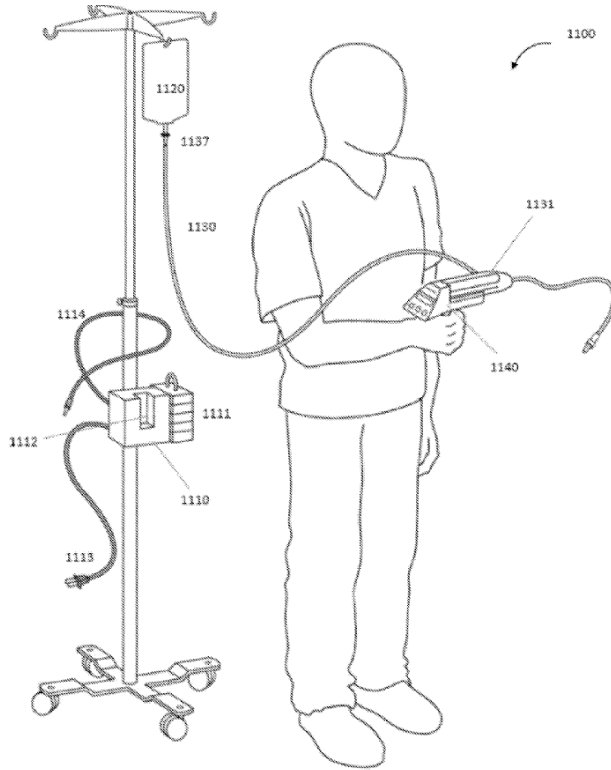

Figure 2 illustrates a syringe injector (1140) which is replenished from an infusion bag (1120).

References

Limiting references

This place does not cover:

Combination of a vial and a syringe for transferring or mixing their contents	A61J 1/2096
Filling of medical containers in general	B65B 3/003

A61M 5/1785

Definition statement

This place covers:

Syringes having a radioactive shielding either inherently (e.g. shielding material incorporated in the syringe barrel) or associated with the syringe (e.g. a separate shielding means attached to or covering the syringe).

Illustrative example of subject matter classified in this place:

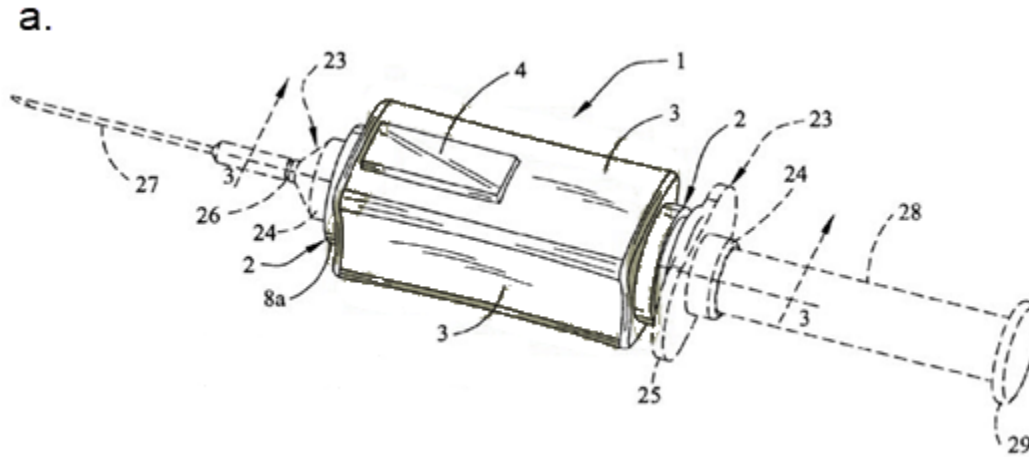

Figure a. illustrates a syringe (24) with a separate shield (1) that is attachable to the syringe (24).

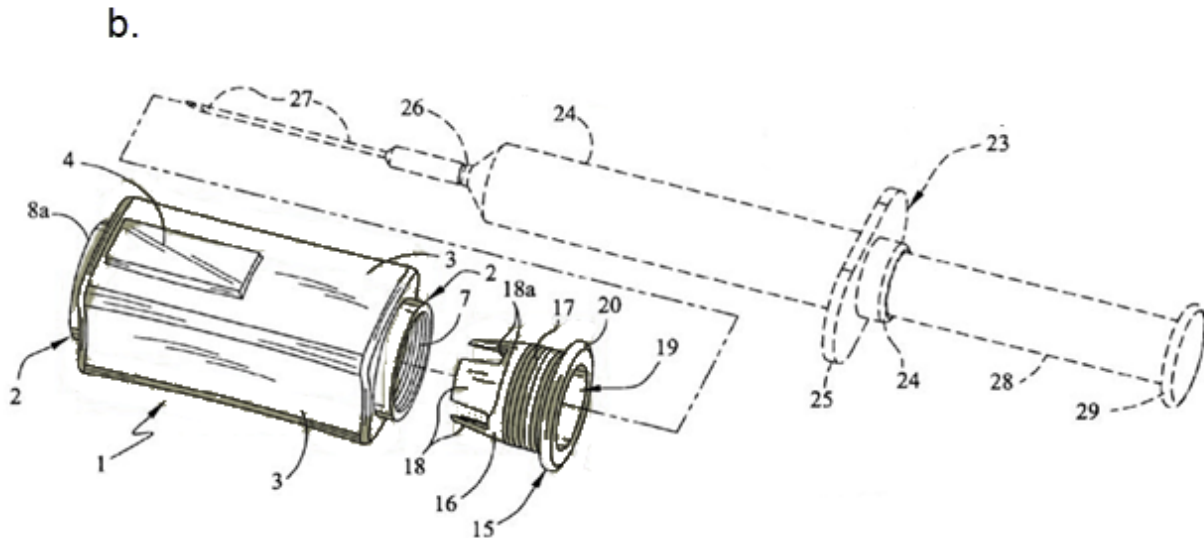

Figure b. illustrates the separate shield (1) detached from the syringe (24).

References

Limiting references

This place does not cover:

Containers for transporting or storing syringes containing radioactive material	G21F 5/018
---	------------

A61M 2005/1787

Definition statement

Illustrative example of subject matter classified in this place:

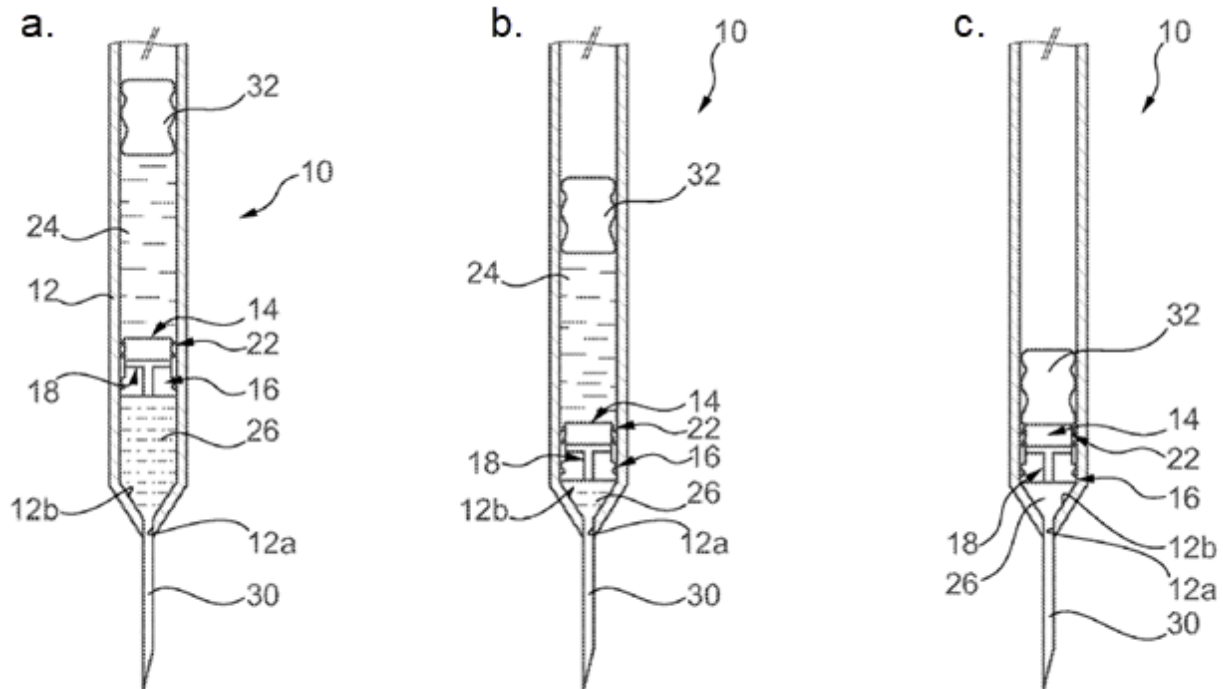

The Figure illustrates fluid (24) being dispensed via valve means in plunger (22).

DATE: AUGUST 1, 2026

PROJECT RP11946

A61M 5/19**Definition statement***This place covers:*

Syringes having more than one chamber. This also includes a manifold coupling two (e.g. parallelly aligned) syringes through separate channels to a common discharge assembly.

References**Limiting references***This place does not cover:*

Surgical glue applicators	A61B 17/00491
---------------------------	-------------------------------

Informative references*Attention is drawn to the following places, which may be of interest for search:*

Automatic syringes comprising means for injecting two or more media, e.g. by mixing	A61M 5/2066
Ampoule syringes comprising means for injecting two or more media, e.g. by mixing	A61M 5/2448
Syringe ampoules comprising means for injecting two or more media, e.g. by mixing	A61M 5/284
Pistons comprising means for injecting two or more media, e.g. by mixing	A61M 5/31596

A61M 5/20**Definition statement***This place covers:*

Syringes or injectors having a fully or semi-automatic drive means for causing ejection of the drug.

Different aspects of such automatic syringes or injectors such as triggering of the discharging means or cocking means not covered in other groups.

Illustrative examples of subject matter classified in this place:

1.

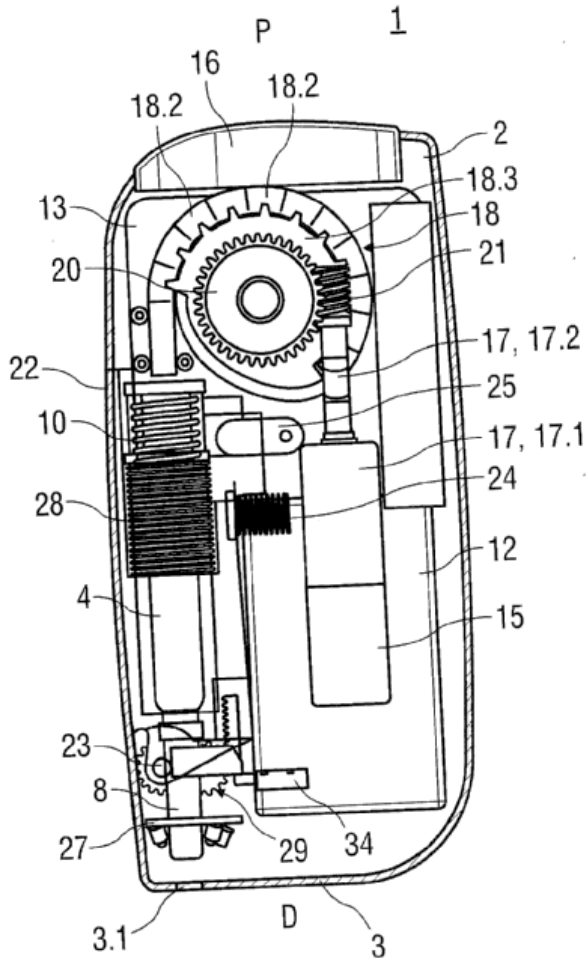
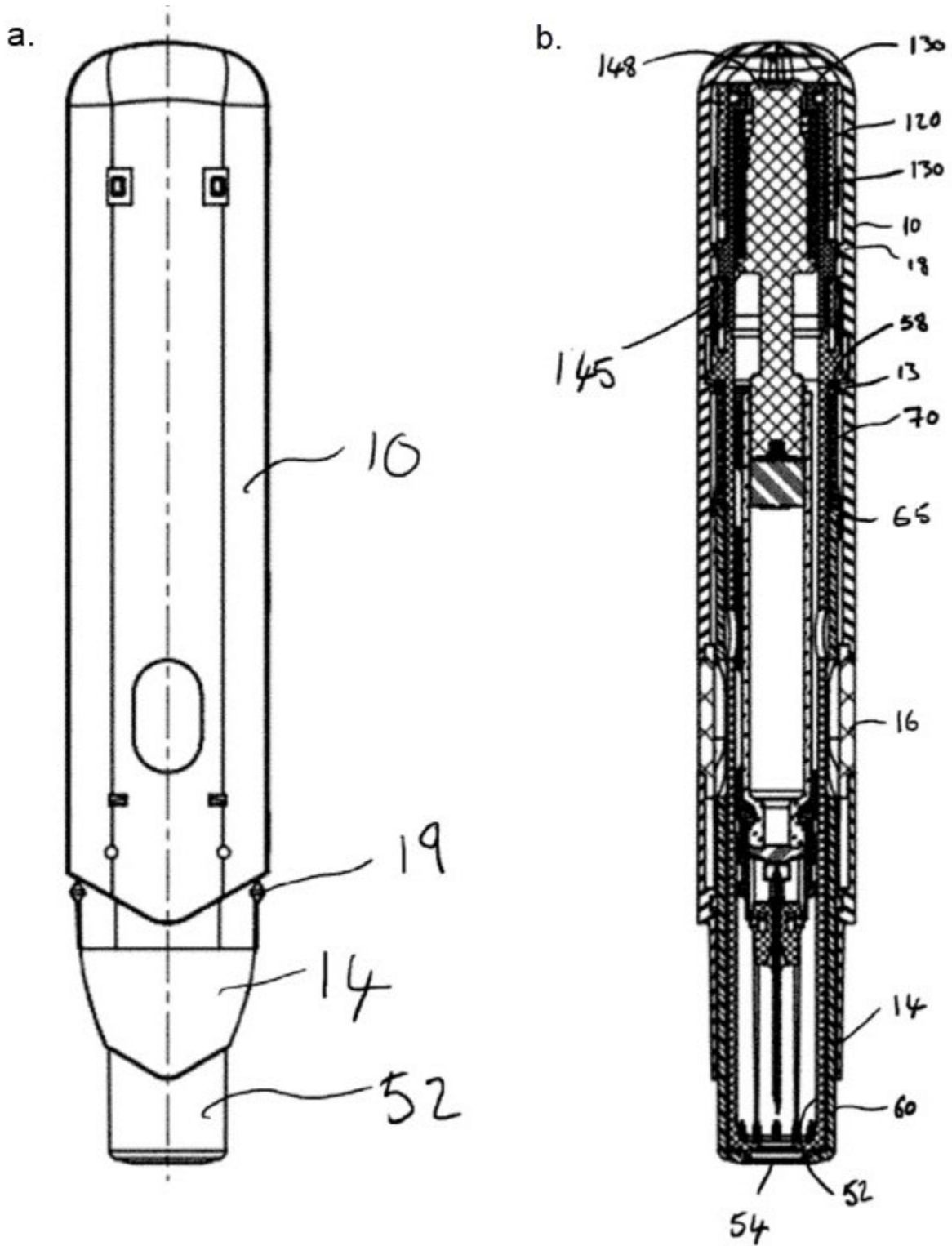

Figure 1 illustrates a motorised handheld injector.

2.



DATE: AUGUST 1, 2026

PROJECT RP11946

Figure 2 illustrates an injector with an actuation mechanism driven by a spring (120).

Relationships with other classification places

Group [A61M 5/20](#) is directed to actuation related aspects and is usually allocated together with groups [A61M 5/24](#) or [A61M 5/28](#).

Group [A61M 5/24](#) and its subgroups relate to cartridge or container aspects of a syringe or injector.

Group [A61M 5/28](#) relates to ampoule specific features.

References

Limiting references

This place does not cover:

Pressure infusion, e.g. using pumps	A61M 5/142
-------------------------------------	----------------------------

Informative references

Attention is drawn to the following places, which might be of interest for search:

Devices for bringing media into the body having means for controlling depth of insertion	A61M 5/46
Hypodermic projectiles	F42B 12/54

A61M 2005/2013

Definition statement

This place covers:

Injectors in which discharging is triggered by pushing the injector against the injection site. No further user action is required.

Illustrative example of subject matter classified in this place:

DATE: AUGUST 1, 2026

PROJECT RP11946

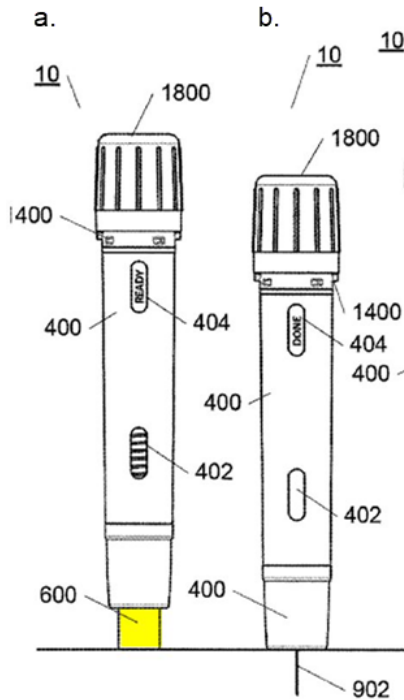

Special rules of classification

If a further user action in addition to pushing injector against the injection site is required in order to dispense the drug (e.g. actuation of a trigger button), group [A61M 2005/208](#) should also be allocated.

[A61M 2005/202](#)

Definition statement

This place covers:

Means to retain drive means of the syringe or injector in a biased (cocked) position, provided either in the device or being attachable to the device.

Illustrative example of subject matter classified in this place:

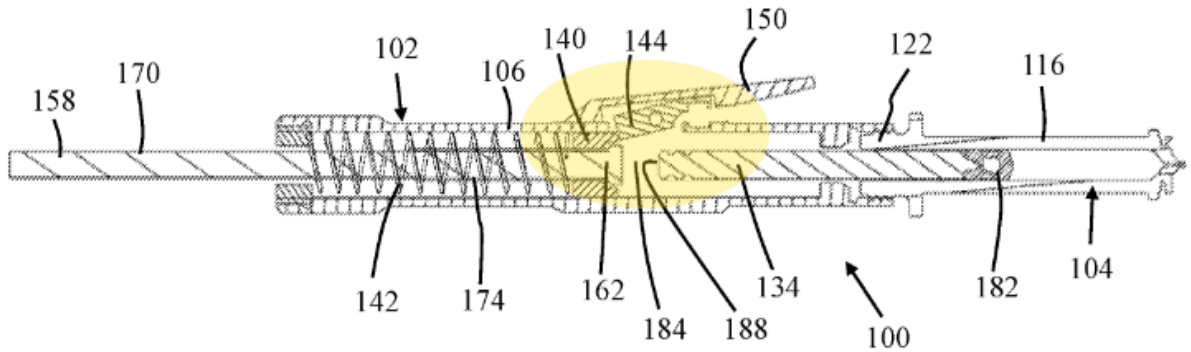

A61M 2005/2026

Definition statement

This place covers:

Syringes or injectors in which the drive element (plunger) is not solely triggered, but manually advanced while receiving a supporting force by a drive means (such as a spring). The required actuation force is thus reduced, e.g. to aid users with reduced dexterity.

Illustrative example of subject matter classified in this place:

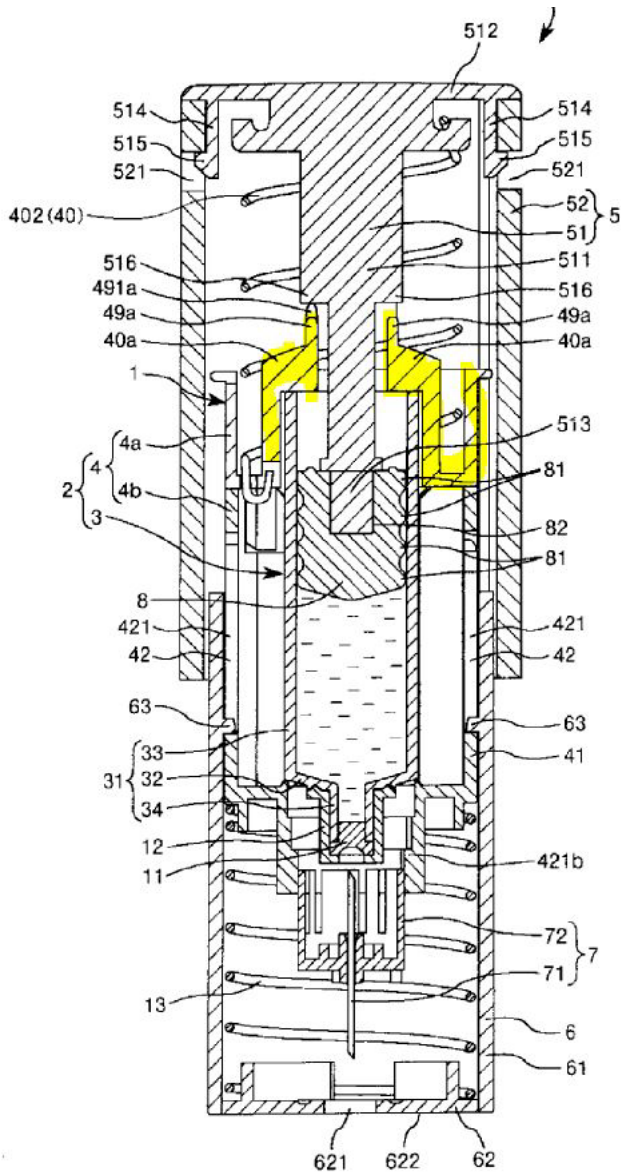

Relationship with other classification places

Syringes or injectors which fully provide the dispensing force are classified in group [A61M 5/2033](#).

A61M 5/2033

Definition statement

This place covers:

Syringes or injectors with a biasing means (usually spring) to fully provide the dispensing force. The user only triggers (i.e. releases) the biased drive means without providing additional (manual) force.

Illustrative example of subject matter classified in this place:

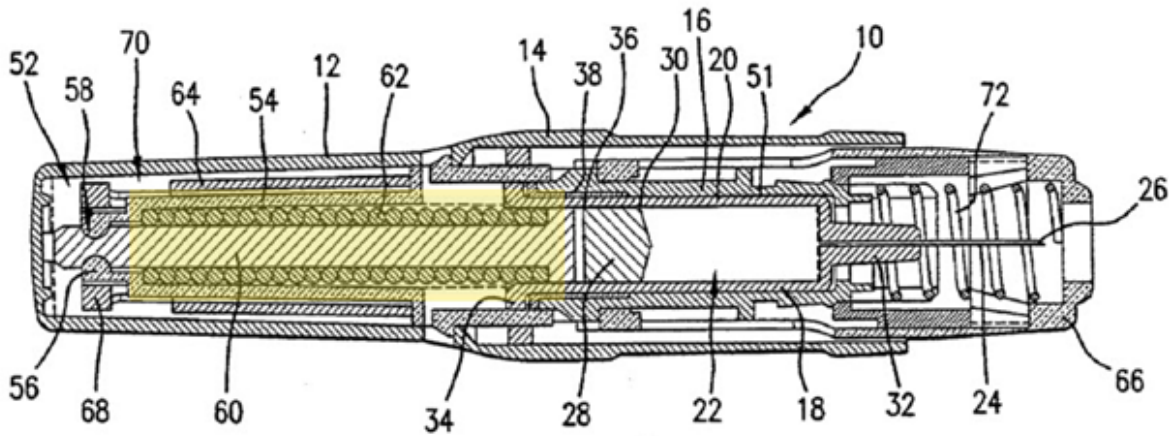

Relationship with other classification places

Syringes or injectors in which the drive element (plunger) is not solely triggered, but manually advanced while receiving a supporting force by a drive means (such as a spring) are classified in group [A61M 2005/2026](#).

A61M 5/2046

Definition statement

This place covers:

Syringes or injectors in which the driving force for expelling the drug (e.g. the force for driving a plunger) is caused by a generation of gas resulting from a chemical reaction, e.g. by an explosive charge of a liquid or solid substance which when ignited is instantaneously vaporised causing an instant volume expansion.

Relationship with other classification places

Syringes or injectors in which the driving force for expelling the drug (e.g. the force for driving a plunger) is conveyed by a pressurised fluid (a gas or a liquid) provided within or fed to the injector, are classified in group [A61M 5/2053](#).

A61M 5/2053

Definition statement

This place covers:

Syringes or injectors in which the driving force for expelling the drug (e.g. the force for driving a plunger) is conveyed by a pressurised fluid (a gas or a liquid) provided within or fed to the injector.

Illustrative examples of subject matter classified in this place:

1a.

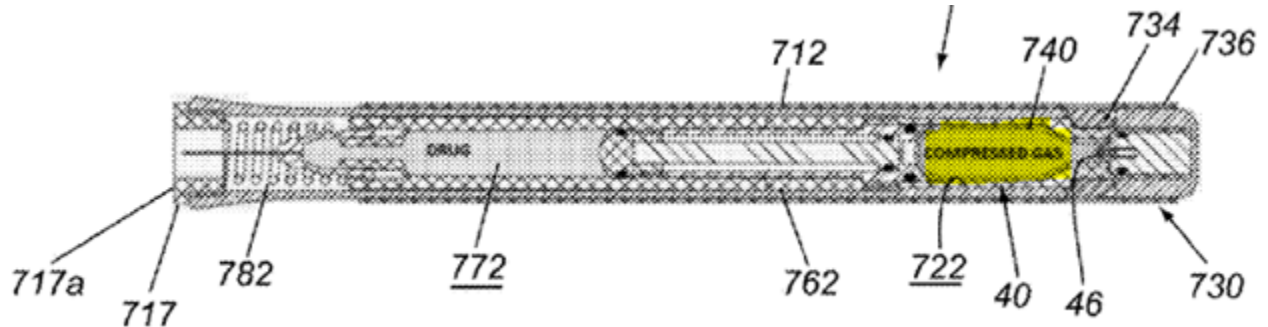

1b.

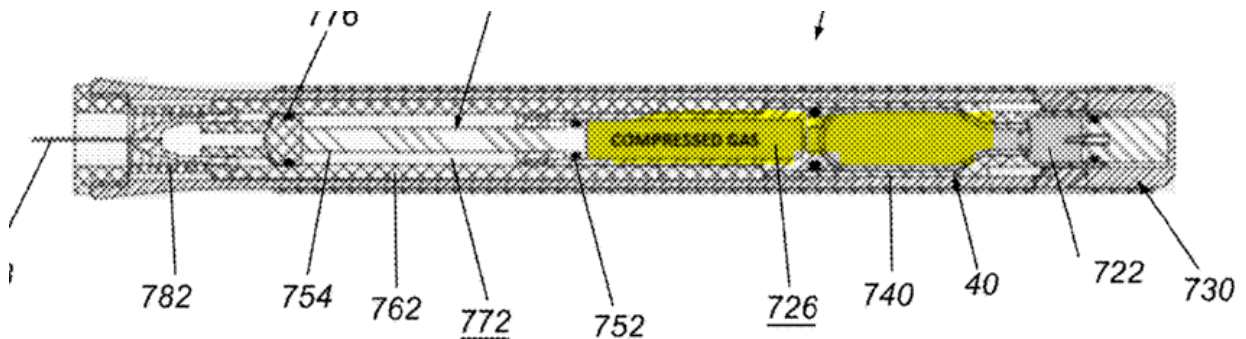

DATE: AUGUST 1, 2026

PROJECT RP11946

2.

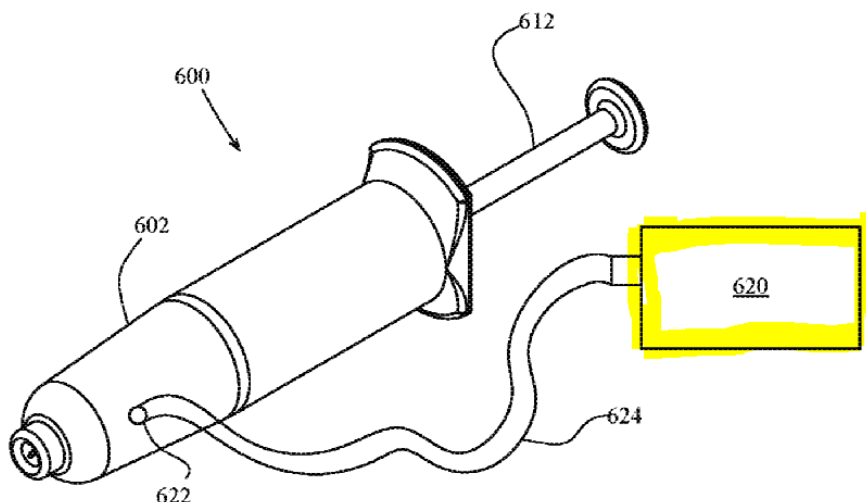

Relationship with other classification places

Syringes or injectors in which the driving force for expelling the drug (e.g. the force for driving a plunger) is caused by a generation of gas resulting from a chemical reaction, e.g. by an explosive charge of a liquid or solid substance, which when ignited is instantaneously vaporised causing an instant volume expansion, are classified in group [A61M 5/2046](#).

Glossary of terms

In this place, the following terms or expressions are used with the meaning indicated:

suction	the plunger is sucked in the distal direction by negative pressure
positive expansion	a chamber in the syringe or injector contains a compressed fluid (typically a gas), which is allowed to expand (analogous to a driving spring) upon triggering (release), i.e. when the chamber is opened

DATE: AUGUST 1, 2026

PROJECT RP11946

fluid feed	the syringe or injector is connected to a (pressurised) fluid line. The actuation force being provided by the (pressurised) fluid.
------------	--

A61M 5/206**Definition statement***This place covers:*

Automatic needle inserters which move the needle in relation to the body of the injection device.

References***Informative references****Attention is drawn to the following places, which might be of interest for search:*

Biased sleeves where the needle is uncovered by insertion of the needle into a patient's body	A61M 2005/3267
---	--------------------------------

A61M 5/2066**Definition statement***This place covers:*

Automatic syringes or injectors (e.g. epinephrine autoinjectors) for injecting two or more media (drugs, flushing agents, solvents) either sequentially or as mixture.

References***Informative references****Attention is drawn to the following places, which may be of interest for search:*

Ampoule syringes comprising means for injection of two or more media, e.g. by mixing	A61M 5/2448
--	-----------------------------

Syringe ampoules or carpules comprising means for injection of two or more media, e.g. by mixing

A61M 5/284

Special rules of classification

If the piston (or piston rod) comprises means for mixing of the two or more substances, group A61M 5/31596 should also be allocated.

If a needle or cannula comprises means for mixing two or more substances, group A61M 5/3294 should also be allocated.

A61M 2005/208

Definition statement

This place covers:

Syringes or injectors in which the trigger (e.g. firing button) is initially blocked and only released by pushing the injector against the injection site.

The dispensing, however, does not happen automatically but has to be triggered by the user (e.g. pressing a firing button).

Illustrative example of subject matter classified in this place:

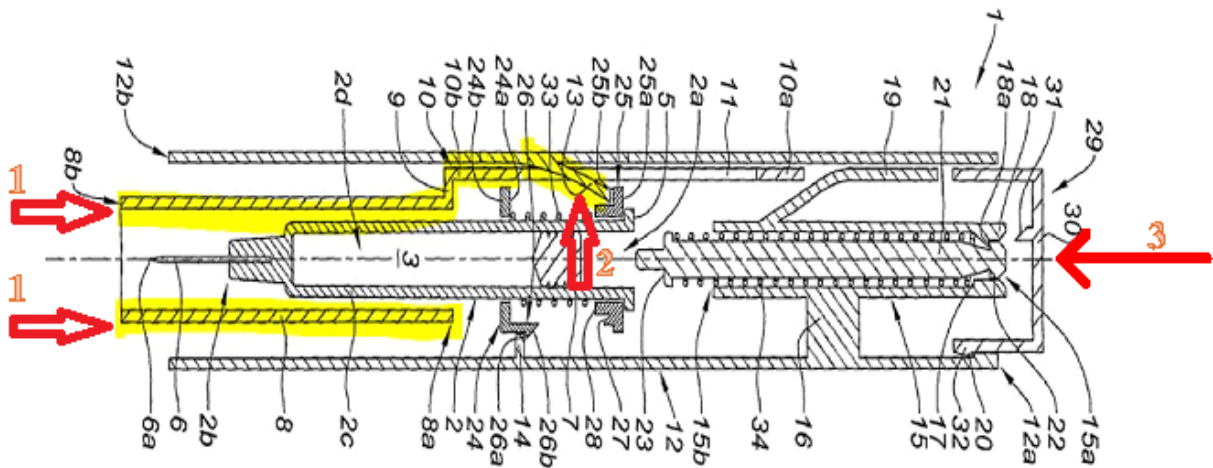

A61M 5/24

Definition statement

This place covers:

Syringes or injectors with a replaceable cartridge.

Relationship with other classification places

Group [A61M 5/24](#) and its subgroups relate to cartridge or container aspects of a syringe or injector. Actuation-related aspects should be classified in group [A61M 5/20](#).

References

Informative references

Attention is drawn to the following places, which might be of interest for search:

Ampoules or carpules	A61J 1/06
----------------------	---------------------------

A61M 5/2448

Definition statement

This place covers:

Syringes or injectors with one or more replaceable cartridges for injecting two (or more) media (drugs, flushing agents, solvents) either sequentially or by mixing.

Illustrative example of subject matter classified in this place:

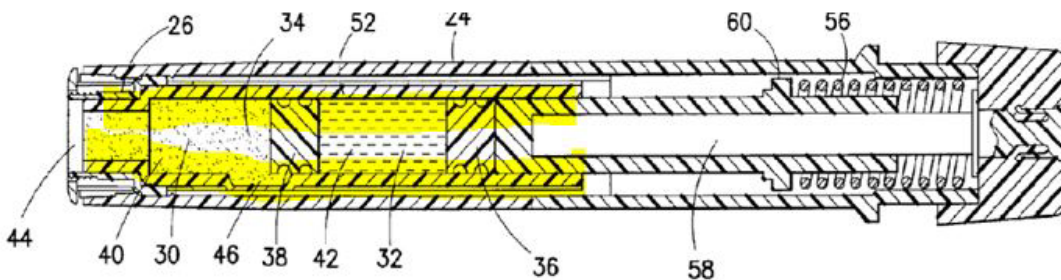

DATE: AUGUST 1, 2026

PROJECT RP11946

References**Informative references**

Attention is drawn to the following places, which may be of interest for search:

Automatic syringes comprising means for injection of two or more media, e.g. by mixing	A61M 5/2066
Syringe ampoules or carpules comprising means for injection of two or more media, e.g. by mixing	A61M 5/284

Special rules of classification

If the piston (or piston rod) comprises means for mixing of the two or more substances, group [A61M 5/31596](#) should also be allocated.

If a needle or cannula comprises means for mixing two or more substances, group [A61M 5/3294](#) should also be allocated.

A61M 5/28**Definition statement**

This place covers:

Drug containers (such as cartridges or ampoules) which comprise a (non-detachable) needle, as well as injectors comprising such a syringe ampoule.

Illustrative example of subject matter classified in this place:

DATE: AUGUST 1, 2026

PROJECT RP11946

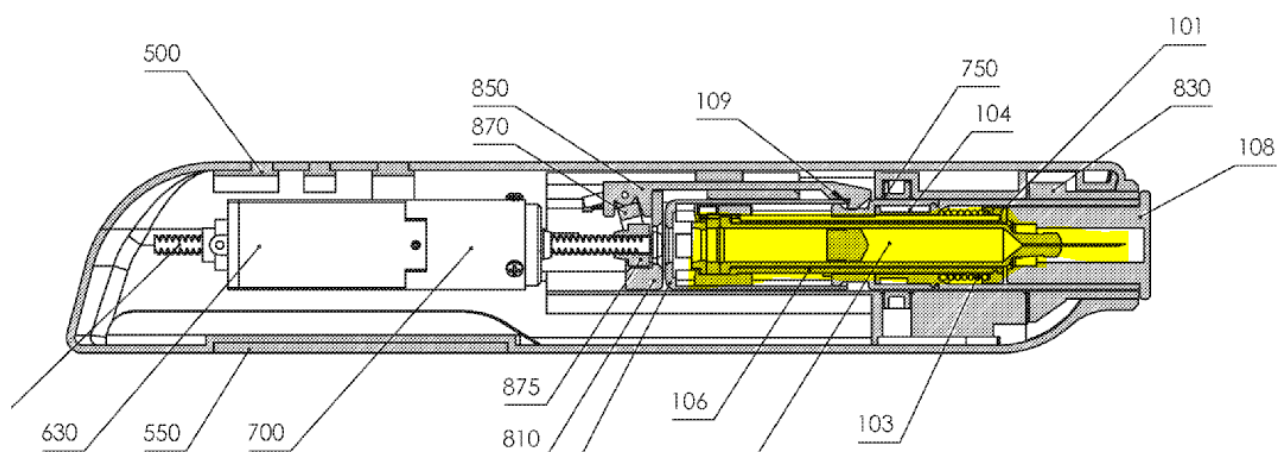

Relationship with other classification places

This group and its subgroups relate to ampoule specific features. For automatic injectors comprising such syringe ampoules, group [A61M 5/20](#) and its subgroups are allocated for actuation-related features.

A61M 5/284

Definition statement

This place covers:

Syringe ampoules for injecting two (or more) media (e.g. drugs, flushing agents, solvents) either sequentially or by mixing.

References

Informative references

Attention is drawn to the following places, which might be of interest for search:

Automatic syringes comprising means for injection of two or more media, e.g. by mixing	A61M 5/2066
Ampoule syringes comprising means for injection of two or more media, e.g. by mixing	A61M 5/2448

DATE: AUGUST 1, 2026

PROJECT RP11946

Special rules of classification

If the piston (or piston rod) comprises means for mixing two or more substances, group [A61M 5/31596](#) should also be allocated.

If a needle or cannula comprises means for mixing two or more substances, group [A61M 5/3294](#) should also be allocated.

A61M 2005/3022

Definition statement

This place covers:

Syringes or injectors that can be carried on the user's body, e.g. by means of straps or a patch.

Relationships with other classification places

Syringes or injectors classified here are used for a single (emergency) injection or for multiple, separate single-injection shots, each shot triggered by a user. In contrast, skin patch-type pumps, group [A61M 5/14248](#), cover the details of the dosage delivery and the timing thereof over a longer period of time and autonomously manage dosing regimen.

References

Informative references

Attention is drawn to the following places, which might be of interest for search:

Pressure infusion of the skin patch type, e.g. using pumps	A61M 5/14248
--	------------------------------

A61M 2005/3103

Definition statement

This place covers:

Devices for preventing leakage, i.e. spilling of the liquid drug, from the distal end of the syringe, such as caps or plugs.

Illustrative example of subject matter classified in this place:

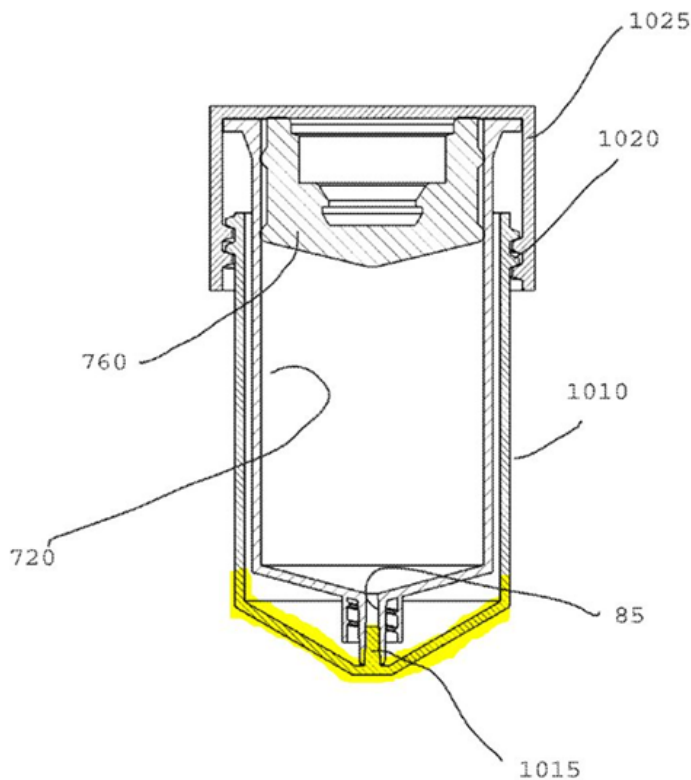

DATE: AUGUST 1, 2026

PROJECT RP11946

References

Informative references

Attention is drawn to the following places, which might be of interest for search:

Means preventing contamination of the medicament compartment of a syringe	A61M 2005/3117
---	--------------------------------

A61M 2005/3117

Definition statement

This place covers:

Devices or arrangements for preventing the content of a syringe from becoming contaminated and which extend beyond merely sealing the syringe compartment. Examples are filters or caps comprising a disinfectant.

Relationship with other classification places

Means for simply sealing the distal end of the syringe without any other contamination prevention should only be classified in group [A61M 2005/3103](#).

Informative references

Attention is drawn to the following places, which might be of interest for search:

Leak prevention means for the distal end of the syringe	A61M 2005/3103
---	--------------------------------

A61M 2005/3131

Definition statement

This place covers:

Syringe barrels having special means or properties in order to improve sliding of the piston, such as coatings (e.g. silicon oil) or barrel materials that exhibit specific surface properties (e.g. a specific roughness).

A61M 5/3135

Definition statement

This place covers:

Syringes with special features at its plunger receiving end. Examples are plunger engaging radial protrusions or specific proximal internal barrel shape.

Illustrative example of subject matter classified in this place:

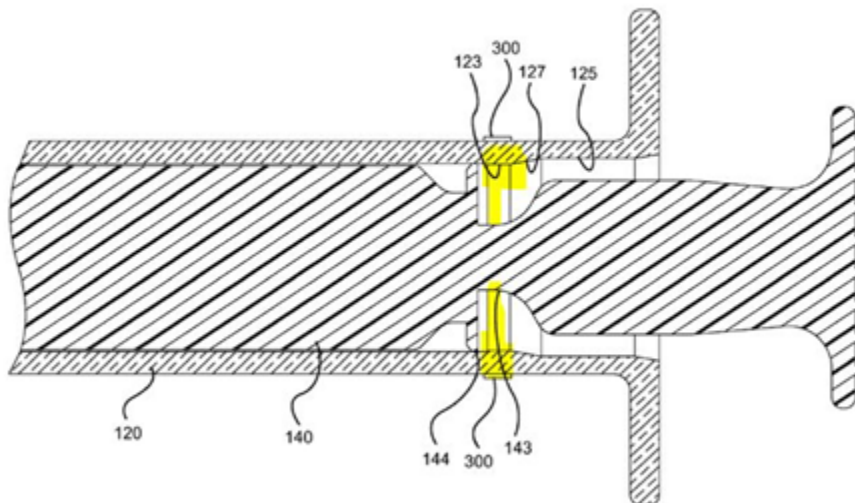

DATE: AUGUST 1, 2026

PROJECT RP11946

Relationship with other classification places

Specially designed finger grips (usually also on the proximal end of a syringe) are classified under group [A61M 5/3137](#).

A61M 5/3137

Definition statement

This place covers:

Features relating to the finger grip means of the syringe barrel, independent of whether said finger grip means is positioned on the distal or the proximal end of the syringe barrel.

A61M 5/3153

Definition statement

This place covers:

Injectors which might be equipped with a dial for setting a dose or not, but which are limited to deliver only a single stroke. No further stroke or injection can be performed once a first injection shot has been done.

A61M 5/31578

Definition statement

This place covers:

Drive mechanisms for driving the plunger rod into the drug container with an axially moving drive element directly contacting the plunger rod.

DATE: AUGUST 1, 2026

PROJECT RP11946

A61M 5/31583

Definition statement

This place covers:

Drive mechanisms for driving the piston rod into the drug container with a rotationally moving drive element directly contacting the piston rod (e.g. the piston rod being driven by worm or rack and pinion gear).

A61M 5/31585

Definition statement

This place covers:

Actuators moving axially, i.e. in line with or parallel to the longitudinal axis of the injector and the piston rod.

A61M 5/31586

Definition statement

This place covers:

Pivoting or rotating actuators, i.e. actuators moving in a circular way with respect to the injector.

A61M 5/32

Definition statement

This place covers:

Needles and specific needle accessories for use with syringes or injection devices. Needle accessories are devices or arrangements for providing needle related functions, such as needle shields, needle caps, needle shield removers, needle inserters.

Subgroups also relate to constructional features of the needle tip, the needle shaft and of the connection between needle and needle hub.

DATE: AUGUST 1, 2026

PROJECT RP11946

References**Limiting references***This place does not cover:*

Infusion needles	A61M 5/158
------------------	----------------------------

Informative references*Attention is drawn to the following places, which may be of interest for search:*

Apparatus for cleaning or sterilising needles	A61M 5/001
Devices for bringing media into the body having means for desensitising or protruding skin	A61M 5/42
Devices for bringing media into the body having means for controlling depth of insertion	A61M 5/46
Guide needles for catheters	A61M 25/065
Manufacture of syringes or needles	B29L 2031/7544

A61M 5/3202**Definition statement***This place covers:*

Devices for covering a needle prior to its designated use, such as caps being removed from the needle before use and discarded.

References**Limiting references***This place does not cover:*

Protectors for infusion spikes	A61M 5/1626
Means for protection against accidental injuries of used needles	A61M 5/321
Protectors for sharps	A61B 50/3001

DATE: AUGUST 1, 2026

PROJECT RP11946

Informative references

Attention is drawn to the following places, which may be of interest for search:

Protectors for infusion spikes	A61M 5/1626
--------------------------------	-----------------------------

A61M 5/32023

Definition statement

This place covers:

Devices (e.g. caps) having a secondary function besides merely protecting the needle.

Examples of such a secondary function are:

- Sealing the needle lumen to avoid spilling;
- Blocking injector activation by preventing movement of a needle shield; or
- Having additional sensing means, such as a temperature sensor.

A61M 5/321

Definition statement

This place covers:

Devices or arrangements for protecting a user from contacting a used needle, i.e. to prevent infection of the user through needle pricking.

Exemplary devices or arrangements are axially extensible needle covers, or caps that are placed over the needle after its use.

Informative references

Attention is drawn to the following places, which may be of interest for search:

Devices for protection of the needle before use, e.g. caps	A61M 5/3202
--	-----------------------------

A61M 2005/3253

Definition statement

This place covers:

Protective sleeves, i.e. needle shields, coaxially slidable on the syringe barrel with a special safety feature (that prevents re-use of the syringe or injector). When the protective sleeve is removed from the syringe barrel, e.g. by pulling the sleeve off the barrel distally or by snapping it off the syringe barrel by bending, it takes the needle hub and the needle with it, i.e. it disconnects the needle hub from the syringe barrel.

Illustrative examples of subject matter classified in this place:

1a.

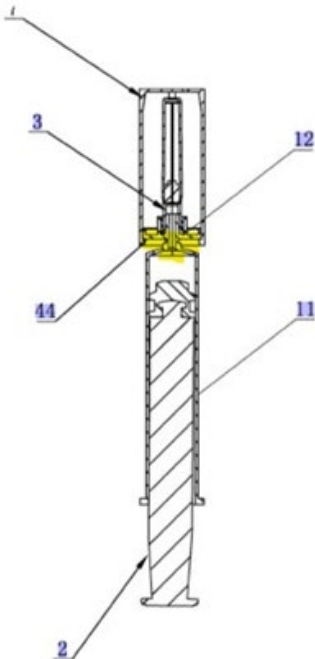

1b.

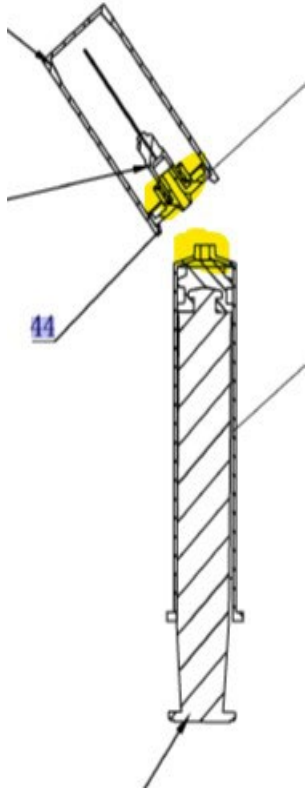

2a.

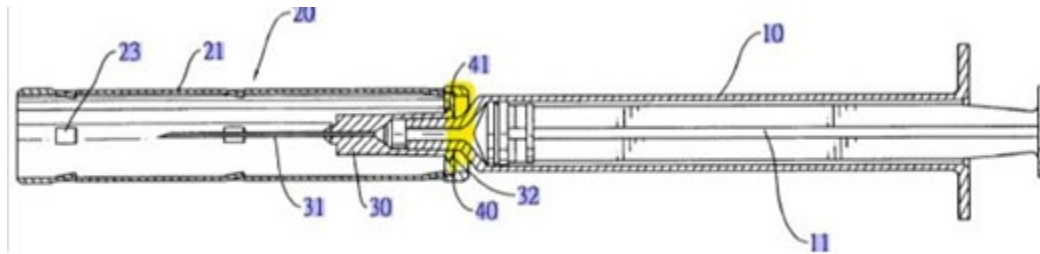

2b.

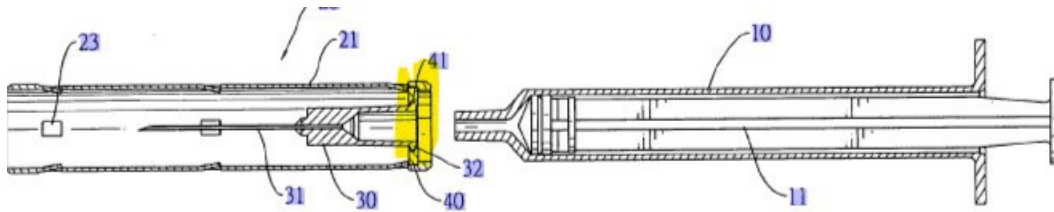

DATE: AUGUST 1, 2026

PROJECT RP11946

A61M 5/3257

Definition statement

This place covers:

Protective needle sleeves that require a deliberate user action to extend after injector use (in contrast to a fully automatic sleeve extension upon removal).

References

Informative references

Attention is drawn to the following places, which may be of interest for search:

Fully automatic sleeve extension	A61M 5/326
----------------------------------	----------------------------

A61M 5/326

Definition statement

This place covers:

Protective needle sleeves extending automatically and without any specific user interaction upon removal of the syringe or injector from the injection site.

References

Informative references

Attention is drawn to the following places, which may be of interest for search:

Semi-automatic sleeve extension	A61M 5/3257
---------------------------------	-----------------------------

A61M 2005/3267

Definition statement

This place covers:

DATE: AUGUST 1, 2026

PROJECT RP11946

Protective needle sleeves that are biased in axial direction (usually by means of a spring) toward the needle covering position.

A61M 5/3287

Definition statement

This place covers:

Accessories helping the user to insert the needle more easily or more accurately.

References

Limiting references

This place does not cover:

Automatic syringes, e.g. with automatically actuated piston rod, with automatic needle injection, filling automatically	A61M 5/20
Guiding the movement of the rod or piston; Appliances on the pistons or piston-rods for facilitating dosing	A61M 5/31525

A61M 5/422

Definition statement

This place covers:

Desensitising the skin, e.g. by cooling the skin or by applying an analgesic in order to reduce algesia or sensitivity.

A61M 2039/0009

Definition statement

This place covers:

Components or sets comprising components such as tubes, connectors, valves, access sites and the like with a specific functionality (examples of this functionality are defined in the subgroups).

Illustrative example of subject matter classified in this place:

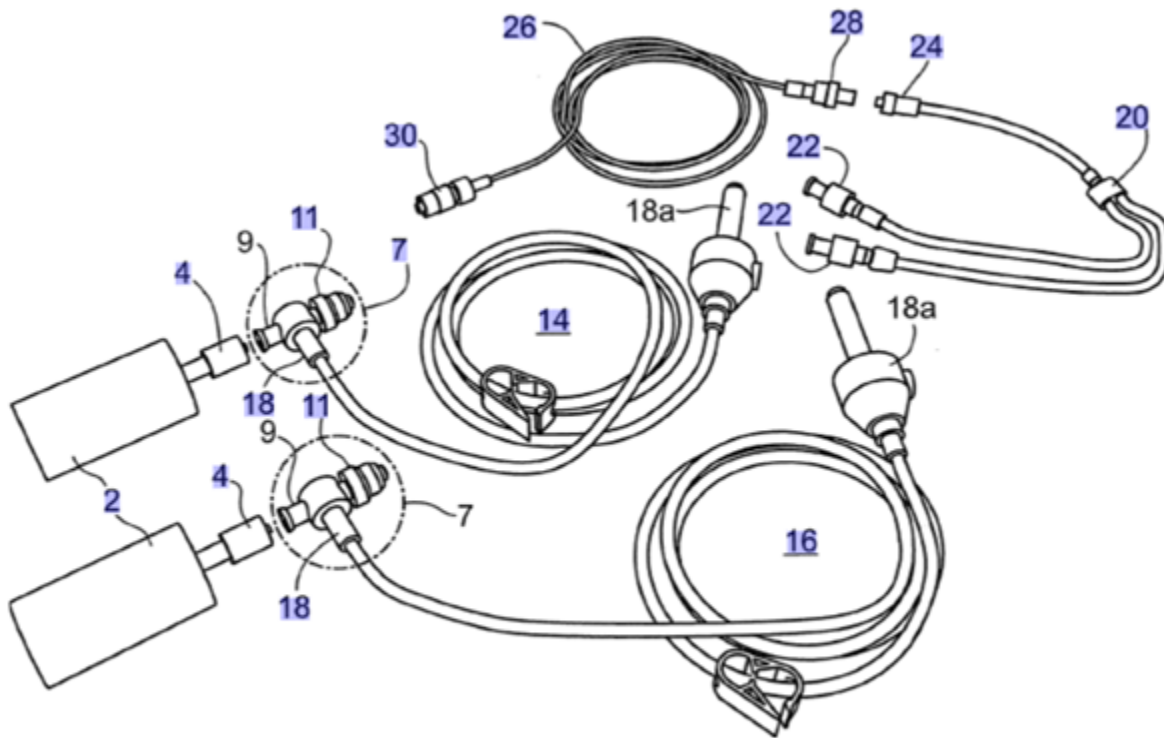

References

Informative references

Attention is drawn to the following places, which may be of interest for search:

Devices for bringing media into the body, for contrast media	A61M 5/007
Infusion of two or more substances	A61M 5/1407

Modular systems comprising interconnection elements	A61M 5/1413
---	-----------------------------

A61M 2039/0018

Definition statement

This place covers:

Components or sets comprising components such as tubes, connectors, valves, access sites and the like with a specific functionality for or aiding in the flushing of an infusion line.

Illustrative example of subject matter classified in this place:

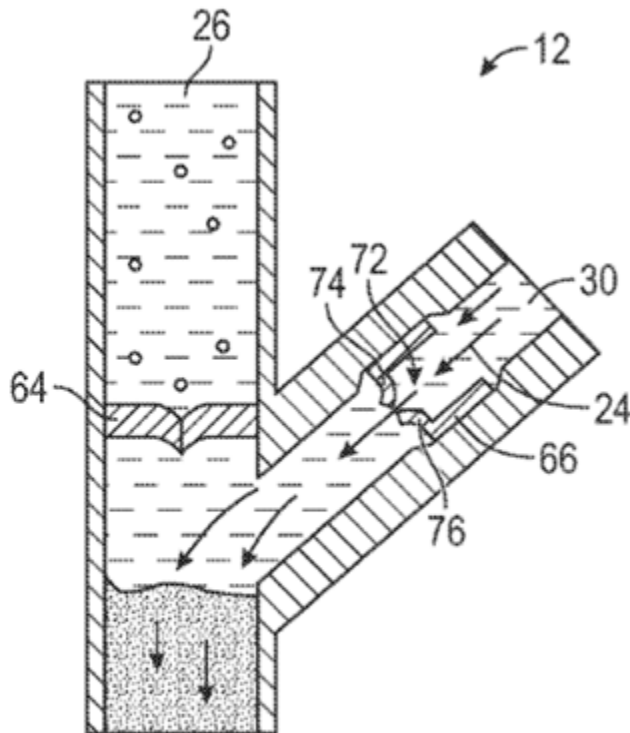

The Figure illustrates a valve arrangement in a Y-connector specifically for flushing (purging) a downstream infusion arrangement.

DATE: AUGUST 1, 2026

PROJECT RP11946

A61M 2039/0027

Definition statement

This place covers:

Components or sets comprising components such as tubes, connectors, valves, access sites and the like with a specific functionality for mixing two or more liquids or solids from different reservoirs.

Illustrative example of subject matter classified in this place:

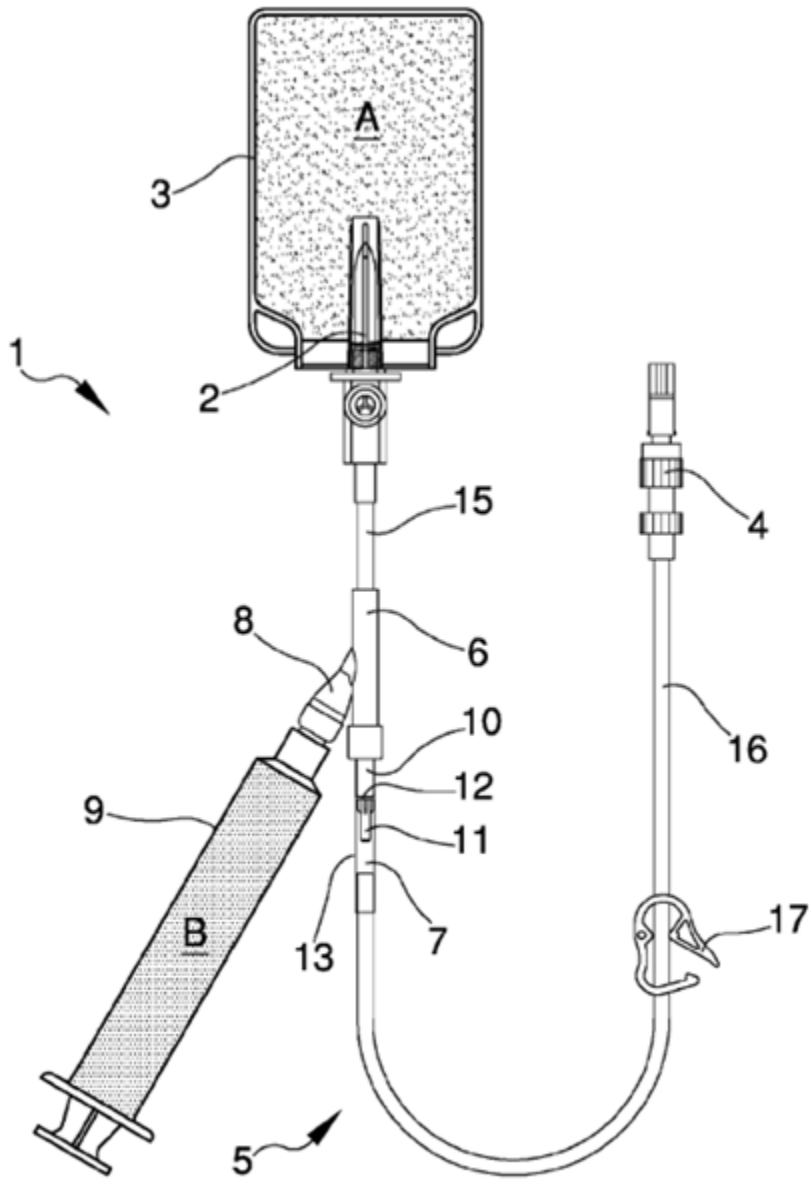

The Figure illustrates a tube set comprising a specific mixing arrangement (10-12) for mixing and administering liquids (A, B).

A61M 2039/0036

Definition statement

This place covers:

The device being provided with a characterising septum, such as providing specific functions, e.g. having venting channels or being made from antimicrobial or self-lubricating elastomer.

A61M 2039/0045

Definition statement

This place covers:

Illustrative example of subject matter classified in this place:

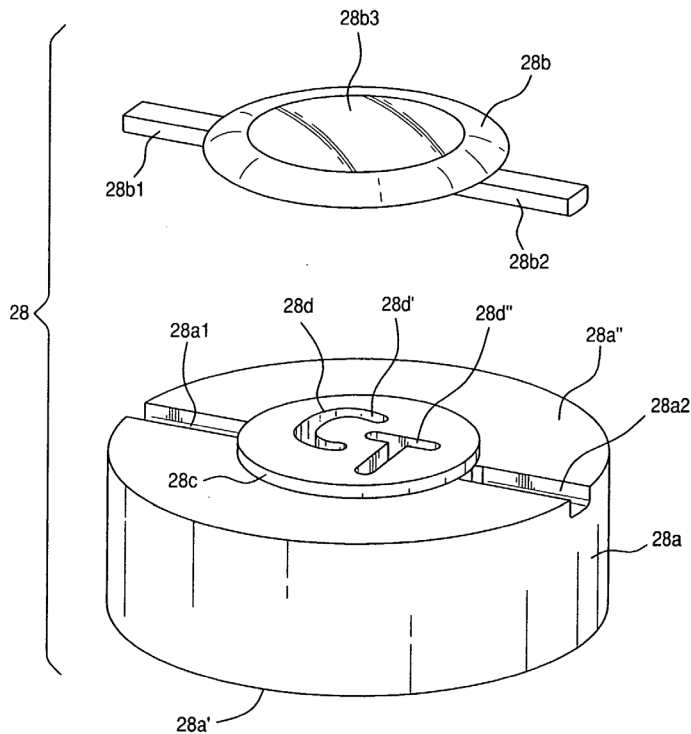

The Figure illustrates a septum or a related part (see insert (28d)) comprising means for absorbing or altering radiation, allowing radiologic detection.

A61M 2039/0063

Definition statement

This place covers:

Any provisions on the septum or the assembly which provide or ensure the alignment (correct position) of the septum in its holder.

Illustrative example of subject matter classified in this place:

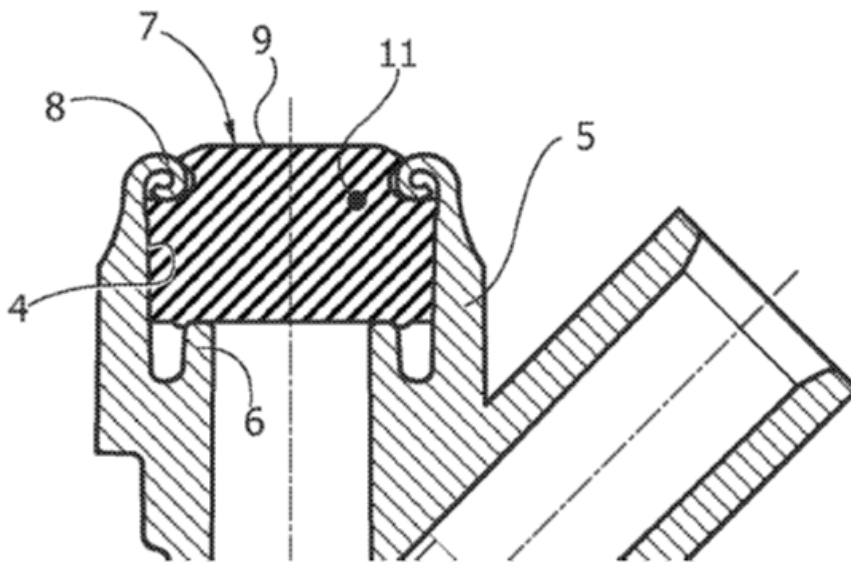

The Figure illustrates septum (7) comprising a circular groove which is engaged by anchors (8) to align the septum in the housing (5).

A61M 2039/0072

Definition statement

This place covers:

Any provisions on the septum or the assembly which provide or ensure tightness of the septum, such as by compressing the septum or limiting its deformation.

Illustrative example of subject matter classified in this place:

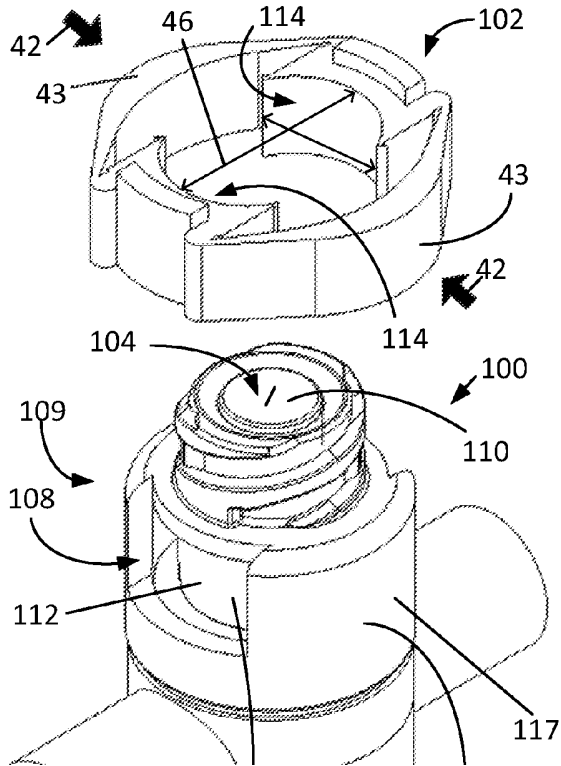

The Figure illustrates a biasing element (102) attached to port (100) to squeeze the septum (110) in order to prevent leakage from septum slit (104).

A61M 2039/0081

Definition statement

Means, such as guiding arrangements, to aid a user in introducing a needle through a septum.

Illustrative example of subject matter classified in this place:

1.

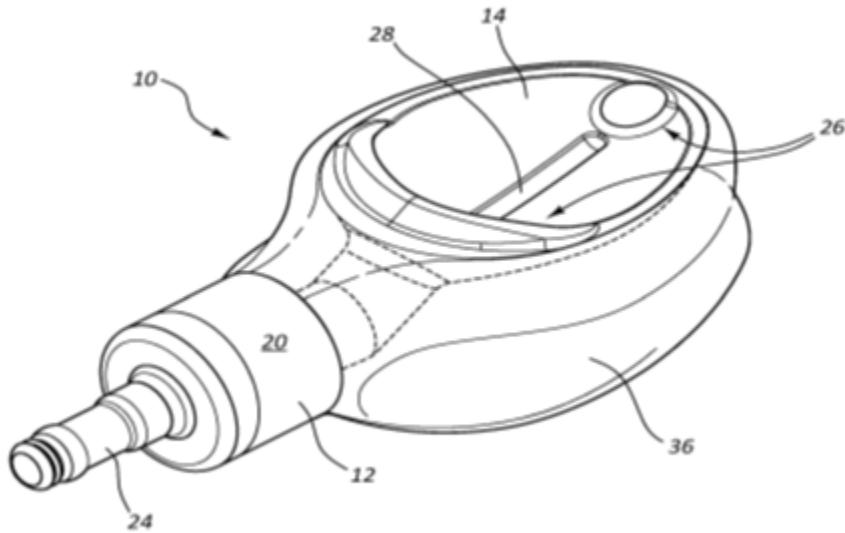
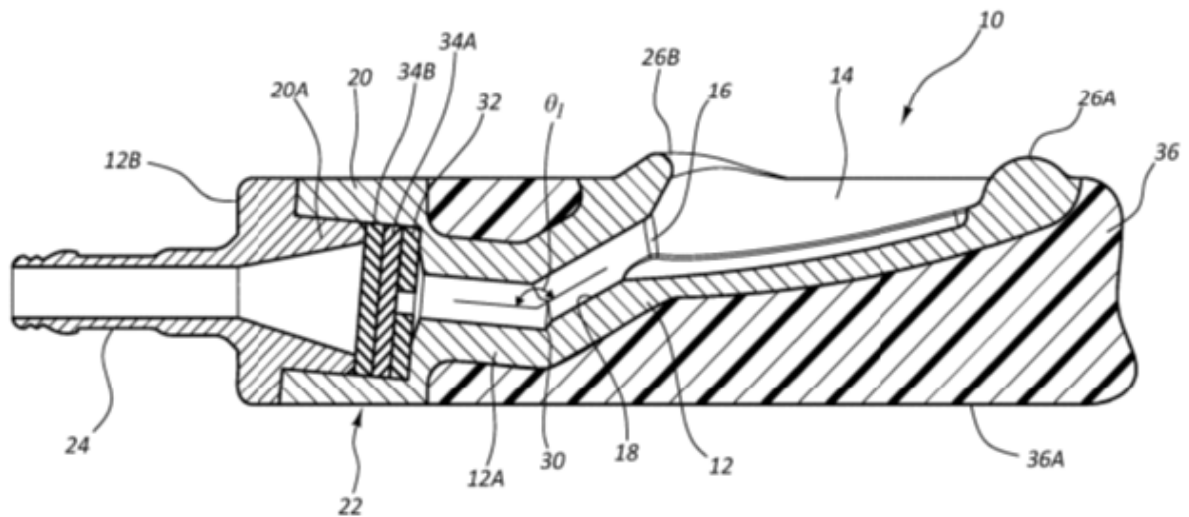

Figure 1 illustrates a needle receiving cup (14) having a needle groove (28) to ensure that the needle is guided to the internal septum (34A, 34B) shown in side view in Figure 2.

2.



A61M 2039/009

Definition statement

Protective means limiting or preventing unintended access to the septum.

Illustrative example of subject matter classified in this place:

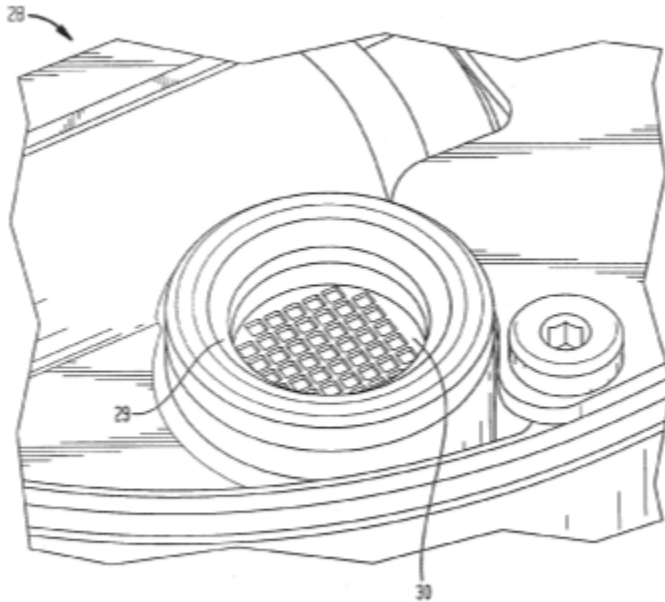

The Figure illustrates grid (30) comprising a plurality of openings to only allow piercing of the septum with needles up to a defined diameter.

A61M 39/02

Definition statement

This place together with its subgroups covers the following types of access sites:

- Subcutaneous ports (i.e. implanted under the skin);
- Transcutaneous ports (i.e. having a part above and below the skin);
- Ports located upstream of or in a fluid line entering the human or animal body, including such ports further comprising a pierceable, self-sealing member; or
- Haemostasis valves comprised within catheters or like devices accessing the vascular system. The haemostasis valve allows insertion of a needle (or similar object) while preventing blood from leaking, when the valve is closed.

References

Informative references

Attention is drawn to the following places, which may be of interest for search:

Needles for infusion	A61M 5/158
Catheters; Hollow probes	A61M 25/00

A61M 39/0208

Definition statement

This place covers:

Devices providing fluidical access to the body and being located underneath the patient's skin.

Illustrative example of subject matter classified in this place:

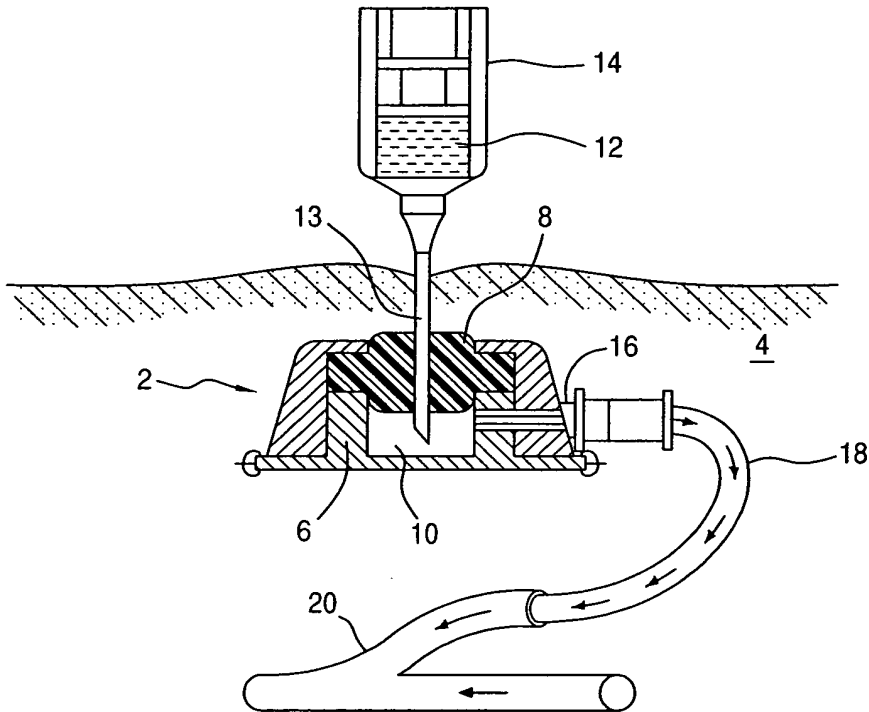

DATE: AUGUST 1, 2026

PROJECT RP11946

References

Limiting references

This place does not cover:

Implantable infusion devices	A61M 5/14276
Transcutaneous or percutaneous access sites to the inside of the body	A61M 39/0247

Informative references

Attention is drawn to the following places, which may be of interest for search:

Infusion devices specially adapted for implantation	A61M 5/14276
Access sited having pierceable self-sealing members	A61M 39/04

A61M 39/0247

Definition statement

This place covers:

Devices providing fluidic access to the body and being partly exterior of the patient's skin and in part inside the patient's body, i.e. the device is not completely covered by tissue.

Illustrative example of subject matter classified in this place:

DATE: AUGUST 1, 2026

PROJECT RP11946

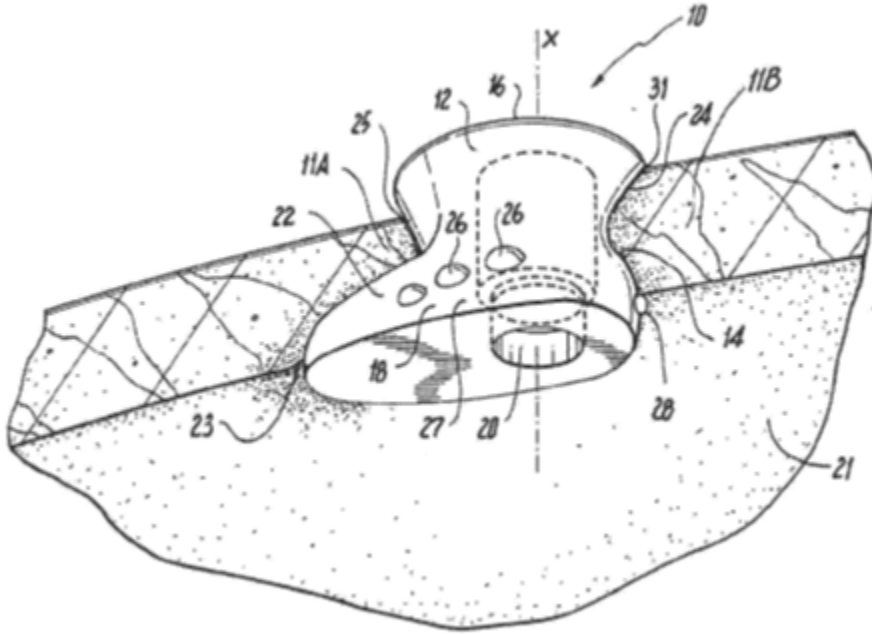

References

Informative references

Attention is drawn to the following places, which may be of interest for search:

Peritoneal dialysis catheters	A61M 1/285
Tracheostomy devices	A61M 16/0465
Access sited having pierceable self-sealing members	A61M 39/04
Measuring pressure within the body	A61B 5/03
Colostomy devices	A61F 5/445
Gastrostomy feeding tubes	A61J 15/0015
Means for fixing a feeding tube outside the body	A61J 15/0053

DATE: AUGUST 1, 2026

PROJECT RP11946

A61M 39/04**Definition statement***This place covers:*

Fluid ports located upstream of or in a fluid line entering the human or animal body, and which normally comprise a pierceable, self-sealing member.

These access sites should not be confused with (male or female) connectors comprising a (pierceable) self-sealing member, which is opened (or pierced) by a respective connector counterpart.

Illustrative example of subject matter classified in this place:

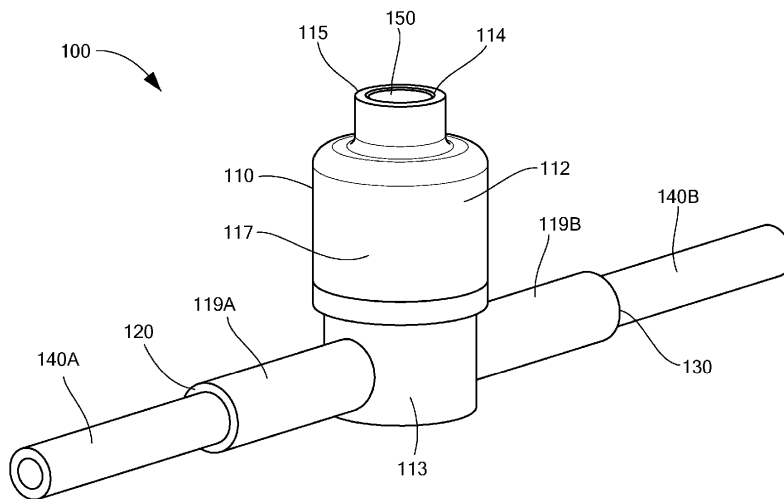

The Figure illustrates a device (100) that provides access to an infusion line (140A, 140B) by a self-sealing member, e.g. by a septum (150) which is pierceable by a needle and seals the access site again when the needle is removed.

References**Informative references**

Attention is drawn to the following places, which may be of interest for search:

Subcutaneous access sites for injecting or removing fluids	A61M 39/0208
--	------------------------------

Transcutaneous or percutaneous access sites to the inside of the body	A61M 39/0247
Multi-channel connectors or couplings	A61M 39/105
Connectors comprising valves	A61M 39/26

A61M 39/045

Definition statement

This place covers:

The septum comprises a slit, which can be penetrated by a blunt and hollow component, such as a cannula (but not a connector counterpart, see below).

These access sites should not be confused with (male or female) connectors comprising a (pierceable) self-sealing member, which is opened (or pierced) by a respective connector counterpart.

Illustrative example of subject matter classified in this place:

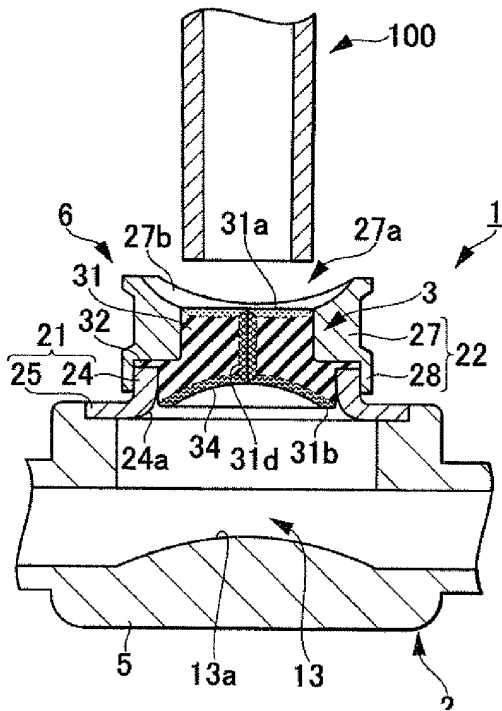

DATE: AUGUST 1, 2026

PROJECT RP11946

The Figure illustrates a tube (100) that presses the pre-slit septum (31) into the open position in order to inject a fluid in the space (13). The tube (100) is not permanently connected to the port as it would be the case for connectors comprising valves.

A61M 39/06

Definition statement

This place covers:

Details of haemostasis valves (and not necessarily the surrounding valve assembly).

Haemostasis valves close and seal around a needle, a catheter or a similar object to prevent blood leakage from a vessel, for example, during minimally invasive heart surgeries.

A61M 39/0606

Definition statement

This place covers:

Haemostasis valves without dedicated means to set or alter the sealing pressure or opening characteristics of the valve.

References

Limiting references

This place does not cover:

Access sites including means for seal penetration

A61M 39/0693

A61M 39/0613

Definition statement

This place covers:

Haemostasis valves comprising dedicated means to set or alter the sealing pressure or opening characteristics of the valve.

Illustrative example of subject matter classified in this place:

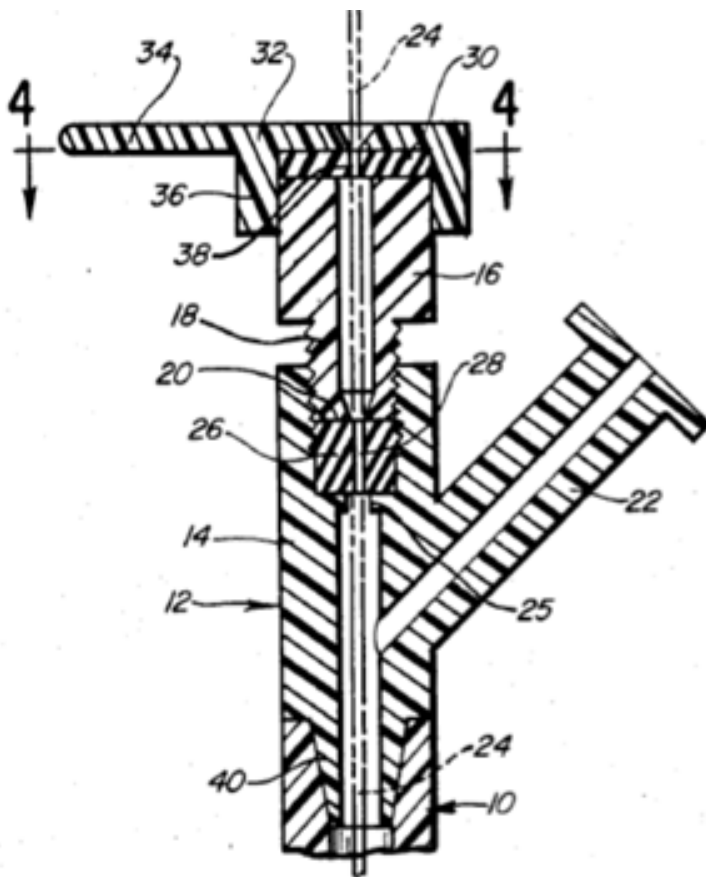

The Figure illustrates a haemostasis gasket (26) that can be deformed via threaded element (16) in order to manipulate the valve characteristics (i.e. sealing pressure).

DATE: AUGUST 1, 2026

PROJECT RP11946

References

Limiting references

This place does not cover:

Access sites including means for seal penetration	A61M 39/0693
---	------------------------------

A61M 2039/0633

Definition statement

This place covers:

The haemostasis valve being made of resiliently deformable material, thus providing an inherent sealing force.

If the valve does not comprise an opening, it will be pierced by the introduced needle, catheter or the like.

A61M 2039/064

Definition statement

This place covers:

The valve comprises a slit through which a catheter, cannula or the like is introduced.

Illustrative example of subject matter classified in this place:

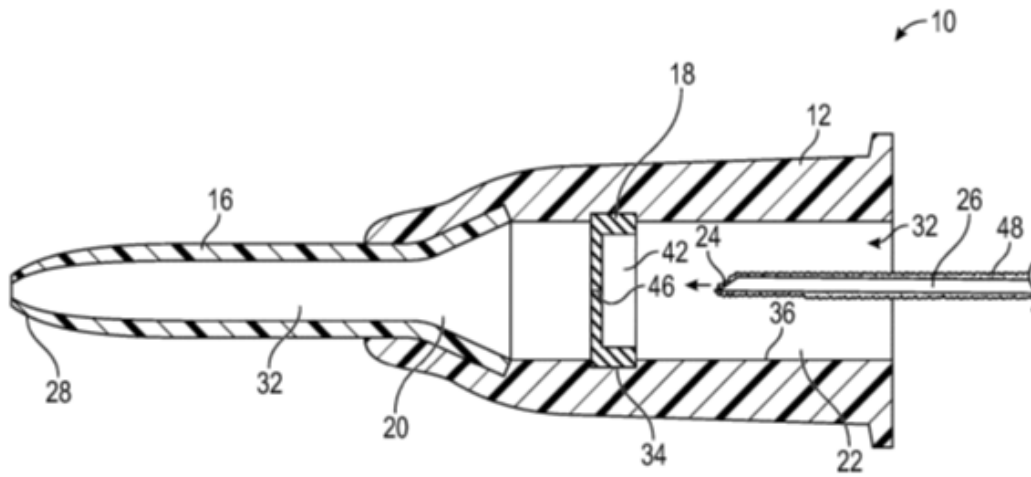

The Figure illustrates a valve (34) comprising a slit (46).

A61M 2039/0646

Definition statement

This place covers:

Duckbill valves have the shape and open like a "duck's mouth".

Illustrative example of subject matter classified in this place:

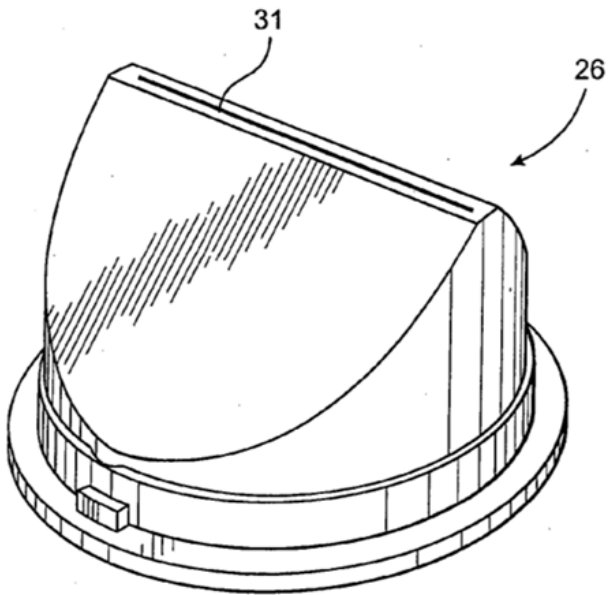

The Figure illustrates a duckbill-valve (26) with a slit (31).

A61M 2039/0653

Definition statement

This place covers:

Disc (or disc-like) element with holes or openings acting or contributing to the valve functionality.

Illustrative example of subject matter classified in this place:

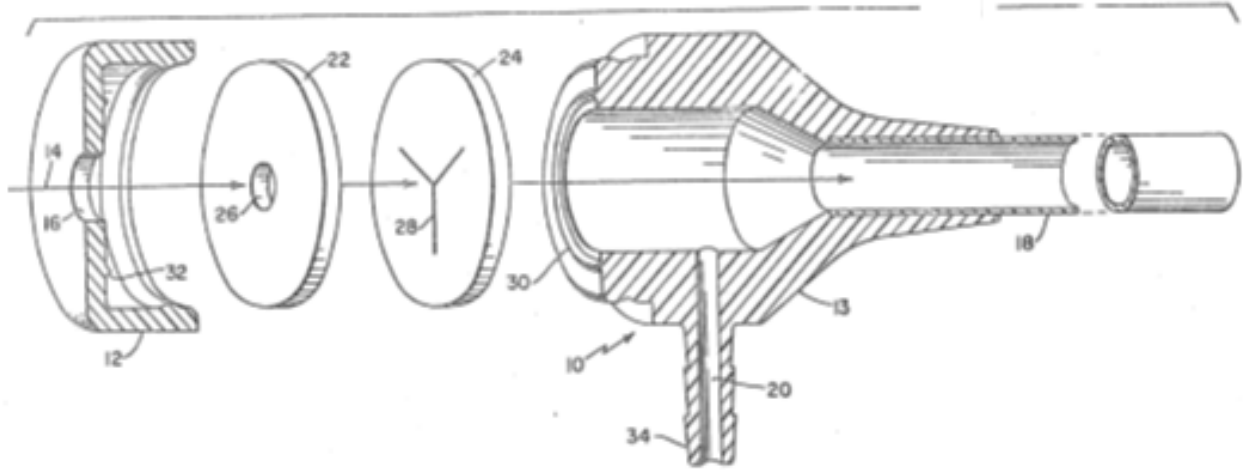

The Figure illustrates a disc (22), which provides a valve function, in conjunction with a slitted flap element (24).

A61M 2039/066

Definition statement

This place covers:

A pierceable element (such as a disc or plug shaped septum, either with or without perforations) provides the valve function when being pierced by a cannula.

Illustrative examples of subject matter classified in this place:

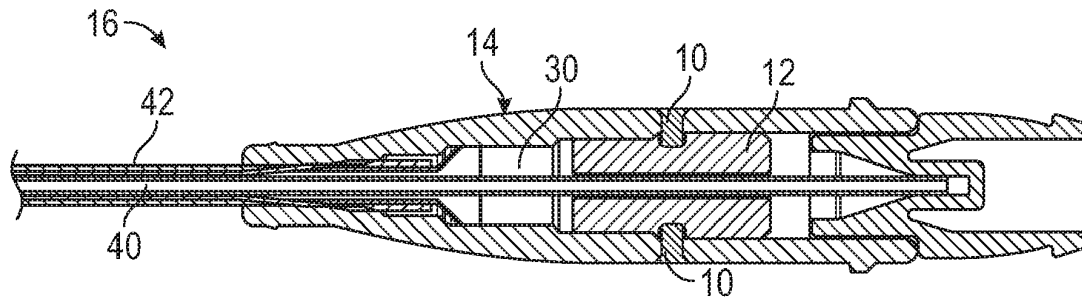

The Figure illustrates a plug (12) that provides a sealing function prior to penetration by catheter (40).

A61M 2039/0666

Definition statement

This place covers:

A valve function is provided by a movable flap element.

Illustrative example of subject matter classified in this place:

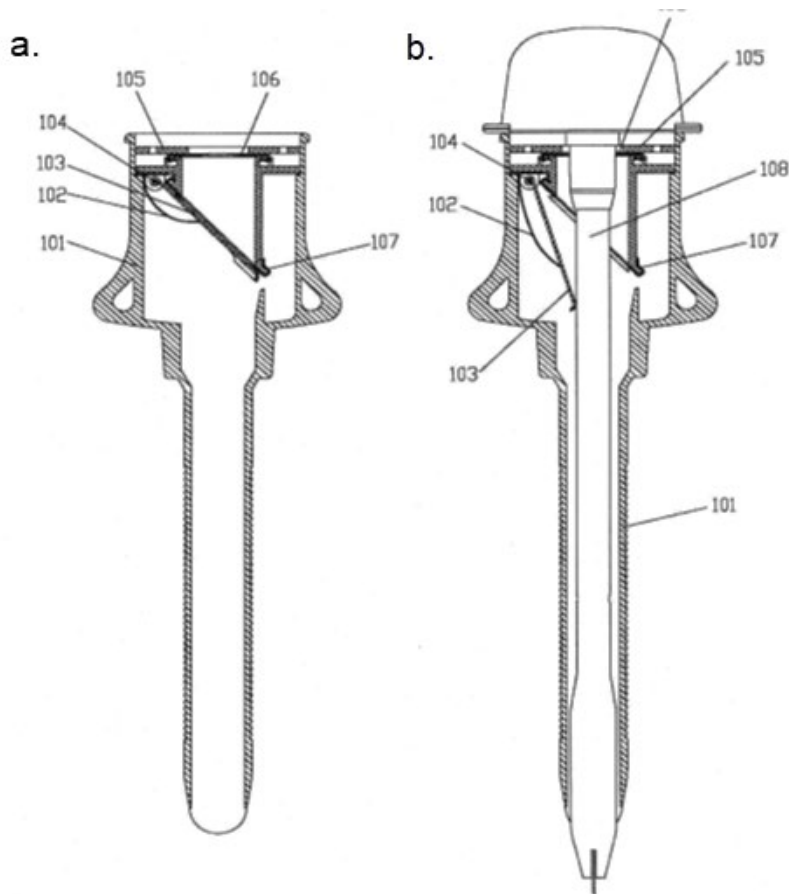

The Figure illustrates a flap valve (103) that opens when pushed by the trocar (108).

A61M 2039/0673

Definition statement

This place covers:

Haemostasis valves with means to radially bias the valve element to provide an increased pressing force that will improve sealing (with or without a catheter or the like being inserted in the valve).

Illustrative example of subject matter classified in this place:

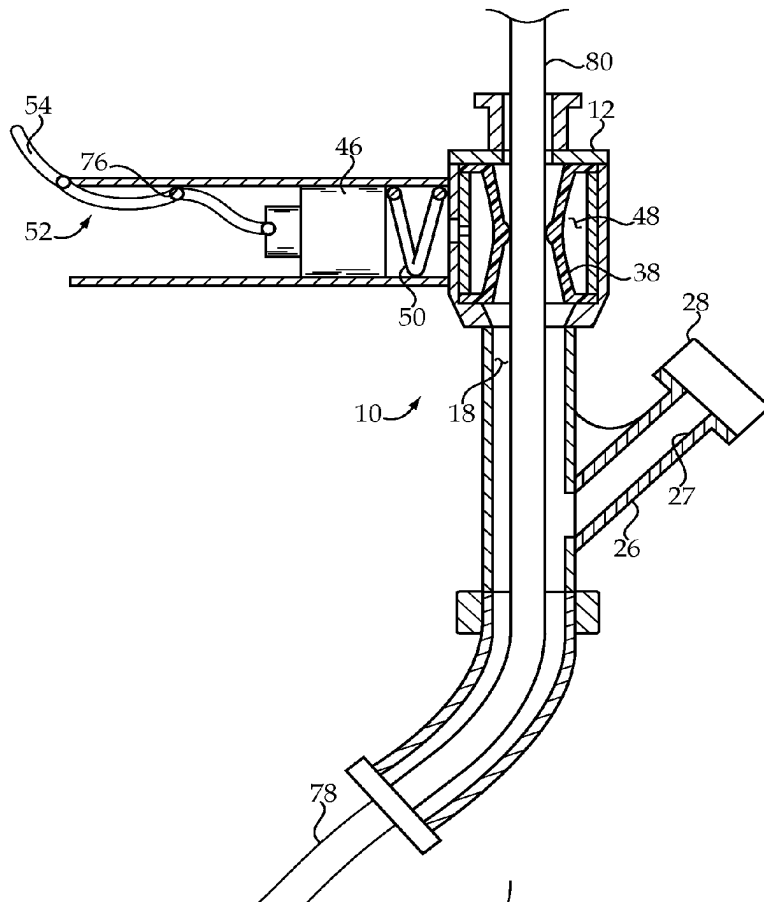

The Figure illustrates a piston (46) that acts upon compressed air in chamber (48), which acts on the valve element (38), thereby increasing the sealing force against the medical device (80).

DATE: AUGUST 1, 2026

PROJECT RP11946

A61M 39/0693**Definition statement***This place covers:*

The haemostasis valve includes means that will aid a catheter or the like to open and pass through the valve element.

Illustrative example of subject matter classified in this place:

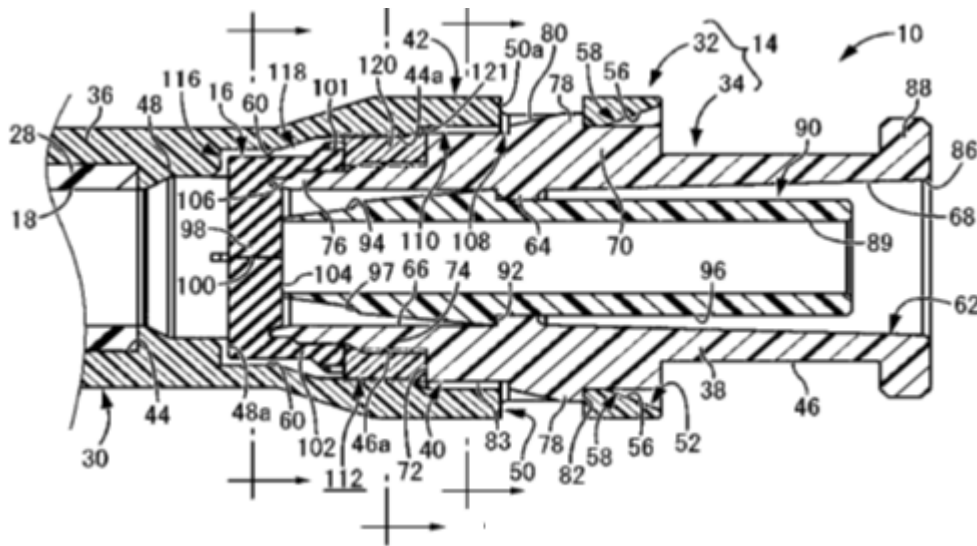

The Figure illustrates a tubular pusher (89) that will guide an inserted catheter towards the slit (100) of valve element (98). A frictional engagement causes the pusher to move together with the catheter, thereby aiding in opening the valve element.

A61M 39/08**Definition statement***This place covers:*

Tubes used to convey fluids in a medical environment, as well as handling equipment for tubes, such as storage means or special tools.

A61M 2039/087

Definition statement

This place covers:

Tools for specific use with a tube (or with tube accessories).

Illustrative example of subject matter classified in this place:

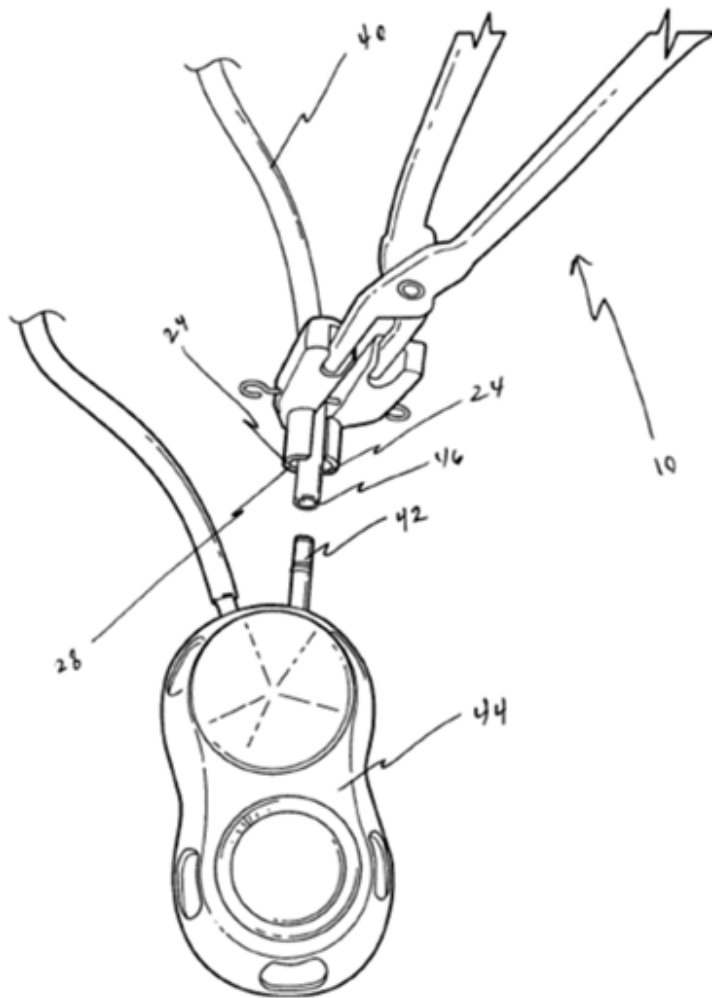

The Figure illustrates a connector removal tool (10) that is used to securely grip the tube with one hand (while pulling a connector away from the tube with the other hand).

DATE: AUGUST 1, 2026

PROJECT RP11946

References

Informative references

Attention is drawn to the following places, which may be of interest for search:

Clips, separators or the like for supporting leads	A61M 5/1418
Clamping means for squeezing flexible tubes	A61M 39/28
Lever clamps	A61M 39/284

A61M 39/10

Definition statement

This place covers:

Tube connectors or couplings used in the medical field.

Relationships with other classification places

Connectors or couplings provided on an access site device are classified in group [A61M 39/02](#).

Connections of needle (hubs) to syringes, or needles to needle hubs, are classified in group [A61M 5/34](#).

Connection of catheter tubes to hubs or similar is classified in group [A61M 25/0014](#).

Special rules of classification

Connectors with valves closing automatically on disconnection also require classification in group [A61M39/26](#).

A61M 39/1011

Definition statement

This place covers:

DATE: AUGUST 1, 2026

PROJECT RP11946

A61M 2039/1027

Definition statement

This place covers:

Connector parts that are connected mainly by axial movement, i.e. by no or only little rotation. Typical quick-acting type connectors are snap-fit and bayonet connectors.

Illustrative examples of subject matter classified in this place:

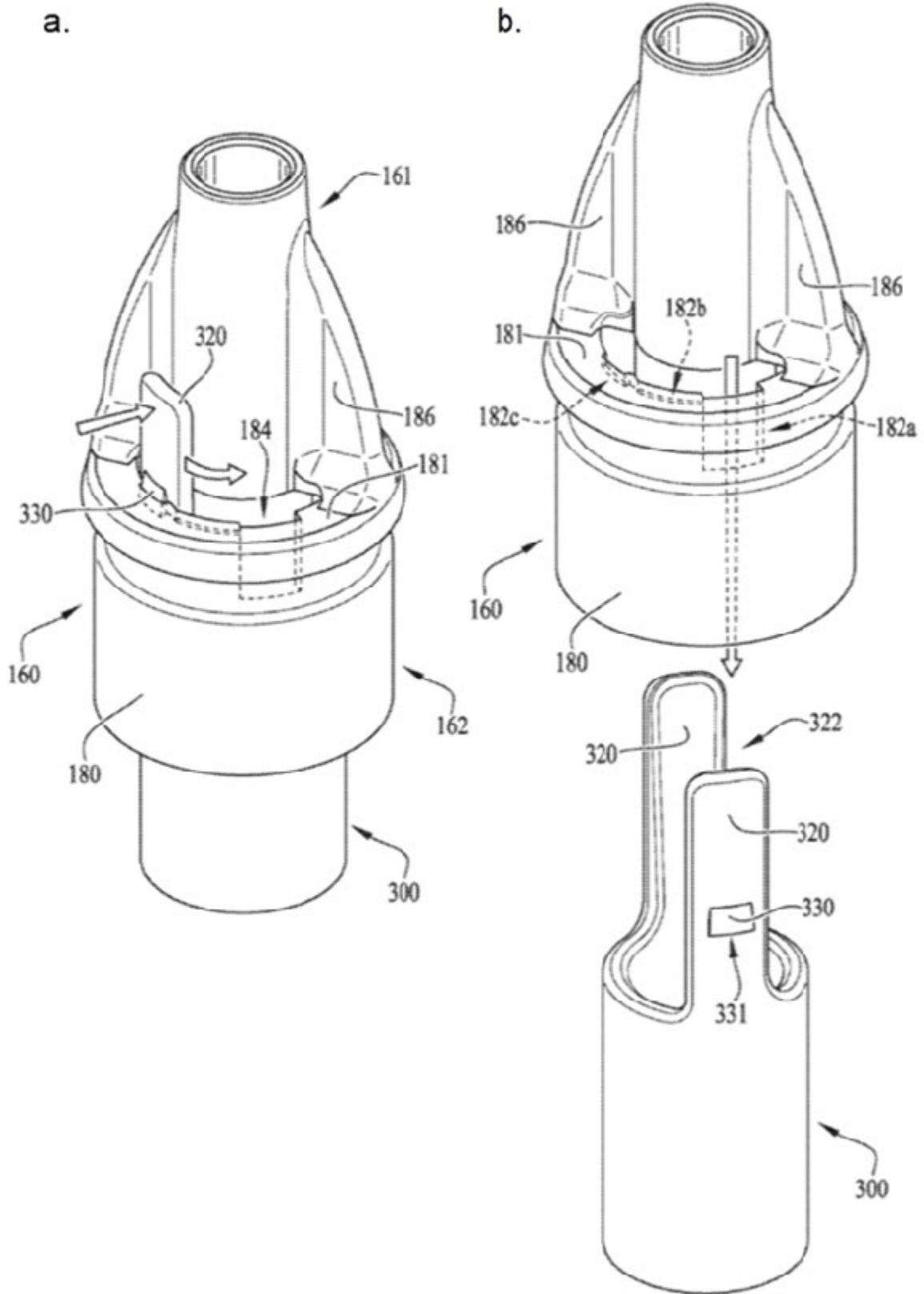

The Figure illustrates a snap fit connector comprising parts (160) and (300).

A61M 39/1033

Definition statement

This place covers:

Connector comprising a rotatable outer sleeve with inner thread to fasten the connection.

Illustrative example of subject matter classified in this place:

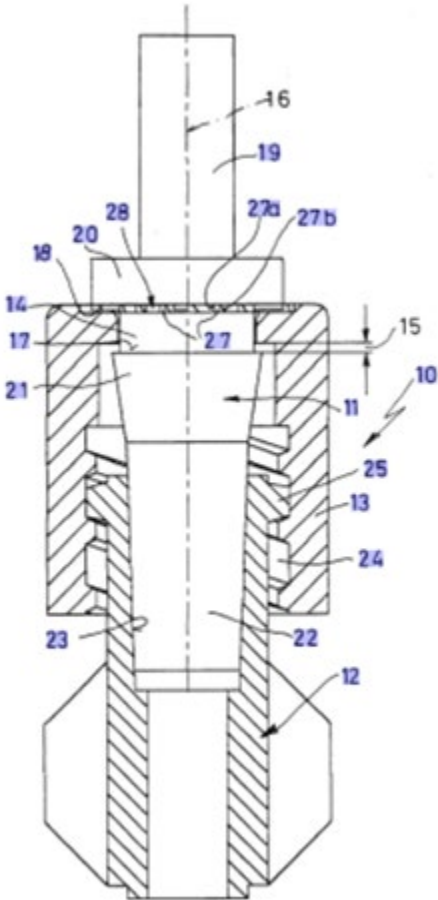

The Figure illustrates a connector comprising a sleeve (13) which is rotatable on surface (27) and can establish the connection by pulling the connector parts (11, 12) onto each other due to the threaded engagement of connector part (12) and sleeve (13).

A61M 2039/1038

Definition statement

This place covers:

Illustrative example of subject matter classified in this place:

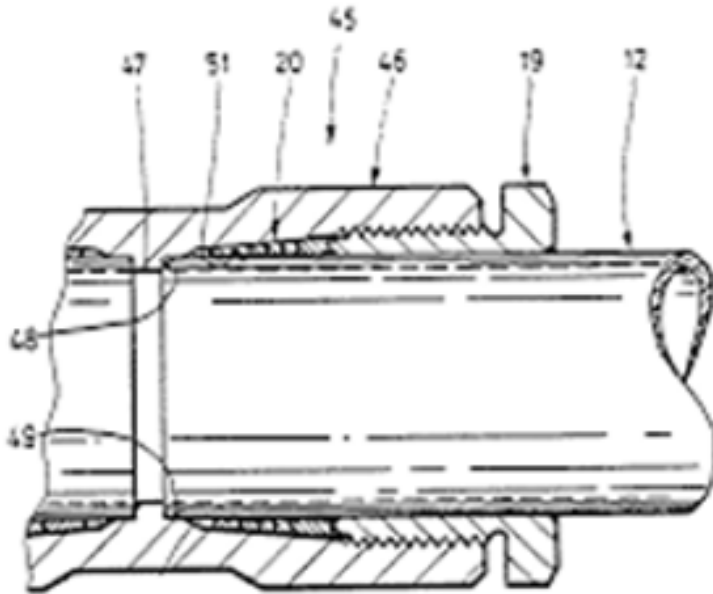

The Figure illustrates a connector comprising a sleeve like member (19) with external threads to establish or fasten the connection.

A61M 39/1055

Definition statement

This place covers:

Connector parts that are rotatable in respect to each other when connected, with one or more degrees of freedom (for a rotating joint, or swivel or ball joint, respectively).

Illustrative example of subject matter classified in this place:

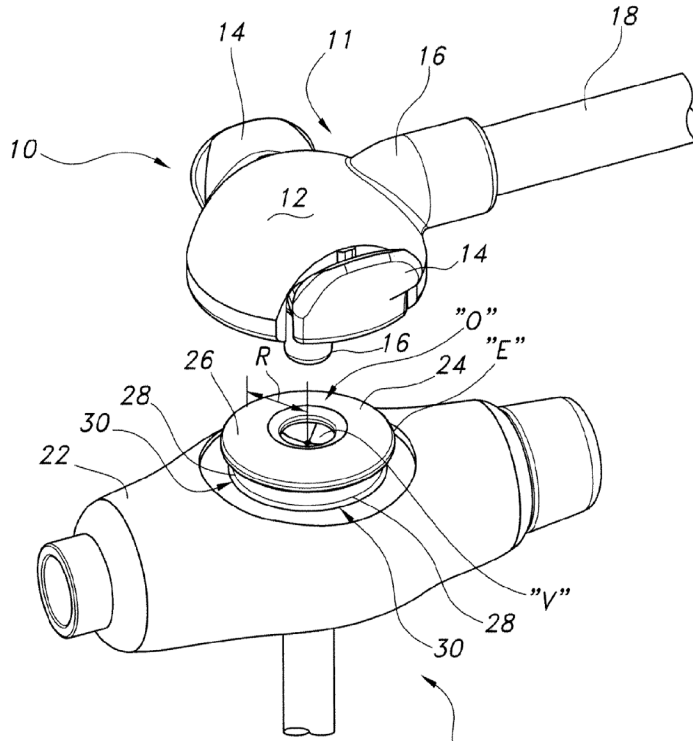

The Figure illustrates connector parts (12) and (22) which are connected to each other. In the connected state, part (12) can rotate freely with respect to the other part (22).

References

Informative references

Attention is drawn to the following places, which may be of interest for search:

Adjustable joints in general	F16L 27/00
------------------------------	----------------------------

A61M 2039/1061

Definition statement

This place covers:

Break-away or break-apart connectors are connectors that are engineered to remain connected up to a predetermined separation force at which the connector parts will decouple. They are sometimes termed quick-release or quick-disconnect connectors and are often used to prevent damage upon excessive pull force on the tubing.

DATE: AUGUST 1, 2026

PROJECT RP11946

A61M 2039/1077

Definition statement:

This place covers:

Devices providing connecting means that allow a connection of different connectors.

Connectors or connector arrangements specifically provided for allowing a connection of incompatible connectors. These connectors may be incompatible because they are different, or actually the same (i.e. male to male).

Illustrative examples of subject matter classified in this place:

- 1.

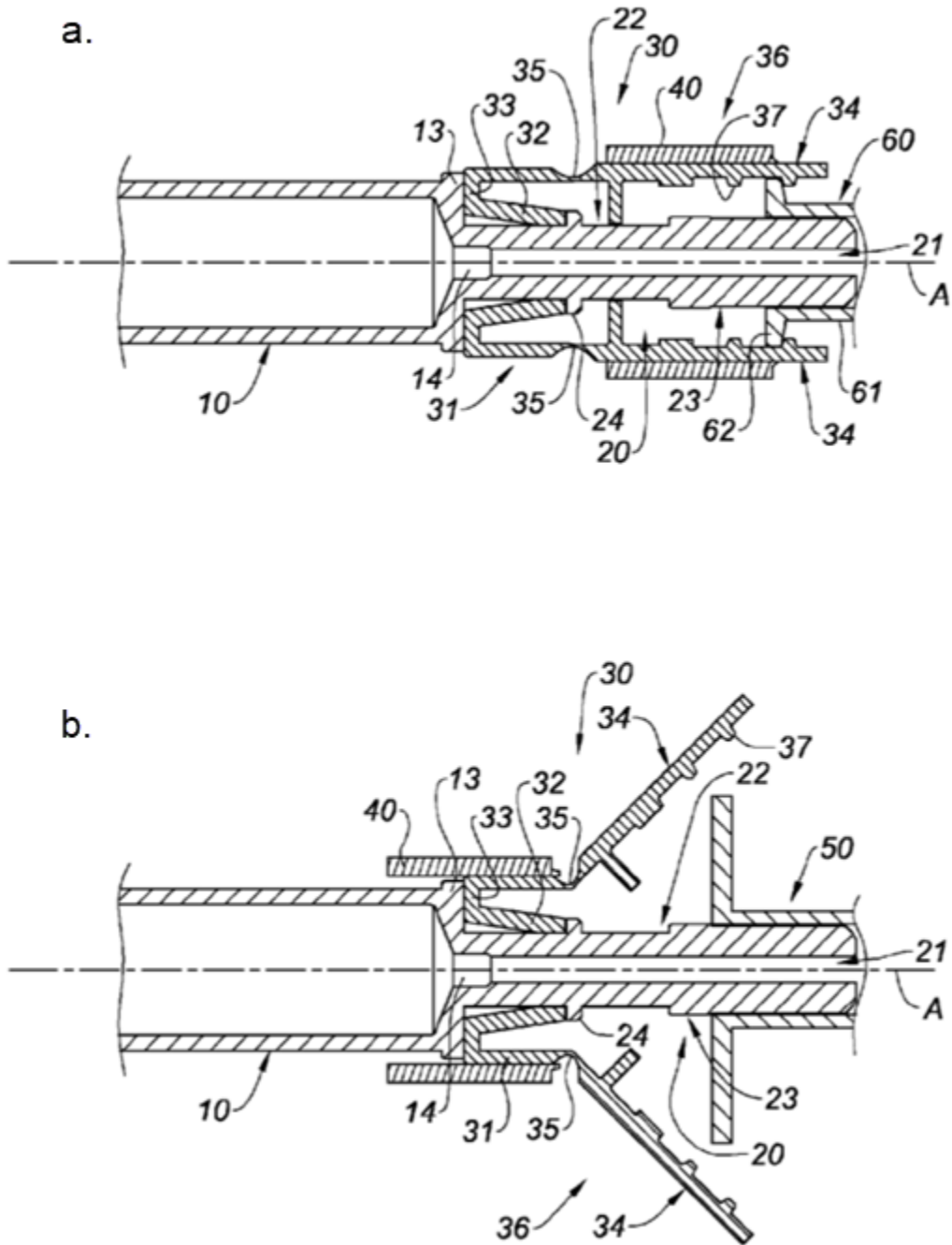

Figure 1 illustrates foldable elements (34) which provide a selectively applicable thread (for certain types of connectors).

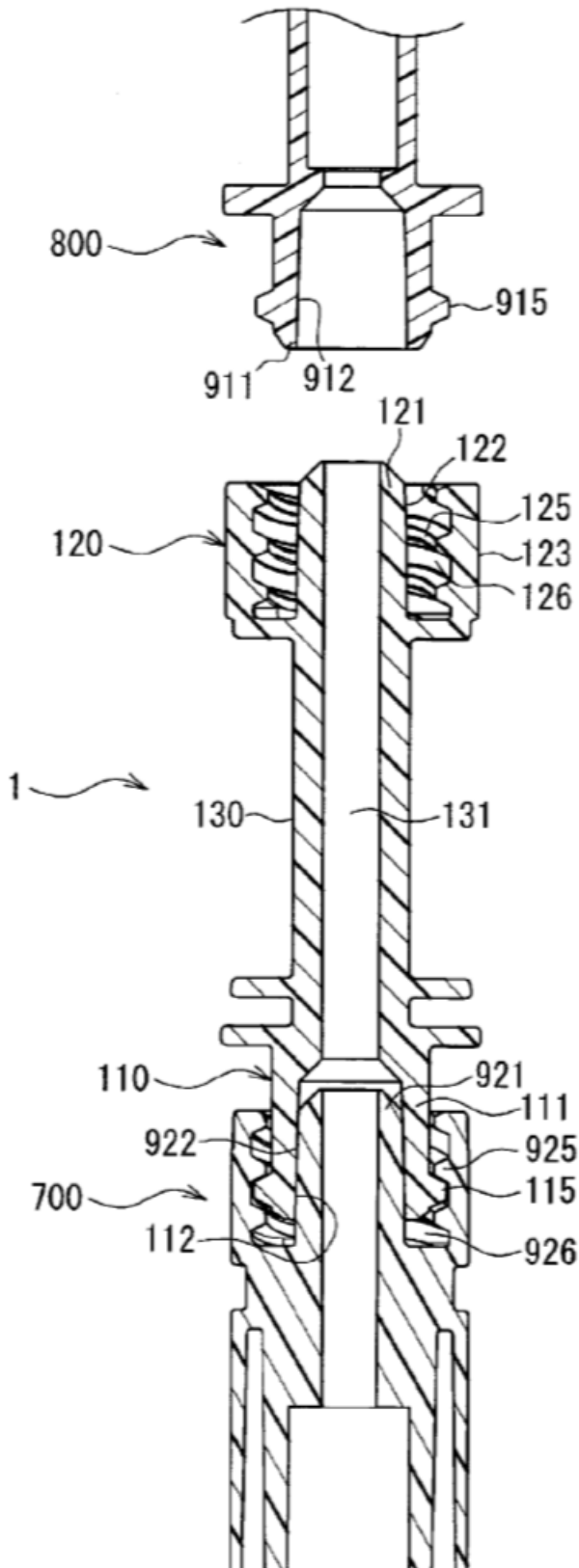

Figure 2 illustrates an adapter (1) for connecting two male components.

References

Informative references

Attention is drawn to the following places, which may be of interest for search:

Adaptors positioned between the needle hub and the syringe nozzle

A61M 5/345

A61M 2039/1094

Definition statement

This place covers:

Connectors or couplings with special connection pattern (such as respective keyed connection surfaces) or the like to make them incompatible to standard connectors.

Illustrative example of subject matter classified in this place:

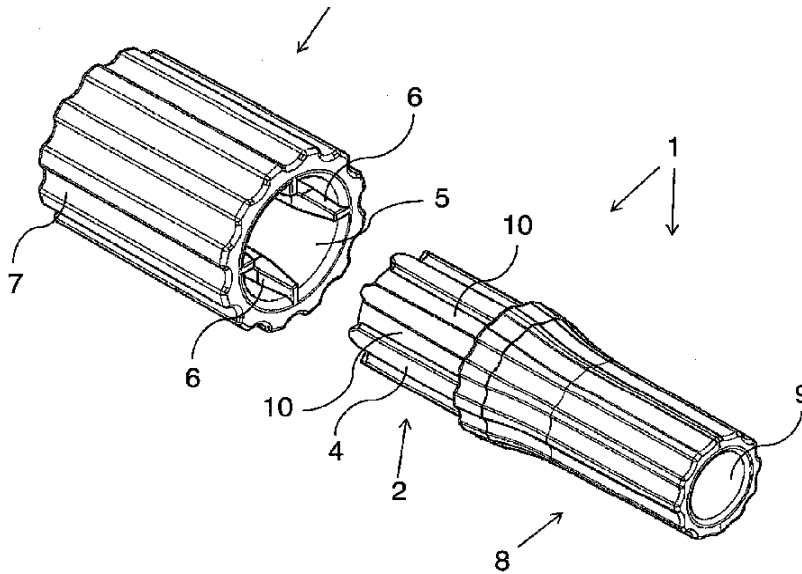

A61M 39/12

Definition statement

Connectors that enable attachment of a (flexible) tube to a rigid device (such as a pump housing). Connectors with dedicated aspects relating to the attachment of the (flexible) tube to the rigid connector should also be classified here.

Illustrative example of subject matter classified in this place:

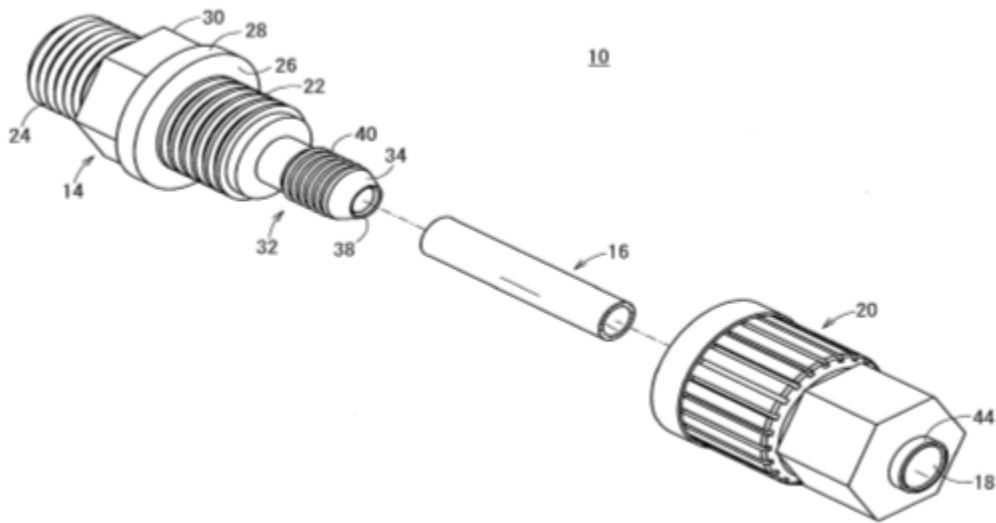

The Figure illustrates a tube (16) that is attached to tube fitting (14) by means of the internally threaded sleeve part (20).

A61M 39/14

Definition statement

This place covers:

Connectors having rupturable seals on their fluidic outlet or inlet.

Illustrative example of subject matter classified in this place:

DATE: AUGUST 1, 2026

PROJECT RP11946

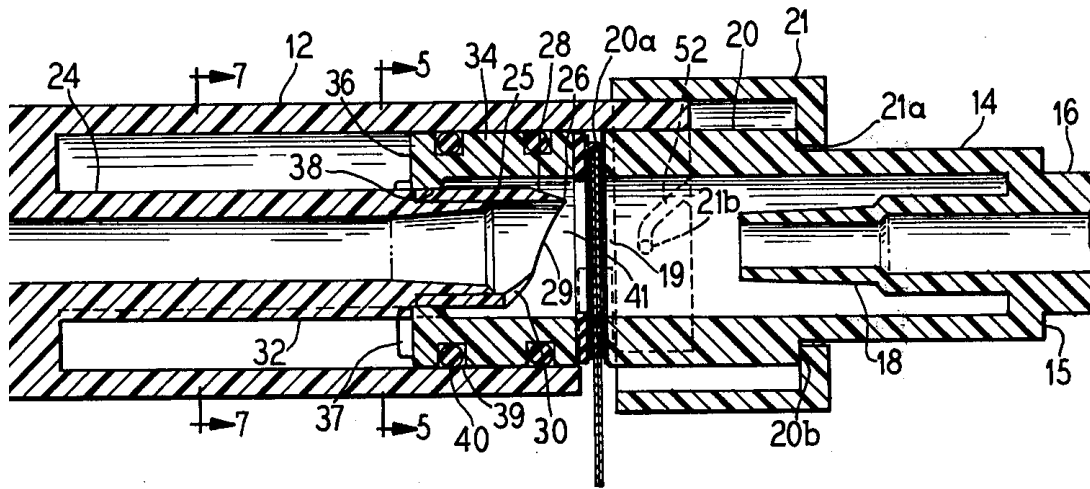

The Figure illustrates element (29) which moves forward to rupture the seals between the two fluid lines during connection.

Special rules of classification

Connectors with (reversible) valves providing a sealing function are classified in subgroup [A61M 39/22](#).

A61M 39/221

Definition statement

This place covers:

The valve comprises a seal element that is selectively openable (such as by breaking or piercing).

Relationship with other classification places

If the seal element is provided within a connector, group [A61M 39/14](#) applies. If the seal element is provided in a closure element for a container, group [A61J 1/14](#) applies.

Limiting references

This place does not cover:

Tube connectors or tube couplings for connecting tubes having sealed ends	A61M 39/14
Containers specially adapted for medical or pharmaceutical purposes; Frangible closures for containers	A61J 1/14

A61M 2039/222

Definition statement

This place covers:

The seal is located in the tubing or an (infusion) bag.

Illustrative example of subject matter classified in this place:

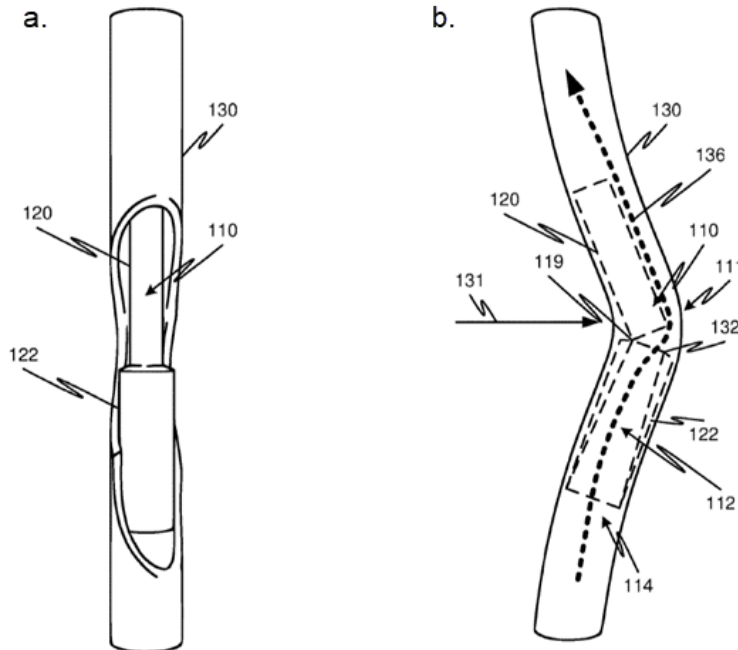

The Figure illustrates a frangible element inside a tube that breaks apart upon external force and allows a flow through the tube.

A61M 39/223

Definition statement

This place covers:

Valves with multiple inlets or multiple outlets, providing different flow paths.

Active or passive control means provide a flow path selection.

Illustrative example of subject matter classified in this place:

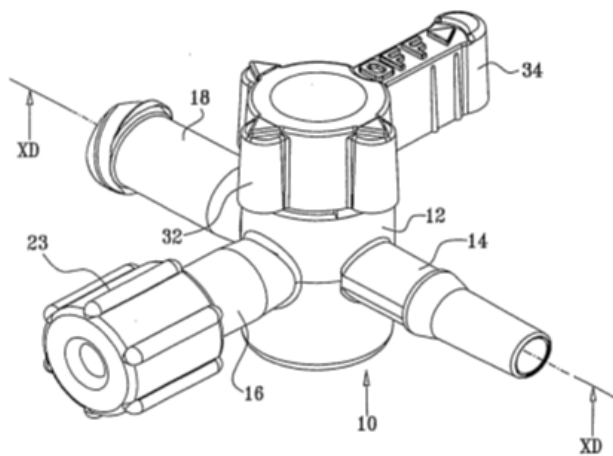

Relationship with other classification places

Passive multiway check valves are classified in group [A61M 2039/2493](#).

A61M 2039/224

Definition statement

This place covers:

Valves with a slidable element (usually laterally movable in respect to a flow direction) to selectively close or open flow lines.

Illustrative example of subject matter classified in this place:

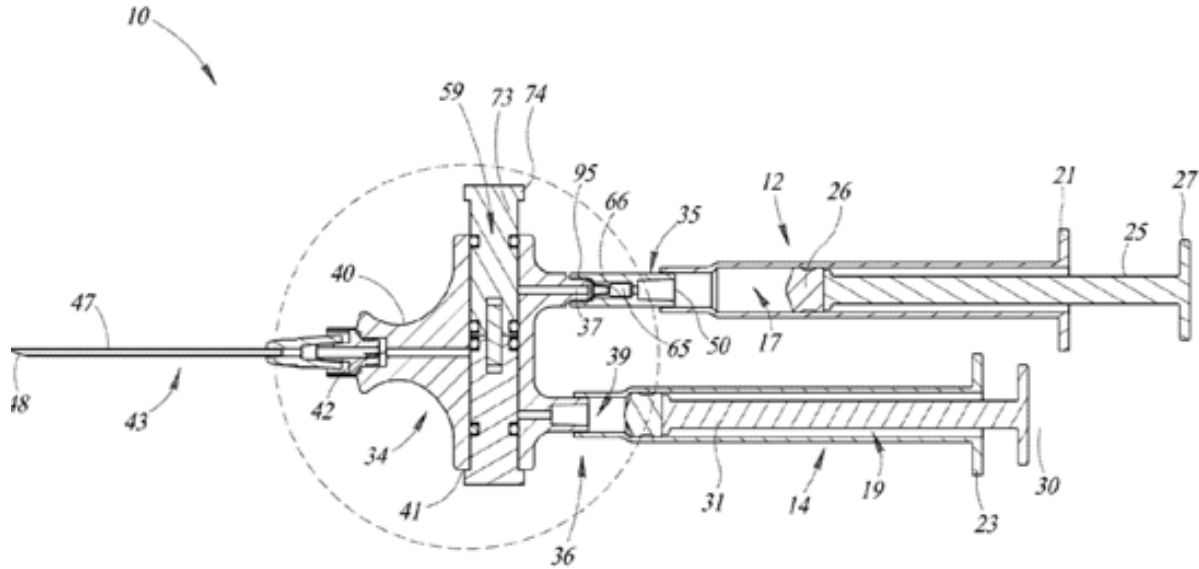

The Figure illustrates a valve assembly for selectively opening a flow line from either syringe by manipulation of piston (59).

A61M 39/225

Definition statement

This place covers:

Valves providing a dedicated flush function, such as by allowing a flow to bypass a fluidic device.

Illustrative example of subject matter classified in this place:

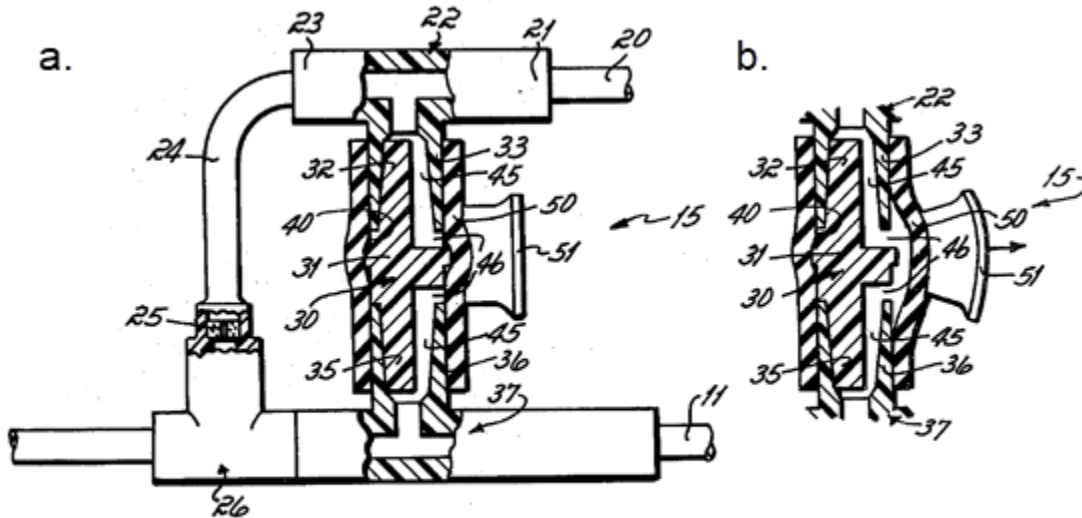

The Figure illustrates a valve that provides a dedicated flush to main tube (11) when tab (51) is pulled.

A61M 2039/226

Definition statement

This place covers:

The valve having a spindle or other actuating means for selecting or manipulating a flow path.

Illustrative examples of subject matter classified in this place:

- 1.

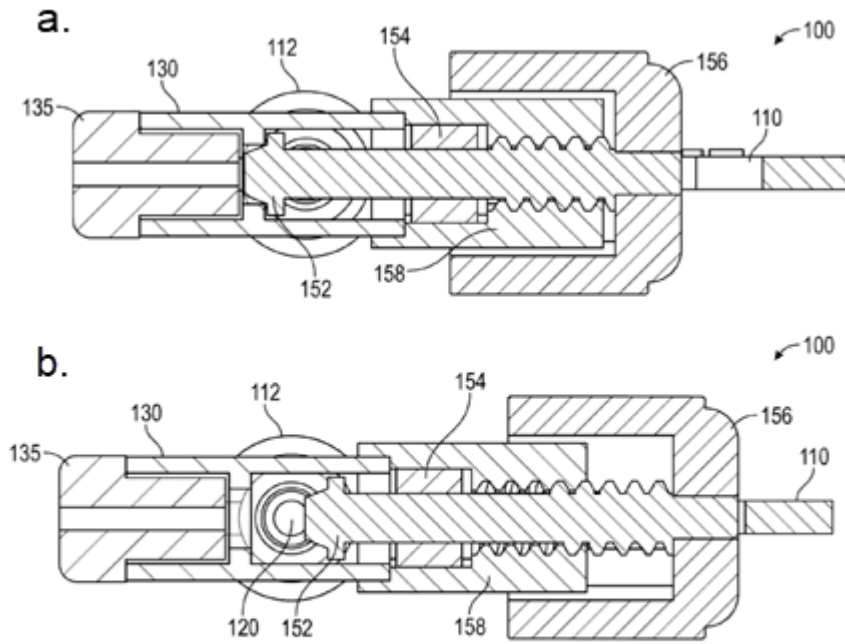

Figure 1 illustrates a spindle-head (152) which selectively opens and closes port (135).

2.

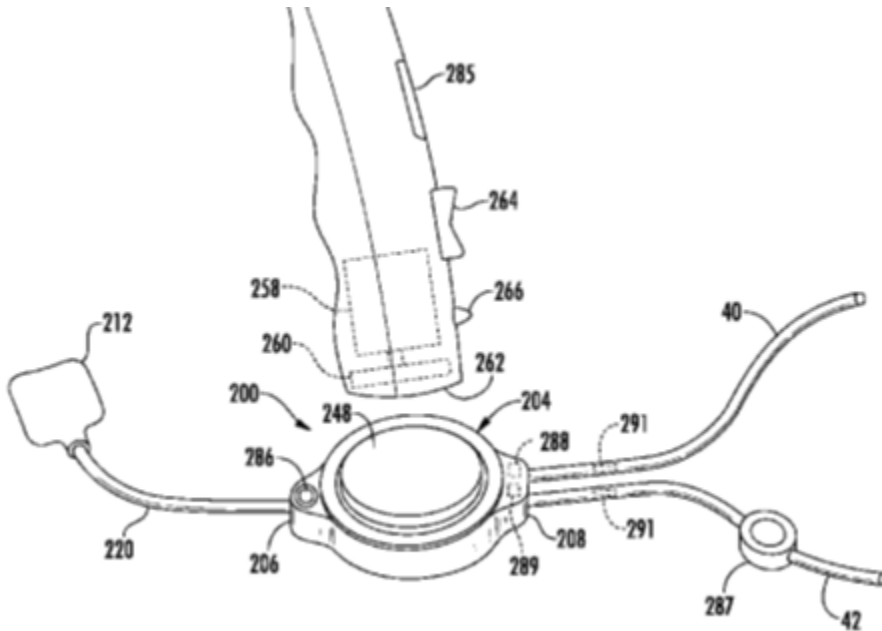

Figure 2 illustrates a valve inside the housing (204) that is activated by magnet a (260).

A61M 39/229

Definition statement

This place covers:

Valves with a single flow path and usually with a rotatable (i.e. stopcock) or a slidable valve member which is actively manipulated by a user.

Illustrative example of subject matter classified in this place:

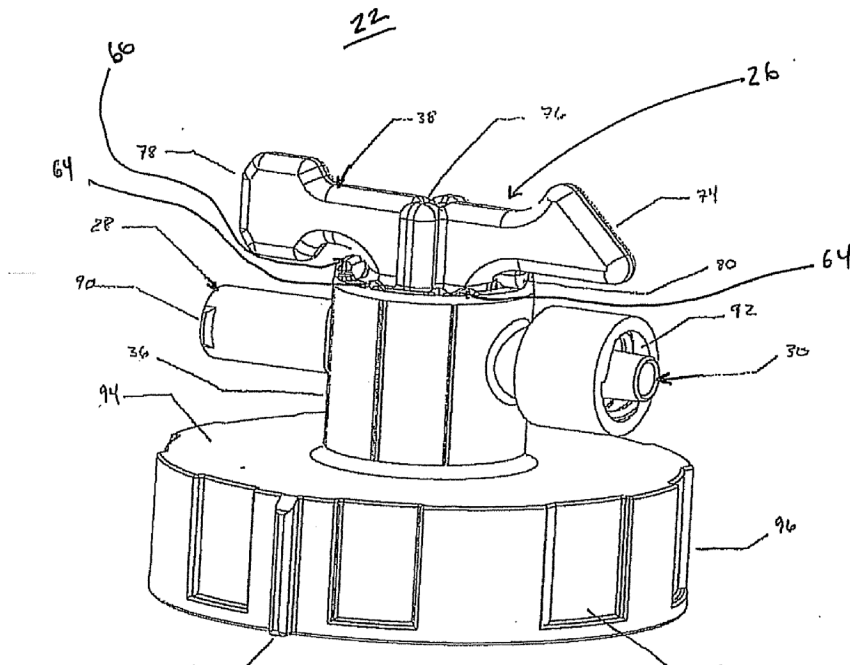

The Figure illustrates a rotatable lever (36) that enables the cut-off of a flow between inlet (30) and outlet (90).

A61M 39/24

Definition statement

This place covers:

Passive valves that prevent backflow or only open upon a predefined pressure. Valve opening and closure is usually determined by the pressure conditions of the fluid on both sides of the valve and any pre-tension in the valve element.

Relationship with other classification places

Active valves are classified in groups [A61M 39/225](#), [A61M 2039/226](#), [A61M 39/227](#) and [A61M 39/229](#).

DATE: AUGUST 1, 2026

PROJECT RP11946

A61M 2039/2493**Definition statement***This place covers:*

Passive valves with additional functions provided, for example, by a fluidic network of one or more (passive) check valves such as multiple fluidic channels.

Illustrative example of subject matter classified in this place:

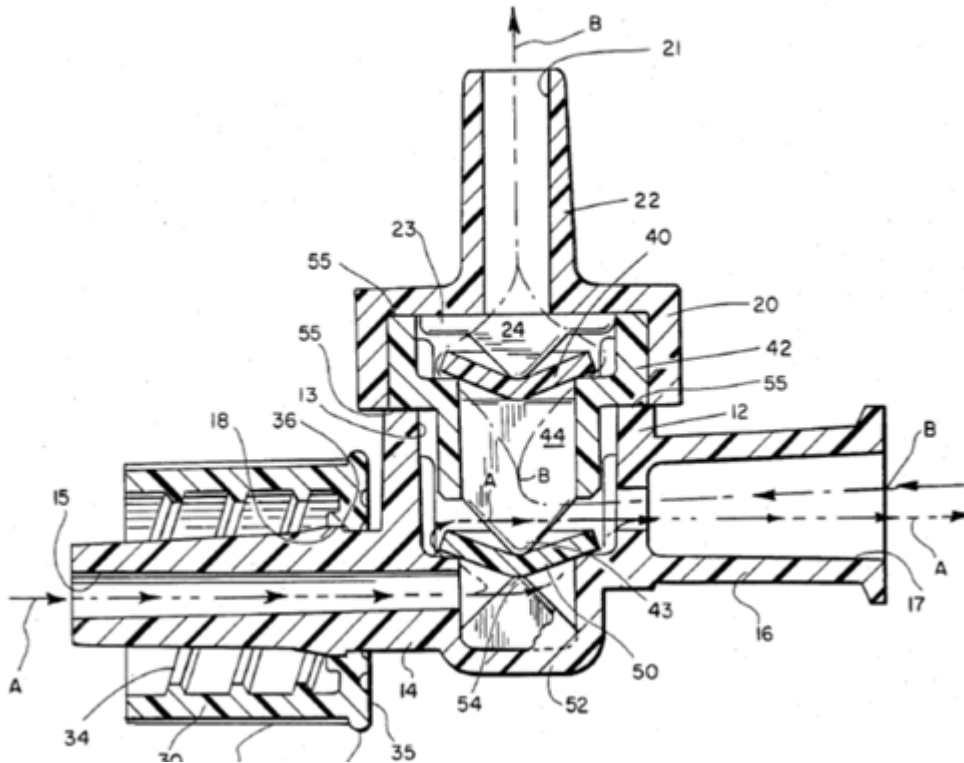

The Figure illustrates a double check valve arrangement that allows the flow entering via input (15) to be selectively directed to either output (17) or output (21).

Relationship with other classification places

For active valves with multiple channels classification is to be considered in group [A61M 39/223](#).

A61M 2039/261

Definition statement

This place covers:

During closure or disconnection of a second connector from a first connector a fluid space in the first connector part increases which leads to a fluid being sucked into this space (and usually away from the first connector opening).

Illustrative example of subject matter classified in this place:

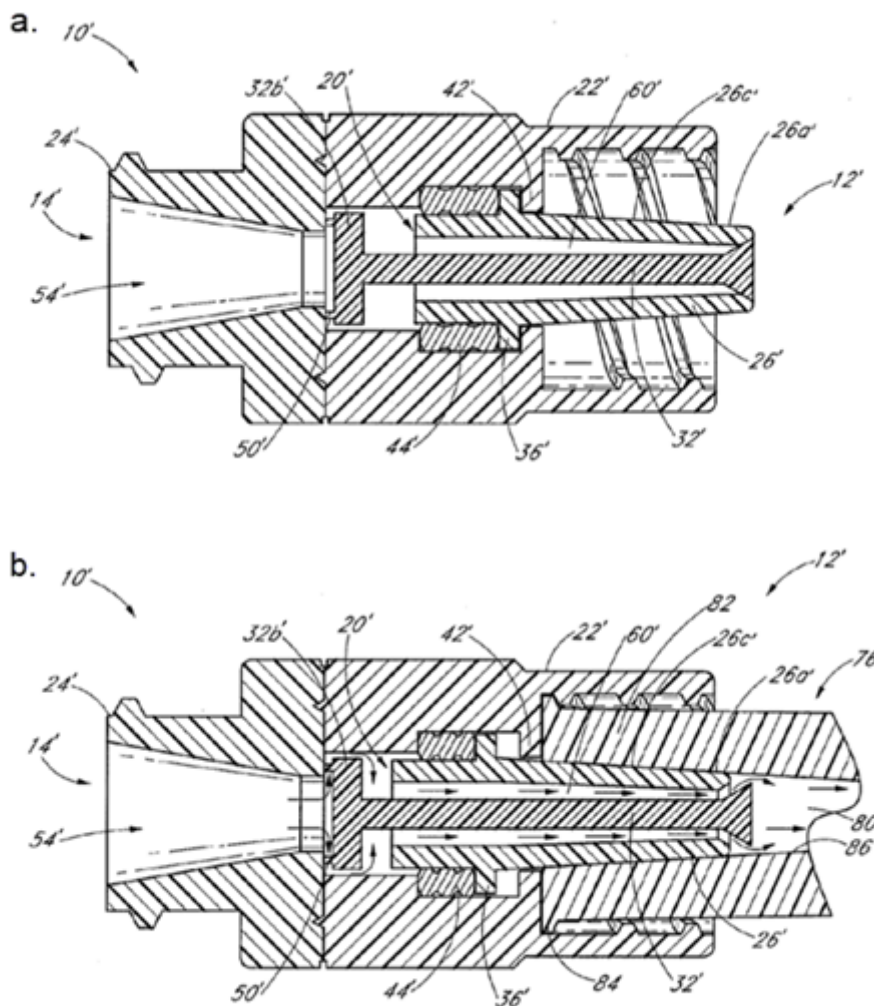

The Figure illustrates a cross-sectional view of a luer connector (10') in a first or closed position (a) and in a second or open position (b) due to engagement of a female

DATE: AUGUST 1, 2026

PROJECT RP11946

connector (76) with the luer connector (10'). When the female connector (76) is disengaged from the luer connector (10'), the luer tip (26') returns to the closed position relative to the valve tube 32', thereby increasing the fluid space at (20') which acts to prevent fluid escaping from the luer connector 10'.

A61M 2039/263

Definition statement

This place covers:

During closure or disconnection of a second connector from a first connector, a fluid space in the first connector part decreases, thus resulting in a pressure increase that expels fluid from the fluid space (usually towards the opening of the first connector).

Illustrative example of subject matter classified in this place:

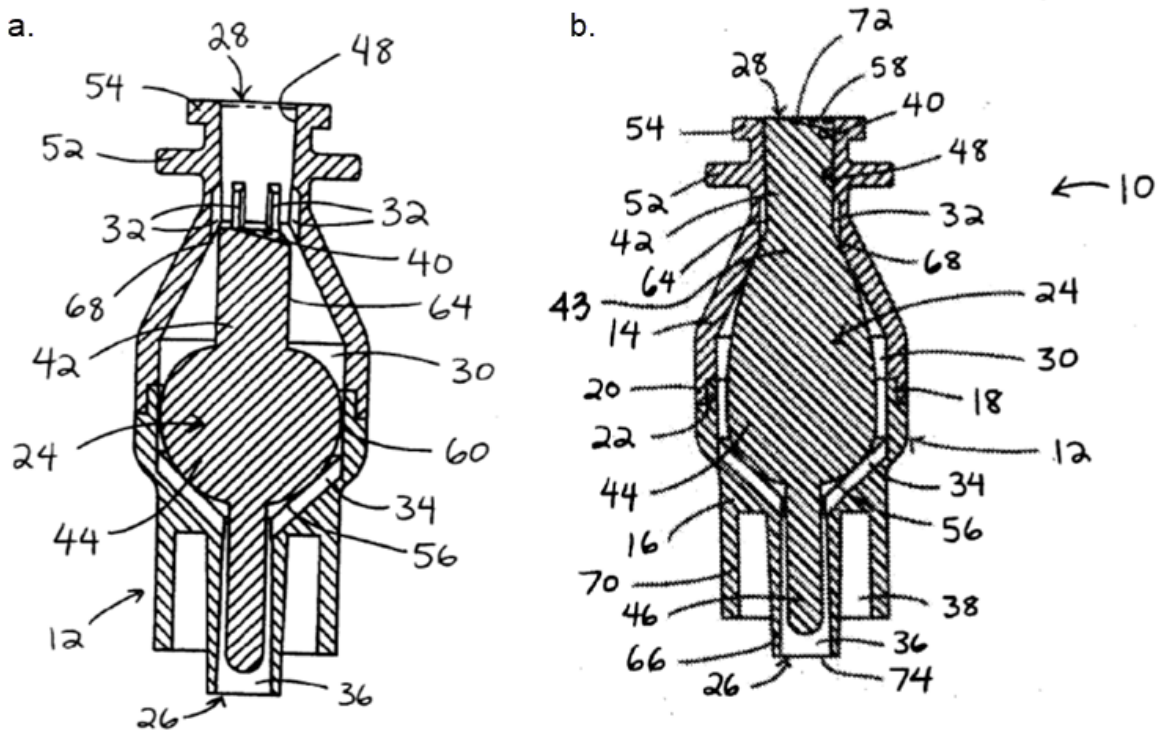

The Figure illustrates a compressible plug (24) that expands during disconnection of a second connector from port (28), thus reducing the fluid space (30). Flow channels (34) guide the fluid flow away from port (28), i.e. towards port (26).

A61M 39/284

Definition statement

This place covers:

Clamps comprising a rotatable lever or arm-like element which acts on the tubing.

Illustrative example of subject matter classified in this place:

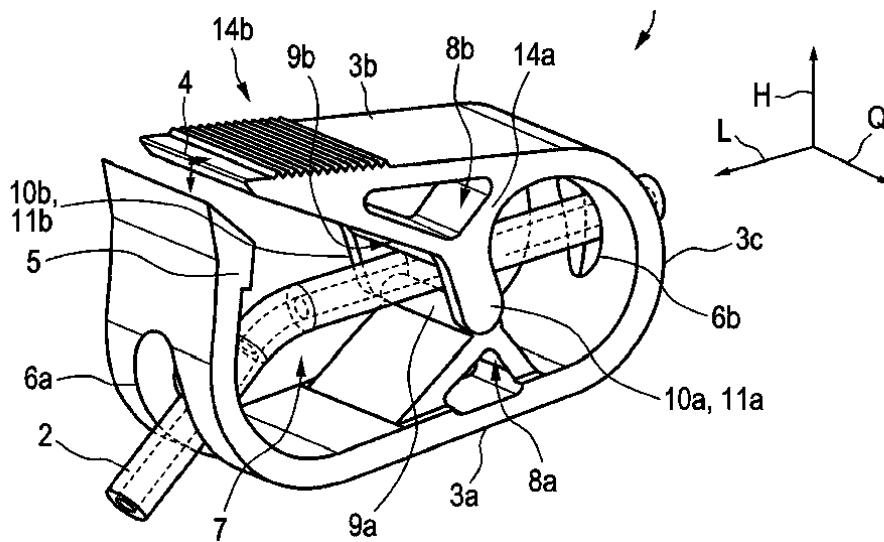

DATE: AUGUST 1, 2026

PROJECT RP11946

2. A. DEFINITIONS (modified)

A61M 5/00

Definition statement

Replace: The Definition statement text with the revised text below.

Infusion devices (e.g. infusion by gravity, infusion pumps, infusion needles or flow control), syringes and details therefrom (e.g. automatic syringes, ampoules syringes, syringe cartridges, pistons or needles), means for preventing injection of air in body, means for desensitising skin, means for cooling or heating media to be infused, means for controlling depth of insertion.

Insert: The following new Relationships section.

Relationships with other classification places

Syringes can also be classified in other fields ([A61J 1/00](#) - [A61J 1/22](#), [A61B 5/14](#), [A61B 17/00](#) - [A61B 17/921](#)). General details of syringes (e.g. caps, constructional features, priming, valves, plugs, filling) can be classified in the subgroup [A61M 5/31](#).

In group [A61B 8/0891](#), the blood vessel is analysed for diagnosis purpose using ultrasonic, sonic or infrasonic waves. All couplings and connectors are classified in group [A61M 39/00](#).

References

Limiting references

Replace: The Limiting references table with the revised table below.

Suction or pumping devices for medical purposes; Devices for carrying-off, for treatment of, or for carrying-over, body-liquids; Drainage systems	A61M 1/00
Catheters; Hollow probes	A61M 25/00
Measuring for diagnostic purposes; Identification of persons	A61B 5/00
Devices for taking samples of blood	A61B 5/15

CPC NOTICE OF CHANGES 1933

DATE: AUGUST 1, 2026

PROJECT RP11946

Devices or methods for introducing solid, liquid or gaseous remedies or other materials into or onto the bodies of animals	A61D 7/00
Implantable gland structures or devices, e.g. implantable artificial pancreas	A61F 2/022
Containers for medicinal or pharmaceutical purposes	A61J 1/00
Medicinal preparations	A61K 35/00
In vitro human cell grow apparatus	C12M 3/00

Informative references

Replace: The Informative references table with the revised table below.

Blood transfusion	A61M 1/02
Means for agitating	A61M 1/025
Blood oxygenators	A61M 1/14
Filtering material out of the blood by passing it through a membrane, i.e. hemofiltration or diafiltration	A61M 1/34
Other treatment of blood in a by-pass of the natural circulatory system, e.g. temperature adaptation, irradiation; Extra-corporeal blood circuits	A61M 1/36
Temperature treatment for blood	A61M 1/369
Pressure measurement lumen	A61M 2025/0003
Connecting catheter tubes to hubs	A61M 25/0014
Guide needles for catheters	A61M 25/065
Diffusion through the skin	A61M 35/00
Microneedles	A61M 37/00

CPC NOTICE OF CHANGES 1933

DATE: AUGUST 1, 2026

PROJECT RP11946

Measuring of body parameters	A61B 5/00
Syringes for taking blood samples	A61B 5/14
Surgical glue applicators	A61B 17/00491
Syringes for injecting impression materials	A61C 9/0026
Making filter elements	B01D 29/111
Burettes, measuring cylinders for laboratory use	B01L 3/02
Chemical or physical laboratory apparatus for heating or cooling in general	B01L 7/00
Disintegrating medical waste	B02C 19/0075
Destroying solid waste or transforming solid waste into something useful or harmless	B09B 3/00
Making of hollow needles	B21G 1/08
Grinding sharp-pointed work pieces	B24B 19/16
Filling medical containers such as ampoules, vials, syringes or the like	B65B 3/003
Pressurised by contraction of elastic reservoir, in general	B65D 83/7711
Receptacles for refuse disposal in general	B65F 1/00
Cell injection devices	C12M 3/006
Linear peristaltic pumps, in general	F04B 43/12
Telescopic rods	F16B 7/10
Valves in general	F16K
Heat exchange in general	F28
Hypodermic projectiles	F42B 12/54

CPC NOTICE OF CHANGES 1933

DATE: AUGUST 1, 2026

PROJECT RP11946

Apparatus of the syringe type	G01F 11/027
Indicating or measuring liquid levels	G01F 23/292
Systems or apparatus for checking the occurrence of a condition	G07C 11/00
Holders comprising label	G09F 3/0295
ICT specially adapted for therapies or health-improving plans (e.g. for handling prescriptions, for steering therapy or for monitoring patient compliance) relating to drugs or medications (e.g. for ensuring correct administration to patients)	G16H 20/10
Holders for storage of radioactive sources	G21F 5/018
Heating by electric fields	H05B 6/80

Delete: The entire Special rules section.

A61M 5/14228

Insert: The following new Definition statement text and image.

Definition statement

This place covers:

Infusion pumps in which the infusion fluid is moved by sequential pressurisation, usually by finger-like or solenoid actuators acting perpendicular to the flow direction.

Illustrative example of subject matter classified in this place:

DATE: AUGUST 1, 2026

PROJECT RP11946

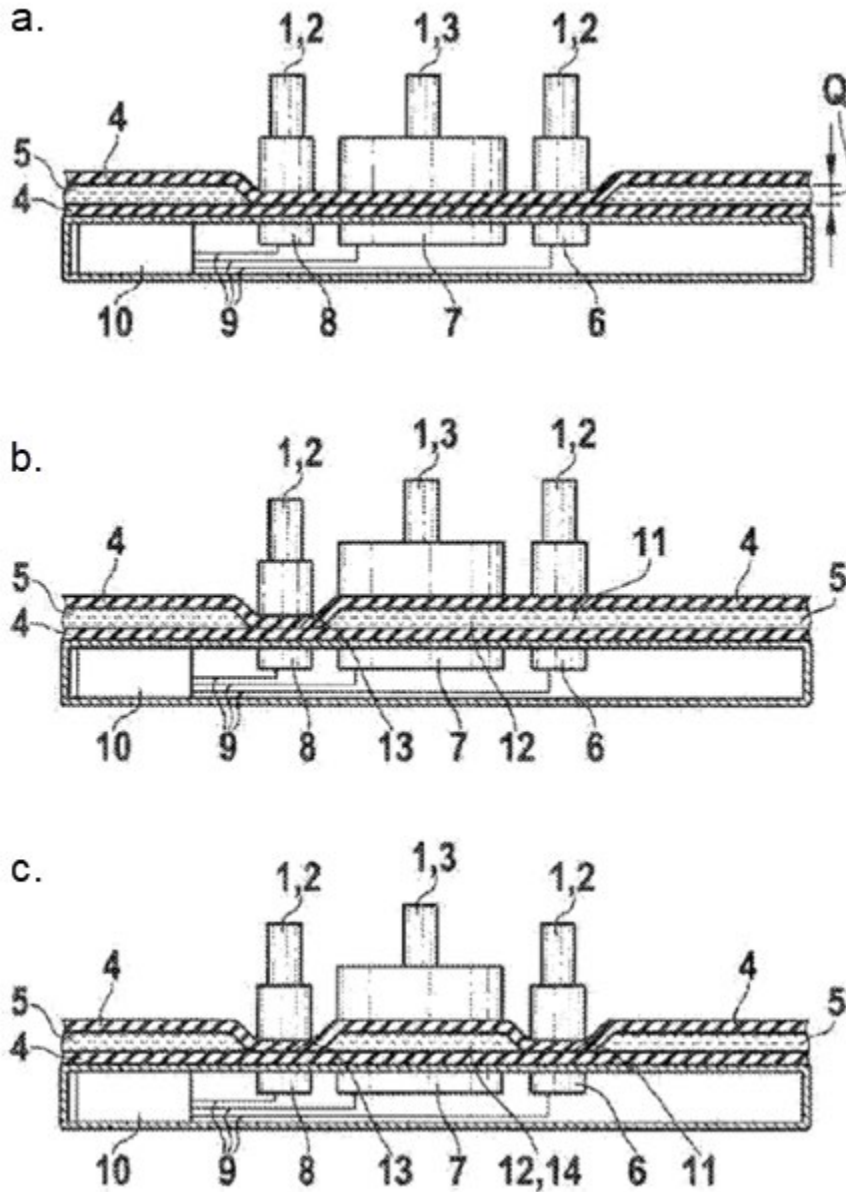

The Figure illustrates solenoids (1,2) and (1,3) which act upon fluid line (4). In this particular example, the solenoids (1,2) act more like valves than true peristaltic fingers.

Insert: The following new Relationships section.

DATE: AUGUST 1, 2026

PROJECT RP11946

Relationship with other classification places

Rotational peristaltic pumps in which roller elements move along the flow direction are classified in subgroup [A61M 5/14232](#).

A61M 5/14232

Insert: The following new Definition statement text and image.

Definition statement

This place covers:

Infusion pumps in which the infusion fluid is moved by pressurisation of the fluid line by roller elements which move along the flow direction.

Illustrative example of subject matter classified in this place:

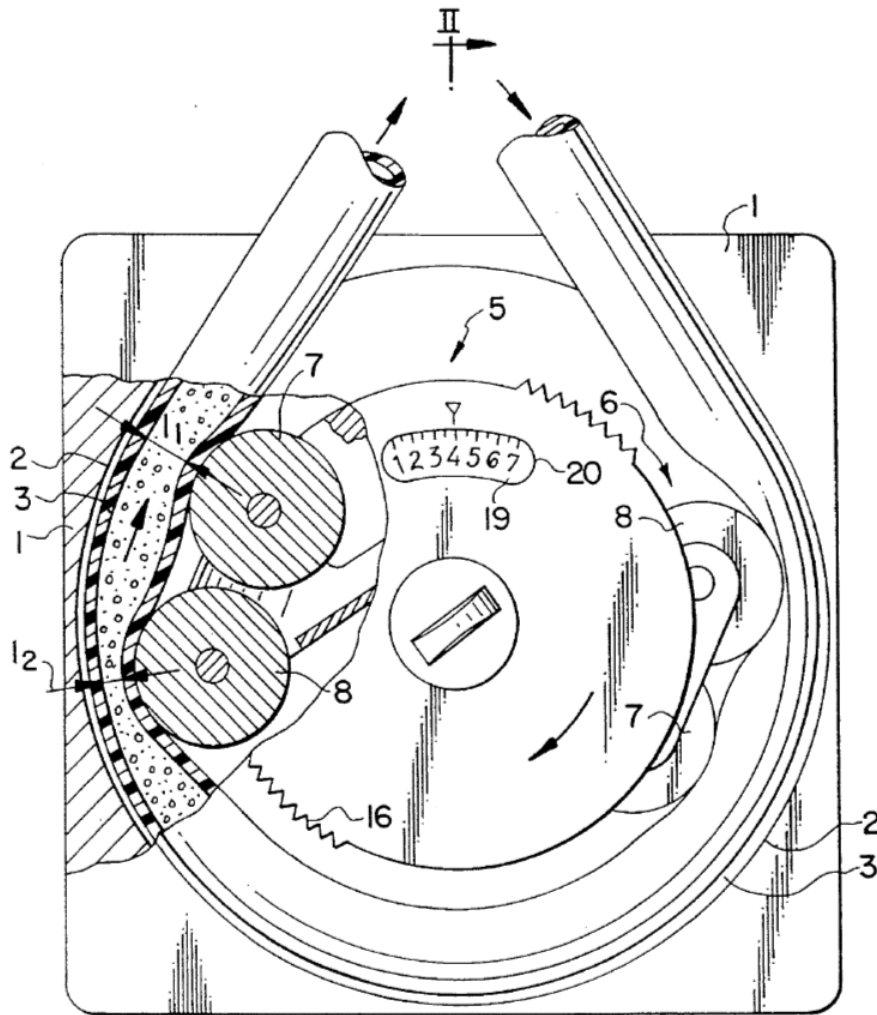

The Figure illustrates a disc (5) which rotates (as indicated by the arrow) such that the rollers (7) and (8) act upon the flow line (3) to push liquid in the indicated direction.

A61M 2005/14288

Insert: The following new Definition statement.

Definition statement

This place covers:

Infusion devices, or related assemblies and arrangements, for simulating an infusion or injection. Training devices are also classified here.

A61M 2005/1586

Insert: The following new Definition statement text and image.

Definition statement

This place covers:

Means for attaching the infusion needle to the patient's skin. The needle may include attached infusion tubing.

Illustrative example of subject matter classified in this place:

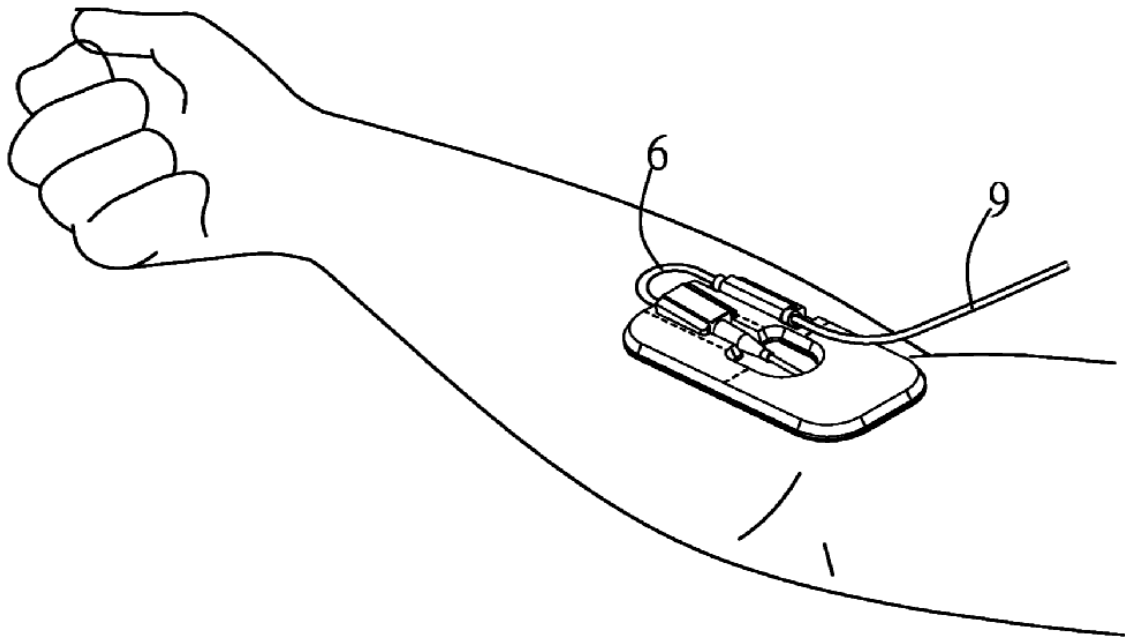

A61M 39/00

Definition statement

Replace: The Definition statement text with the revised text below.

Access sites (subcutaneous or transcutaneous), haemostasis valves, medical tubes or means for storage of said tubes, tube connectors, caps or plugs for tubes or connectors, valves or clamping means for medical tubes.

DATE: AUGUST 1, 2026

PROJECT RP11946

References***Limiting references***Replace: The Limiting references table with the revised table below.

Devices for influencing the respiratory system of patients by gas treatment, e.g. ventilators; Tracheal tubes	A61M 16/00
Implantable artificial heart or vascular valves	A61F 2/24

Informative referencesReplace: The Informative references table with the revised table below.

Catheters for peritoneal dialysis systems	A61M 1/285
Arterio-venous shunts or fistulae for extra-corporeal blood circuits	A61M 1/3655
Tube strippers for medical suction or pumping devices	A61M 1/83
Needles for infusion devices	A61M 5/158
Regulating valves in infusion systems	A61M 5/16881
Means for protection against accidental injuries by used needles	A61M 5/321
Constructions for connecting needles to syringes or needle hubs	A61M 5/34
Locating means to allow access to septum	A61M 5/427
Measuring fluid pressure within the body other than blood pressure	A61B 5/03
Cranial plugs for access to brain	A61B 2090/103
Colostomy devices	A61F 5/445

CPC NOTICE OF CHANGES 1933

DATE: AUGUST 1, 2026

PROJECT RP11946

Gastrotomy feeding tubes	A61J 15/0015
Method or apparatus for disinfecting or sterilising materials or objects other than foodstuffs or contact lenses	A61L 2/00
Diaphragm valves or cut-off apparatus constrictable by means of a screw-spindle, cam or other mechanical means	F16K 7/06
Diaphragm valves or cut-off apparatus constrictable by means of fluid pressure	F16K 7/07
Multiple-way valves, e.g. mixing valves; Pipe fittings incorporating such valves	F16K 11/00
Screw-threaded pipe joints; Forms of screw-threads for such joints	F16L 15/00
Pipe joints in which sealing surfaces are pressed together by means of a member	F16L 19/00
Adjustable pipe joints; Pipe joints allowing movement	F16L 27/00
Arrangements for connecting hoses to rigid members; Rigid hose-connectors	F16L 33/00
Couplings of the quick-acting type	F16L 37/00
Couplings of the quick-acting type for double-walled or multi-channel pipes	F16L 37/56

Special rules of classification

Replace: The Special rules text with the revised text below.

If the check valve is well described and presents some interesting features, then the document should also be classified in the field of valves (group [A61M 39/22](#)).

A61M 2039/085

Insert: The following new Definition statement.

Definition statement

This place covers:

Enteral feeding tubes usually introduced through the nose or the mouth to the gastric system of a patient.

Illustrative example of subject matter classified in this place:

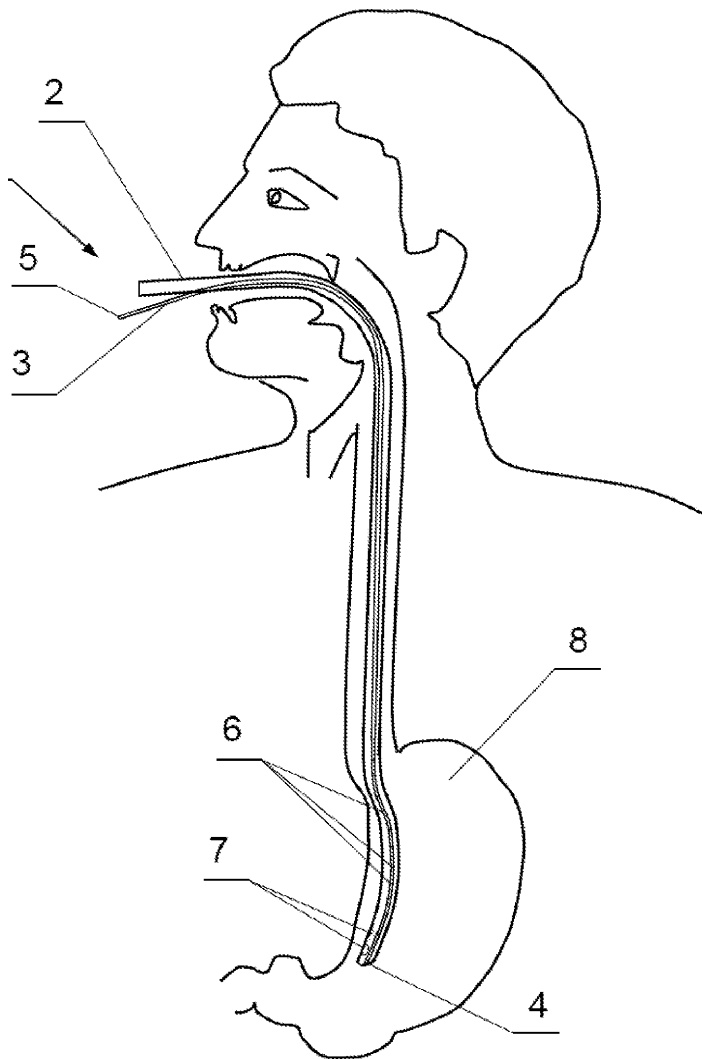

The Figure illustrates an enteral feeding tube (2).

CPC NOTICE OF CHANGES 1933

DATE: AUGUST 1, 2026

PROJECT RP11946

3. REVISION CONCORDANCE LIST (RCL)

Type*	From CPC Symbol (existing)	To CPC Symbol(s)
C	A61M 5/00	A61M 5/00, A61M 5/009, A61M 5/0091
D	A61M 2005/14256	<administrative transfer to A61M 2005/1426 and A61M 2005/14252 simultaneously >
D	A61M 2005/16863	<administrative transfer to A61M 5/16863>
D	A61M 2005/16868	<administrative transfer to A61M 5/16863>
D	A61M 2005/16872	<administrative transfer to A61M 5/16863>
D	A61M 2005/206	<administrative transfer to A61M 5/206>
C	A61M 5/31	A61M 5/31, A61M 5/3147
C	A61M 2005/3125	A61M 2005/3125, A61M 5/3147
C	A61M 2005/3126	A61M 2005/3126, A61M 5/3155, A61M 5/009, A61M 5/0091
C	A61M 5/3137	A61M 5/3137, A61M 5/3147
C	A61M 2005/3139	A61M 2005/3139, A61M 5/3147
C	A61M 5/3155	A61M 5/3155, A61M 5/009, A61M 5/0091
C	A61M 5/31551	A61M 5/31551, A61M 5/009, A61M 5/0091
C	A61M 5/31553	A61M 5/31553, A61M 5/009, A61M 5/0091
D	A61M 2005/31598	<administrative transfer to A61M 5/31598>
C	A61M 5/3202	A61M 5/3202, A61M 5/32021, A61M 5/32023, A61M 5/320231, A61M 5/320233, A61M 5/320235, A61M 5/32025, A61M 5/320253, A61M 5/320255, A61M 5/32027, A61M 5/32029
C	A61M 5/3204	A61M 5/3204, A61M 5/32021, A61M 5/32023, A61M 5/320231, A61M 5/320233, A61M 5/320235, A61M 5/32025, A61M 5/320253, A61M 5/320255, A61M 5/32027, A61M 5/32029
D	A61M 2039/1033	<administrative transfer to A61M 39/1033>
D	A61M 2039/229	<administrative transfer to A61M 39/229>

* C = entries with modified file scope where reclassification of documents from the entries is involved; Q = new entries which are firstly populated with documents via administrative transfers from deleted (D) entries. Afterwards, the transferred documents into the Q entry will either stay or be moved to more appropriate entries, as determined by intellectual reclassification; D = deleted entries; F = frozen entries will be deleted once reclassification of documents from the entries is completed.

NOTES:

- Only C, D, F, and Q type entries are included in the table above.
- When multiple symbols are included in the “To” column, do not use ranges of symbols.
- For administrative transfer of documents, the following text should be used: “< administrative transfer to XX>”, “<administrative transfer to XX and YY simultaneously>”, or “<administrative transfer to XX, YY, ...and ZZ simultaneously>” when administrative transfer of the same documents is to more than one place.
- Administrative transfer to main trunk groups is assumed to be the source allocation type, unless otherwise indicated.
- Administrative transfer to 2000/Y series groups is assumed to be “additional information”.
- If needed, instructions for allocation type should be indicated within the angle brackets using the abbreviations “ADD” or “INV”: <administrative transfer to XX ADD>, <administrative transfer to XX INV>, or < administrative transfer to XX ADD, YY INV, ... and ZZ ADD simultaneously>.
- In certain situations, the “D” entries of 2000-series or Y-series groups may not require a destination (“To”) symbol, however it is required to specify “<no transfer>” in the “To” column for such cases.
- RCL is not needed for finalisation projects.

CPC NOTICE OF CHANGES 1933

DATE: AUGUST 1, 2026

PROJECT RP11946

4. CHANGES TO THE CPC-TO-IPC CONCORDANCE LIST (CICL)

<u>CPC</u>	<u>IPC</u>	<u>Action*</u>
A61M 5/009	A61M 5/00	NEW
A61M 5/0091	A61M 5/00	NEW
A61M 2005/14256		DELETE
A61M 5/16863	A61M 5/168	NEW
A61M 2005/16863		DELETE
A61M 2005/16868		DELETE
A61M 2005/16872		DELETE
A61M 2005/206		DELETE
A61M 5/206	A61M 5/20	NEW
A61M 5/3147	A61M 5/31	NEW
A61M 5/31598	A61M 5/315	NEW
A61M 2005/31598		DELETE
A61M 5/32021	A61M 5/32	NEW
A61M 5/32023	A61M 5/32	NEW
A61M 5/320231	A61M 5/32	NEW
A61M 5/320233	A61M 5/32	NEW
A61M 5/320235	A61M 5/32	NEW
A61M 5/32025	A61M 5/32	NEW
A61M 5/320253	A61M 5/32	NEW
A61M 5/320255	A61M 5/32	NEW
A61M 5/32027	A61M 5/32	NEW
A61M 5/32029	A61M 5/32	NEW
A61M 39/1033	A61M 39/10	NEW
A61M 2039/1033		DELETE
A61M 39/229	A61M 39/22	NEW
A61M 2039/229		DELETE

*Action column:

- For an (N) or (Q) entry, provide an IPC symbol and complete the Action column with “NEW.”
- For an existing CPC main trunk entry or indexing entry where the existing IPC symbol needs to be changed, provide an updated IPC symbol and complete the Action column with “UPDATED.”
- For a (D) CPC entry or indexing entry complete the Action column with “DELETE.” IPC symbol does not need to be included in the IPC column.
- For an (N) 2000 series CPC entry which is positioned within the main trunk scheme (breakdown code) provide an IPC symbol and complete the action column with “NEW”.
- For an (N) 2000 series CPC entry positioned at the end of the CPC scheme (orthogonal code), with no IPC equivalent, complete the IPC column with “CPCONLY” and complete the action column with “NEW”.

NOTES:

- F symbols are not included in the CICL table above.
- T and M symbols are not included in the CICL table above unless a change to the existing IPC is desired.

CPC NOTICE OF CHANGES 1933

DATE: AUGUST 1, 2026

PROJECT RP11946

5. CROSS-REFERENCE LIST (CRL)

Scheme references impacted by this revision project

<u>Location of reference to be changed</u>	<u>Referenced subclass or group to be changed</u>	<u>Action; New reference symbol; New text</u>
A61M 25/0097	A61M 39/10	tube connectors or tube couplings

Definitions references impacted by this revision project

<u>Location of reference to be changed</u>	<u>Referenced subclass or group to be changed</u>	<u>Section of definition</u>	<u>Action; New reference symbol; New text</u>
A61J 1/2096	A61M 39/10	Informative references	Tube connectors or tube couplings
A61M 1/3621	A61M 5/1582	Informative references	Multi-lumen needles

NOTES:

- The CRL tables above are used for changes to locations **outside** of the project scope. Changes to references in scheme titles or definitions **inside** the project scope will be reflected in the “scheme change” template or one of the “definition” templates.
- In addition to other changes proposed in the tables above, in the column titled “Referenced subclass or group to be changed,” **referenced** D symbols should indicate an action of “delete” or should indicate a replacement symbol and **referenced** F symbols should indicate a replacement symbol.
- When a reference is deleted, text related to that reference will also be deleted unless other references or a range of references associated with the same text remain.