

EUROPEAN PATENT OFFICE
U.S. PATENT AND TRADEMARK OFFICE

CPC NOTICE OF CHANGES 1550

DATE: MAY 1, 2024

PROJECT RP10450

The following classification changes will be effected by this Notice of Changes:

<u>Action</u>	<u>Subclass</u>	<u>Group(s)</u>
SCHEME:		
Symbols Deleted:	F02B	2031/003
Symbols Deleted Pending Reclassification: (frozen (F))	F02B	2031/006, 31/082
Symbols New:	F02B	31/042
Titles Changed:	F02B	31/02, 31/08
	F02B	61/045
	F02B	77/04, 77/08, 77/081
	F02B	2730/00
Indents Changed:	F02B	31/08, 31/082, 31/085, 31/087
Warnings Deleted:	F02B	SUBCLASS
Warnings New:	F02B	2031/006, 31/02, 31/04, 31/042, 31/08, 31/082, 31/085, 31/087
DEFINITIONS:		
Definitions Modified:	F02B	1/00, 1/02, 1/04, 1/12
	F02B	3/04, 3/08, 3/10
	F02B	5/02
	F02B	9/08
	F02B	11/00
	F02B	13/00
	F02B	15/00
	F02B	17/00
	F02B	21/00
	F02B	23/00
	F02B	29/00
	F02B	33/04, 33/08, 33/12, 33/14, 33/18, 33/20, 33/22, 33/26, 33/38, 33/40, 33/42
	F02B	35/02
	F02B	37/013, 37/16, 37/18, 37/183, 37/186, 37/225, 37/24
	F02B	39/005
	F02B	39/12, 39/14
	F02B	41/06, 41/08
	F02B	43/00, 43/10
	F02B	45/00, 45/02
	F02B	47/00, 47/02, 47/06, 47/08, 47/10
	F02B	49/00
	F02B	51/00, 51/02, 51/04, 51/06
	F02B	53/00
	F02B	55/10

CPC NOTICE OF CHANGES 1550

DATE: MAY 1, 2024

PROJECT RP10450

<u>Action</u>	<u>Subclass</u>	<u>Group(s)</u>
	F02B	57/00, 57/02
	F02B	61/02, 61/04, 61/045, 61/06
	F02B	63/00, 63/04
	F02B	65/00
	F02B	67/06, 67/10
	F02B	69/00
	F02B	71/00
	F02B	73/00
	F02B	75/002, 75/005, 75/007, 75/04, 75/041, 75/044, 75/047, 75/065, 75/08, 75/1896, 75/20, 75/22, 75/221, 75/222, 75/224, 75/225, 75/227, 75/228, 75/243, 75/246, 75/26, 75/265, 75/28, 75/282, 75/285, 75/287, 75/30, 75/32, 75/34, 75/36, 75/38, 75/40
	F02B	77/04, 77/08, 77/081, 77/082, 77/083, 77/084, 77/085, 77/086, 77/088, 77/089, 77/10, 77/14

No other subclasses/groups are impacted by this Notice of Changes.

This Notice of Changes includes the following [Check the ones included]:

1. CLASSIFICATION SCHEME CHANGES

- A. New, Modified or Deleted Group(s)
- B. New, Modified or Deleted Warning(s)
- C. New, Modified or Deleted Note(s)
- D. New, Modified or Deleted Guidance Heading(s)

2. DEFINITIONS

- A. New or Modified Definitions (Full definition template)
- B. Modified or Deleted Definitions (Definitions Quick Fix)

3. REVISION CONCORDANCE LIST (RCL)

4. CHANGES TO THE CPC-TO-IPC CONCORDANCE LIST (CICL)

5. CHANGES TO THE CROSS-REFERENCE LIST (CRL)

CPC NOTICE OF CHANGES 1550

DATE: MAY 1, 2024

PROJECT RP10450

1. CLASSIFICATION SCHEME CHANGES

A. New, Modified or Deleted Group(s)

SUBCLASS F02B - INTERNAL-COMBUSTION PISTON ENGINES; COMBUSTION ENGINES IN GENERAL

<u>Type*</u>	<u>Symbol</u>	<u>Indent Level Number of dots (e.g. 0, 1, 2)</u>	<u>Title</u> <u>“CPC only” text should normally be enclosed in {curly brackets}**</u>	<u>Transferred to#</u>
D	F02B2031/003	1	{with an auxiliary intake conduit starting upstream of personally controlled throttle valve and ending upstream of and close to the intake valve, or with an auxiliary intake conduit being an independent passage, e.g. having its own carburettor}	<administrative transfer to F02B31/08 INV>
F	F02B2031/006	1	{having multiple air intake valves}	F02B31/085, F02B31/087
C	F02B31/02	1	in engines having inlet valves arranged eccentrically to cylinder axis (F02B 31/08 takes precedence)	F02B31/02, F02B31/042, F02B 31/08, F02B 31/085, F02B 31/087
C	F02B31/04	1	by means within the induction channel, e.g. deflectors	F02B31/04, F02B31/042
N	F02B31/042	2	{induction channel having a helical shape around the intake valve axis}	
U	F02B31/06	2	Movable means, e.g. butterfly valves	
T	F02B31/08	1	having multiple air inlets	
F	F02B31/082	2	{the main passage having a helical shape around the intake valve axis; Engines characterised by provision of driven charging or scavenging pumps (introducing fuel into cylinders by air-pressure F02B 13/00; after-charging F02B 29/06; arrangements of such pumps or other auxiliary apparatus on engines F02B 67/00; combined engine pump control, control dependent on variables other than those generic to pump F02D)}	F02B31/08 F02B31/042
T	F02B31/085	2	{having two inlet valves}	
T	F02B31/087	2	{having three or more inlet valves}	
M	F02B61/045	2	{for marine engines}	

CPC NOTICE OF CHANGES 1550

DATE: MAY 1, 2024

PROJECT RP10450

Type*	Symbol	Indent Level Number of dots (e.g. 0, 1, 2)	Title “CPC only” text should normally be enclosed in {curly brackets}**	Transferred to#
M	F02B 77/04	1	Cleaning of, preventing corrosion or erosion in, or preventing unwanted deposits in, combustion engines	
M	F02B 77/08	1	Safety, indicating, or supervising devices (thermal insulation F02B 77/11; monitoring or diagnostic devices for exhaust-gas treatment apparatus F01N 11/00)	
M	F02B 77/081	2	{relating to endless members}	
M	F02B 2730/00	0	Internal-combustion engines with pistons rotating or oscillating with relation to the housing	

*N = new entries where reclassification into entries is involved; C = entries with modified file scope where reclassification of documents from the entries is involved; Q = new entries which are firstly populated with documents via administrative transfers from deleted (D) entries. Afterwards, the transferred documents into the Q entry will either stay or be moved to more appropriate entries, as determined by intellectual reclassification; T = existing entries with enlarged file scope, which receive documents from C or D entries, e.g. when a limiting reference is removed from the entry title; M = entries with no change to the file scope (no reclassification); D = deleted entries; F = frozen entries will be deleted once reclassification of documents from the entries is completed; U = entries that are unchanged.

NOTES:

- **No {curly brackets} are used for titles in CPC only subclasses, e.g. C12Y, A23Y; 2000 series symbol titles of groups found at the end of schemes (orthogonal codes); or the Y section titles. The {curly brackets} are used for 2000 series symbol titles found interspersed throughout the main trunk schemes (breakdown codes).
- U groups: it is obligatory to display the required “anchor” symbol (U group), i.e. the entry immediately preceding a new group or an array of new groups to be created (in case new groups are not clearly subgroups of C-type groups). Always include the symbol, indent level and title of the U group in the table above.
- All entry types should be included in the scheme changes table above for better understanding of the overall scheme change picture. Symbol, indent level, and title are required for all types.
- “Transferred to” column must be completed for all C, D, F, and Q type entries. F groups will be deleted once reclassification is completed.
- When multiple symbols are included in the “Transferred to” column, avoid using ranges of symbols in order to be as precise as possible.
- For administrative transfer of documents, the following text should be used: “<administrative transfer to XX>”, “<administrative transfer to XX and YY simultaneously>”, or “<administrative transfer to XX, YY, ...and ZZ simultaneously>” when administrative transfer of the same documents is to more than one place.
- Administrative transfer to main trunk groups is assumed to be the source allocation type, unless otherwise indicated.
- Administrative transfer to 2000/Y series groups is assumed to be “additional information”.
- If needed, instructions for allocation type should be indicated within the angle brackets using the abbreviations “ADD” or “INV”: <administrative transfer to XX ADD> , <administrative transfer to XX INV>, or <administrative transfer to XX ADD, YY INV, ... and ZZ ADD simultaneously>.
- In certain situations, the “D” entries of 2000-series or Y-series groups may not require a destination (“Transferred to”) symbol, however it is required to specify “<no transfer>” in the “Transferred to” column for such cases.
- For finalisation projects, the deleted “F” symbols should have <no transfer> in the “Transferred to” column.
- For more details about the types of scheme change, see CPC Guide.

CPC NOTICE OF CHANGES 1550

DATE: MAY 1, 2024

PROJECT RP10450

B. New, Modified or Deleted Warning(s)

SUBCLASS F02B - INTERNAL-COMBUSTION PISTON ENGINES; COMBUSTION ENGINES IN GENERAL

<u>Type*</u>	<u>Location</u>	<u>Old Warning</u>	<u>New/Modified Warning</u>
D	F02B	{In this subclass non-limiting references (in the sense of paragraph 39 of the Guide to the IPC) may still be displayed in the scheme.}	Delete entire warning
N	F02B 2031/006		Group F02B 2031/006 is no longer used for the classification of documents as of May 1, 2024. The content of this group is being reclassified into groups F02B 31/085 and F02B 31/087. Groups F02B 2031/006, F02B 31/085 and F02B 31/087 should be considered in order to perform a complete search.
N	F02B 31/02		Group F02B 31/02 is impacted by reclassification into groups F02B 31/042, F02B 31/08, F02B 31/085 and F02B 31/087. All groups listed in this Warning should be considered in order to perform a complete search.
N	F02B 31/04		Group F02B 31/04 is impacted by reclassification into group F02B 31/042. Groups F02B 31/04 and F02B 31/042 should be considered in order to perform a complete search.
N	F02B 31/042		Group F02B 31/042 is incomplete pending reclassification of documents from groups F02B 31/02, F02B 31/04 and F02B 31/082. All groups listed in this Warning should be considered in order to perform a complete search.
N	F02B 31/08		Group F02B 31/08 is incomplete pending reclassification of documents from groups F02B 31/02 and F02B 31/082. Groups F02B 31/02, F02B 31/082 and F02B 31/08 should be considered in order to perform a complete search.
N	F02B 31/082		Group F02B 31/082 is no longer used for the classification of documents as of May 1, 2024. The content of this group is being reclassified into groups F02B 31/08 and F02B 31/042. Groups F02B 31/082, F02B 31/08 and F02B 31/042 should be considered in order to perform a complete search.

CPC NOTICE OF CHANGES 1550

DATE: MAY 1, 2024

PROJECT RP10450

<u>Type*</u>	<u>Location</u>	<u>Old Warning</u>	<u>New/Modified Warning</u>
N	F02B 31/085		Group F02B 31/085 is incomplete pending reclassification of documents from groups F02B 2031/006 and F02B 31/02. Groups F02B 2031/006, F02B 31/02 and F02B 31/085 should be considered in order to perform a complete search.
N	F02B 31/087		Group F02B 31/087 is incomplete pending reclassification of documents from groups F02B 2031/006 and F02B 31/02. Groups F02B 2031/006, F02B 31/02 and F02B 31/087 should be considered in order to perform a complete search.

*N = new warning, M = modified warning, D = deleted warning

NOTE: The "Location" column only requires the symbol PRIOR to the location of the warning. No further directions such as "before" or "after" are required.

DATE: MAY 1, 2024

PROJECT RP10450

2. A. DEFINITIONS (modified)

F02B1/00

Delete: The last sentence of the Definition statement so that the updated statement appears as follows.

Definition statement

This place covers:

Engine working on the compression of a homogeneous mixture of air and fuel.

F02B1/02

Replace: The existing Definition statement text with the following updated text.

Definition statement

This place covers:

Engines with positive ignition, e.g. gasoline or petrol engines.

References

Insert: The following new Limiting references section.

Limiting references

This place does not cover:

Engines with non-timed positive ignition	F02B9/06
--	----------

DATE: MAY 1, 2024

PROJECT RP10450

F02B1/04

References

Delete: The entire Limiting references section.

Insert: The following new Informative references section.

Informative references

Attention is drawn to the following places, which may be of interest for search:

Direct injection petrol engines	F02B2075/125
---------------------------------	------------------------------

F02B1/12

Replace: The existing Definition statement text with the following updated text.

Definition statement

This place covers:

Engines operating with compression ignition of "homogeneous" mixed air-fuel.

References

Insert: The following new Limiting references section.

Limiting references

This place does not cover:

With fuel-air charge ignited by compression ignition of an additional fuel	F02B7/00
--	--------------------------

DATE: MAY 1, 2024

PROJECT RP10450

F02B3/04

References

Delete: The entire Limiting references section.

Insert: The following new Informative references section.

Informative references

Attention is drawn to the following places, which may be of interest for search:

Controlling combustion engines	F02D
Electrical control of combustion engines	F02D41/00

F02B3/08

Replace: The existing Definition statement with the following updated statement. The image should be deleted.

Definition statement

This place covers:

Methods of operating which would be a deviation from the “normal” diesel cycle. Usually, the method of operating is already embodied in the engine itself.

References

Replace: The existing Limiting references table with the following updated table.

Limiting references

This place does not cover:

Methods of operating compression ignition engines with intermittent fuel introduction	F02B3/12
---	--------------------------

DATE: MAY 1, 2024

PROJECT RP10450

Insert: The following new Informative references section.

Informative references

Attention is drawn to the following places, which may be of interest for search:

Control of combustion engines	F02D
-------------------------------	----------------------

F02B3/10

Replace: The existing Definition statement text with the following updated text.

Definition statement

This place covers:

Compression ignition engines where more than one injection per cycle or very closely spaced multiple injections are introduced.

References

Delete: The entire Limiting references section.

Insert: The following new Informative references section.

Informative references

Attention is drawn to the following places, which may be of interest for search:

Controlling fuel injection of the high-pressure type with multiple injections	F02D41/402
Fuel injection apparatus with each cyclic delivery being separated into two or more parts	F02M45/02

F02B5/02

References

Delete: The entire Limiting references section.

Insert: The following new Informative references section.

Informative references

Attention is drawn to the following places, which may be of interest for search:

Control of combustion engines	F02D
-------------------------------	------

F02B9/08

Insert: The following new Definition statement.

Definition statement

This place covers:

Illustrative example of subject matter classified in this place:

Hot bulb engine

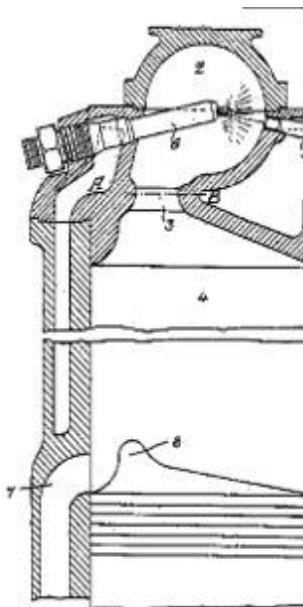

Delete: The entire Special rules of classification section.

F02B11/00

Replace: The existing Definition statement with the following updated statement.

Definition statement

This place covers:

Engines characterised by both fuel-air mixture compression and air compression, or characterised by both positive ignition and compression ignition, e.g. in different cylinders.

This place also covers engines characterised by spark-assisted compression ignition, in which a spark ignition triggers an instantaneous compression ignition.

Illustrative example of subject matter classified in this place:

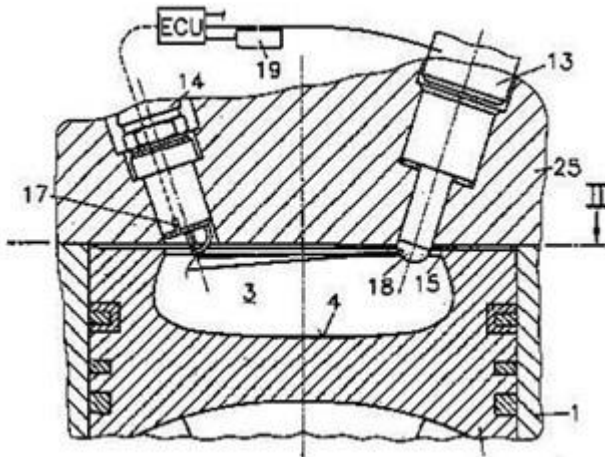

Insert: The following new Synonyms and Keywords section.

Synonyms and Keywords

In patent documents, the following abbreviations are often used:

SPCCI	Spark Controlled Compression Ignition
-------	---------------------------------------

DATE: MAY 1, 2024

PROJECT RP10450

F02B13/00

Replace: The existing Definition statement text with the following updated text.

Definition statement

This place covers:

Engines characterised by the introduction of liquid fuel into cylinders by use of an auxiliary fluid, e.g. using compressed air or gas for blowing fuel into combustion chamber.

References

Insert: The following new reference in the Informative references table.

Informative references

Attention is drawn to the following places, which may be of interest for search:

Characterised by use of gaseous or solid fuels	F02B 43/00, F02B 45/00
--	---------------------------

F02B15/00

Replace: The existing Definition statement text with the following updated text.

Definition statement

This place covers:

This group covers exceptional cases of engines with fuel introduction into cylinder that cannot be classified elsewhere.

References

Replace: The existing Informative references table with the following updated table.

Informative references

DATE: MAY 1, 2024

PROJECT RP10450

Attention is drawn to the following places, which may be of interest for search:

Characterised by use of gaseous or solid fuels	F02B 43/00, F02B 45/00
Direct injection	F02B2075/125

F02B17/00

Replace: The existing Definition statement text with the following updated text.

Definition statement

This place covers:

Engines characterised by means for effecting stratification of charge in cylinders.

In a stratified charge engine, the fuel air mixture is stratified, i.e. heterogeneous, e.g. with a richer mixture near a spark plug than elsewhere.

Replace: The existing Relationships text with the following updated text.

Relationships with other classification places

Classification in this group is limited to the technical features of the engine for making stratification of charge possible.

Controlling fuel injection is classified in [F02D](#).

References

Delete: The entire Limiting references section.

Insert: The following new reference in the Informative references table.

Informative references

Attention is drawn to the following places, which may be of interest for search:

DATE: MAY 1, 2024

PROJECT RP10450

Engines with air compression and subsequent fuel addition	F02B3/00
---	--------------------------

Delete: The entire Special rules of classification section.

F02B21/00

Replace: The existing Definition statement text with the following updated text.

Definition statement

This place covers:

Engines with an auxiliary air chamber, e.g. which may be connected and disconnected with the engine intake or cylinder during the compression or expansion period of the engine cycle in order to influence the compression or expansion process.

Delete: The entire Relationships section.

References

Delete: The entire Limiting references section.

Insert: The following five new references in the Informative references table.

Informative references

Attention is drawn to the following places, which may be of interest for search:

Air hybrid prime movers	B60K6/08
Compressed air driven engines	F01B29/08
Engines characterised by provision for charging or scavenging not provided for in groups F02B 25/00, F02B 27/00 or F02B 33/00-F02B 39/00	F02B29/00
Engines characterised by provision of pumps for charging or scavenging	F02B33/00
Using engine as a brake by varying inlet or exhaust valve operation	F02D13/04

DATE: MAY 1, 2024

PROJECT RP10450

Delete: The entire Special rules section.

F02B23/00

Replace: The existing Definition statement text with the following updated text.

Definition statement

This place covers:

Engines characterised by a special shape of the combustion chamber to improve operation. The shape of the combustion space between the cylinder head and the working piston determines how the combustible mixture of air and fuel is combusted. The group mainly deals with the configuration of the combustion space in the piston for compression ignition but also for spark ignited engines.

Delete: The entire Relationships section.

References

Delete: The following three references from the Limiting references table.

Limiting references

This place does not cover:

Cylinders	F02F1/00
Pistons	F02F3/00
Fuel injectors	F02M39/00

Replace: The existing Informative references table with the following updated table.

Informative references

Attention is drawn to the following places, which may be of interest for search:

Modifying induction systems for imparting a rotation to the charge in the cylinder	F02B31/00
Cylinders	F02F1/00

DATE: MAY 1, 2024

PROJECT RP10450

Pistons	F02F3/00
Arrangements of fuel-injection apparatus with respect to engines	F02M39/00

Replace: The existing Glossary of terms table with the following updated table.

Glossary of terms

In this place, the following terms or expressions are used with the meaning indicated:

Squish flow	Flow through a narrowing area, e.g. between piston and cylinder head
Swirl flow	Rotational flow around the cylinder axis
Tumble flow	Rotational flow around a line perpendicular to the cylinder axis

F02B29/00

Replace: The existing Definition statement text with the following updated text.

Definition statement

This place covers:

Means not otherwise provided for, for improving the engine's volumetric efficiency by increasing the air intake density. The pressure of ambient air drawn in is increased and the temperature is decreased before it enters into the engine cylinder. This results in a greater mass of air entering the cylinder on each intake stroke.

Delete: The entire Relationships section.

References

Delete: The entire Limiting references section.

Insert: The following new References out of a residual place section.

References out of a residual place

Examples of places in relation to which this place is residual:

Engines characterised by using fresh charge for scavenging cylinders	F02B 25/00
Resonance charging	F02B27/00
Pumps for charging or scavenging	F02B33/00

Engines characterised by provision of pumps for sucking combustion residues from cylinders	F02B35/00
Turbo charging	F02B37/00
Component details, or accessories relating to driven charging or scavenging pumps	F02B39/00

Delete: The entire Glossary of terms section.

F02B33/04

Insert: The following new Definition statement.

Definition statement

This place covers:

Illustrative example of subject matter classified in this place:

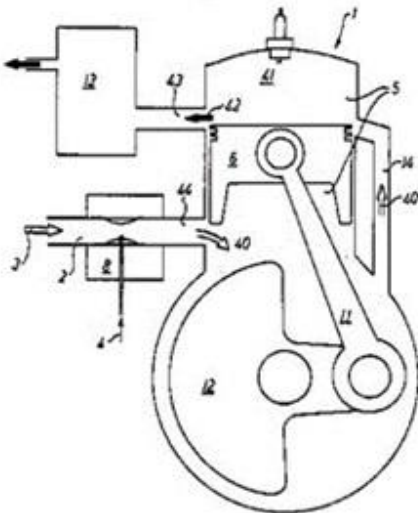

Delete: The entire References/Informative references section.

Delete: The entire Special rules section.

DATE: MAY 1, 2024

PROJECT RP10450

F02B33/08

Insert: The following new Definition statement.

Definition statement

This place covers:

Illustrative example of subject matter classified in this place:

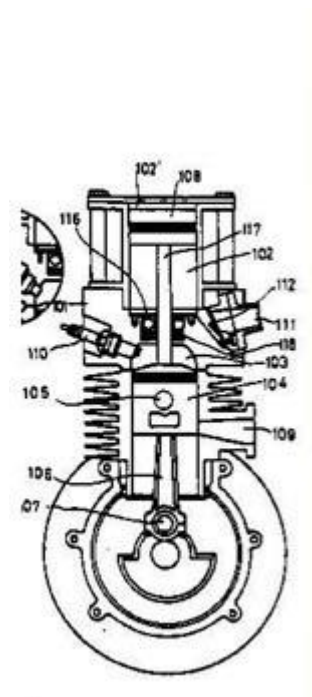

Delete: The entire Special rules section.

F02B33/12

Insert: The following new Definition statement.

Definition statement

This place covers:

Illustrative example of subject matter classified in this place:

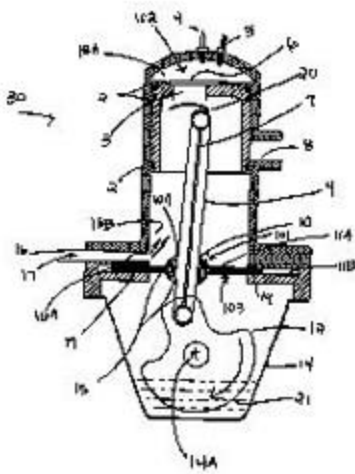

Delete: The entire Special rules section.

F02B33/14

Insert: The following new Definition statement.

Definition statement

This place covers:

Illustrative example of subject matter classified in this place:

DATE: MAY 1, 2024

PROJECT RP10450

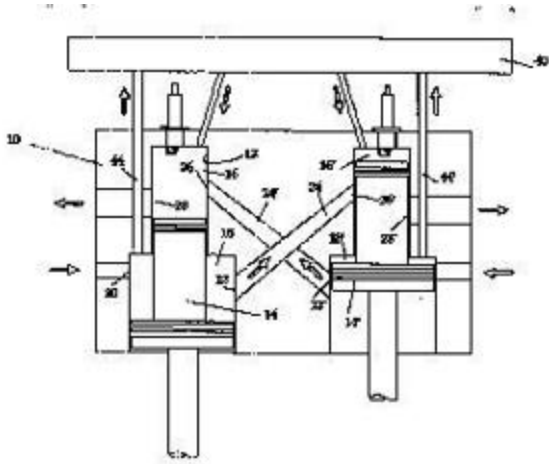

Delete: The entire Special rules section.

F02B33/18

Insert: The following new Definition statement.

Definition statement

This place covers:

Illustrative example of subject matter classified in this place:

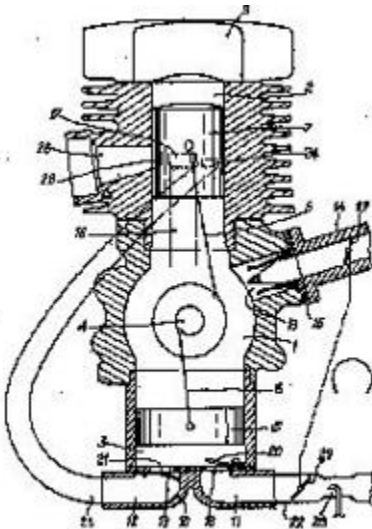

Delete: The entire Special rules section.

F02B33/20

Insert: The following new Definition statement.

Definition statement

This place covers:

Illustrative example of subject matter classified in this place:

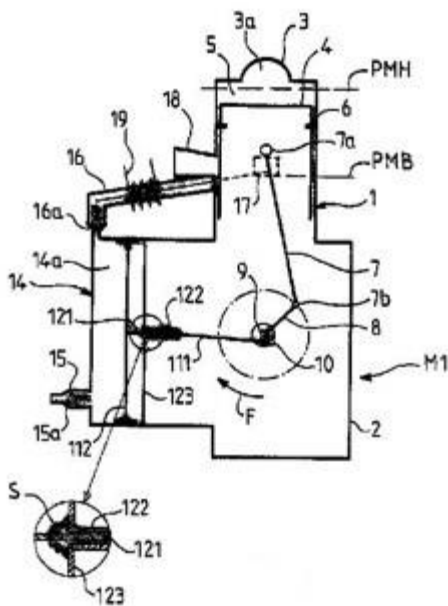

Delete: The entire Special rules section.

F02B33/22

Insert: The following new Definition statement.

Definition statement

DATE: MAY 1, 2024

PROJECT RP10450

This place covers:

Illustrative example of subject matter classified in this place:

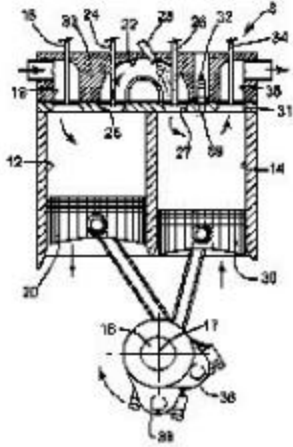

Delete: The entire Special rules section.

F02B33/26

Insert: The following new Definition statement.

Definition statement

This place covers:

Illustrative example of subject matter classified in this place:

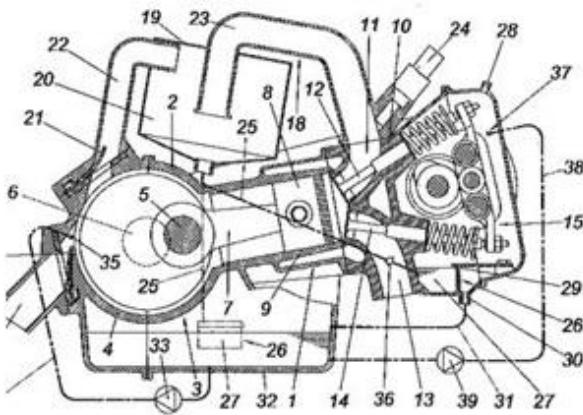

DATE: MAY 1, 2024

PROJECT RP10450

Delete: The entire Special rules section.

F02B33/38

Insert: The following new Definition statement.

Definition statement

This place covers:

Illustrative example of subject matter classified in this place:

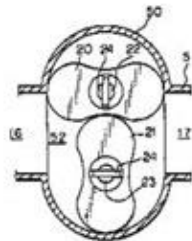
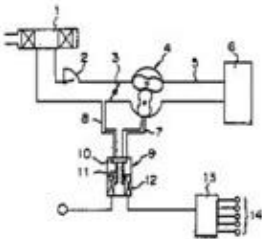

Delete: The entire Special rules section.

F02B33/40

Insert: The following new Definition statement.

Definition statement

This place covers:

Illustrative example of subject matter classified in this place:

DATE: MAY 1, 2024

PROJECT RP10450

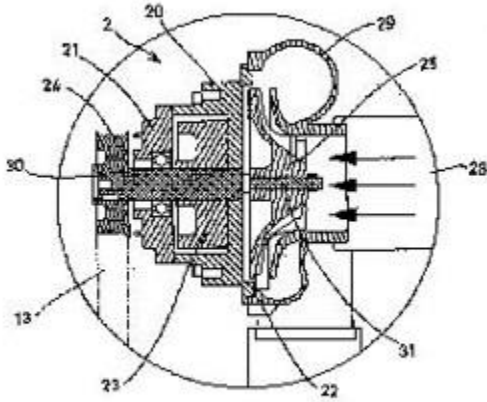

Delete: The entire Special rules section.

F02B33/42

Replace: The existing Definition statement text and image with the following updated text and image.

Definition statement

This place covers:

Engine with driven or non-driven apparatus for immediate conversion of combustion gas pressure into pressure of fresh charge, e.g. with cell-type pressure exchangers.

Illustrative example of subject matter classified in this place:

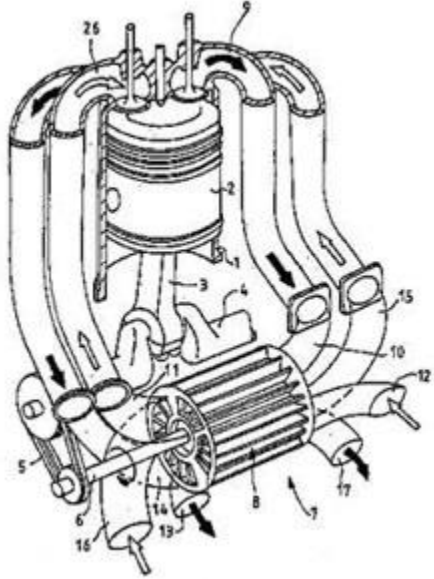

F02B35/02

Insert: The following new Definition statement.

Definition statement

This place covers:

Illustrative example of subject matter classified in this place:

CPC NOTICE OF CHANGES 1550

DATE: MAY 1, 2024

PROJECT RP10450

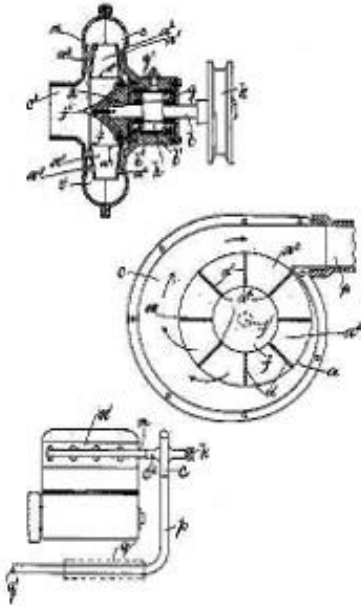

Delete: The entire Special rules section.

F02B37/013

Insert: The following new Definition statement.

Definition statement

This place covers:

Illustrative example of subject matter classified in this place:

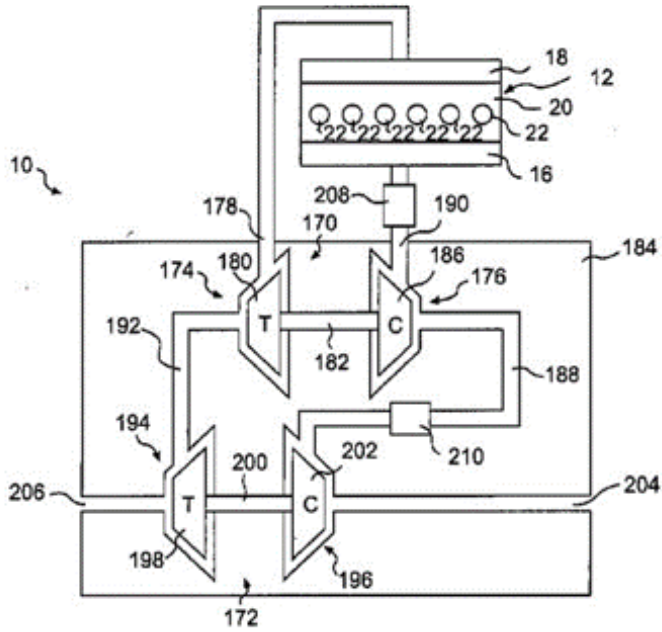

Delete: The entire Special rules section.

F02B37/16

Replace: The existing Definition statement text with the following updated text, so that the updated Definition statement appears as follows.

Definition statement

This place covers:

Illustrative example of subject matter classified in this place:

DATE: MAY 1, 2024

PROJECT RP10450

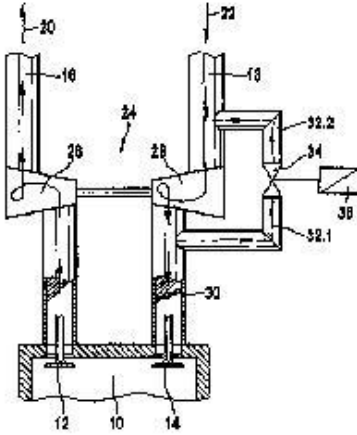

F02B37/18

Replace: The existing Definition statement text with the following updated text.

Definition statement

This place covers:

Controlling the pump by bypassing the exhaust.

References

Delete: The entire Limiting references section.

Insert: The following new reference in the Informative references table.

Informative references

Attention is drawn to the following places, which may be of interest for search:

Constructional aspects of bypass valves	F01D17/105
---	----------------------------

DATE: MAY 1, 2024

PROJECT RP10450

F02B37/183

References

Delete: The entire Limiting references section.

Replace: The existing Informative references table with the following updated table.

Informative references

Attention is drawn to the following places, which may be of interest for search:

Constructional aspects of bypass valves	F01D17/105
Valves in general	F16K
Valve actuating devices in general	F16K31/00

F02B37/186

Delete: The entire Definition statement.

References

Delete: The entire Limiting references section.

Insert: The following new Informative references section.

Informative references

Attention is drawn to the following places, which may be of interest for search:

Valve actuating devices per se	F16K31/00
--------------------------------	---------------------------

F02B37/225

References

Delete: The entire Limiting references section.

DATE: MAY 1, 2024

PROJECT RP10450

Insert: The following new Informative references section.

Informative references

Attention is drawn to the following places, which may be of interest for search:

Constructional aspects per se of such devices	F01D17/00
---	---------------------------

F02B37/24

References

Delete: The entire Limiting references section.

Insert: The following new Informative references section.

Informative references

Attention is drawn to the following places, which may be of interest for search:

Constructional aspects per se of such devices	F01D17/16
---	---------------------------

F02B39/005

Replace: The existing Definition statement with the following updated Definition statement.

Definition statement

This place covers:

Arrangement of cooling system of super/turbocharger, layout (or partial layout) of cooling fluid circuits.

Illustrative example of subject matter classified in this place:

DATE: MAY 1, 2024

PROJECT RP10450

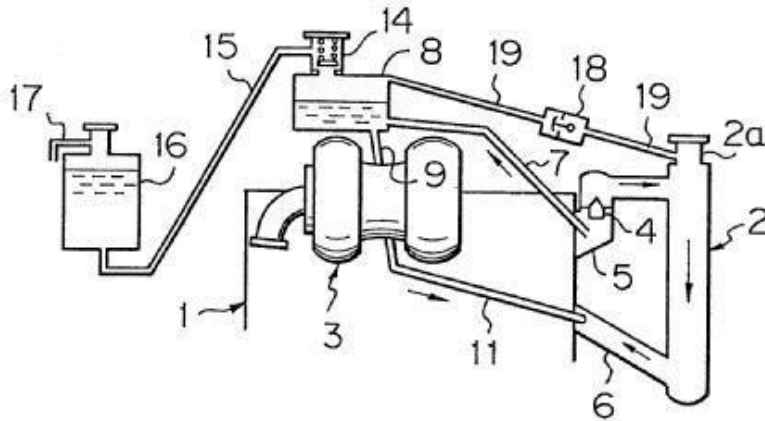

References

Delete: The entire Limiting references section.

Insert: The following new Informative references section.

Informative references

Attention is drawn to the following places, which may be of interest for search:

Turbochargers	F02C6/12
Turbocharger features related to cooling	F01D25/12
Turbocharger features related to cooling of bearings	F01D25/125
Turbocharger casings modified for cooling	F01D25/14

F02B39/12

References

Insert: The following new Limiting references section.

Limiting references

This place does not cover:

Using fluid slip couplings for varying gear ratio	F02B39/08
---	---------------------------

DATE: MAY 1, 2024

PROJECT RP10450

Delete: The entire Informative references section.

F02B39/14

Replace: The existing Definition statement text with the following updated text.

Definition statement

This place covers:

Lubrication of pumps; Safety measures therefor, e.g. arrangement of lubrication system of supercharger or turbocharger, layout (or partial layout) of lubrication fluid circuits.

References

Delete: The entire Limiting references section.

Insert: The following new Informative references section.

Informative references

Attention is drawn to the following places, which may be of interest for search:

Lubricating of machines or engines in general; Lubricating internal-combustion engines	F01M
Turbocharger lubrication per se, e.g. lubricating a turbocharger bearing per se	F01D25/18
Lubrication of bearings in general	F16C
Lubricating in general	F16N

F02B41/06

Replace: The existing Definition statement text and image with the following updated text and image.

Definition statement

This place covers:

Engines with more than one expansion stroke, i.e. the exhaust is allowed to expand in an additional cylinder. The compounding is similar to the compounding in a steam engine.

Illustrative example of subject matter classified in this place:

Valves 23 and 24 allow expansion of exhaust gases to adjacent cylinder through channels 21 and 22

1a.

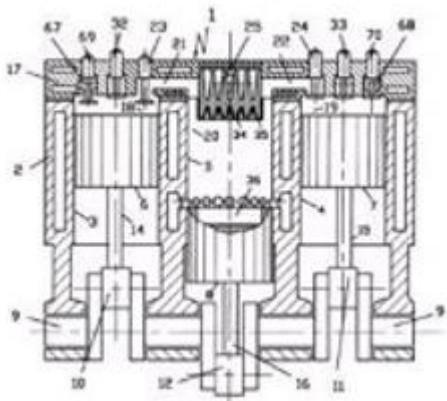

1b.

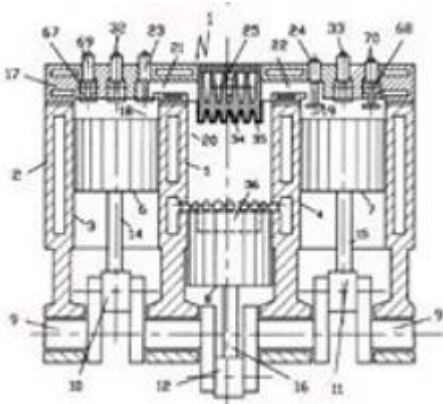

F02B41/08

Replace: The existing Definition statement text and image with the following updated text and image.

Definition statement

This place covers:

Two stroke engines with second expansion in an expansion cylinder.

Illustrative example of subject matter classified in this place:

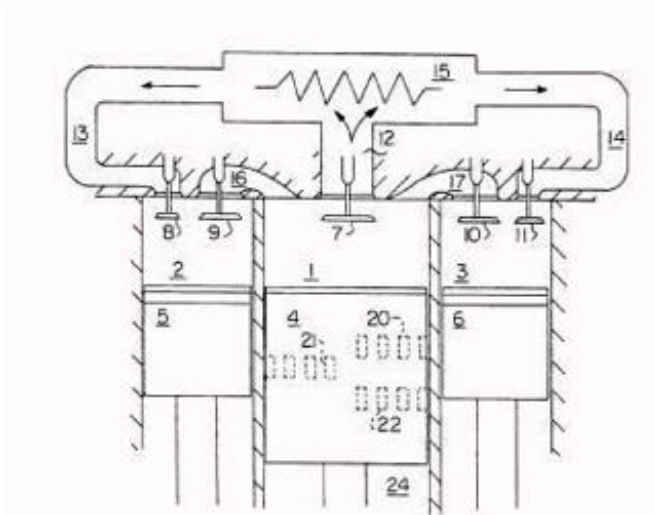

F02B43/00

Replace: The existing Definition statement text and image with the following updated text and image.

Definition statement

This place covers:

Illustrative example of subject matter classified in this place:

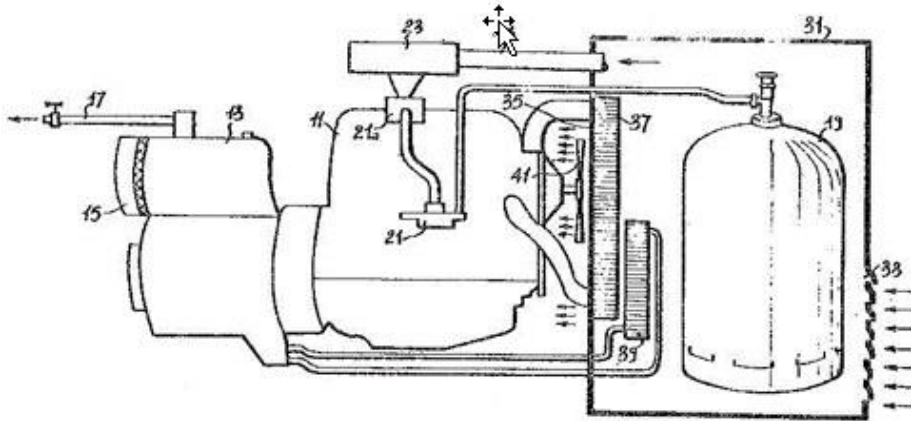

References

Delete: The following two references from the Limiting references table.

Limiting references

This place does not cover:

Control of gas supply per se	F02D19/00
Installations for supply of gas per se	F02M21/00

Replace: The existing Informative references table with the following updated table.

Informative references

Attention is drawn to the following places, which may be of interest for search:

Control of gas engines	F02D19/00
Apparatus for supplying engines with gaseous fuels	F02M21/02

Replace: The existing text for the term “LNG” with the following updated text.

Glossary of terms

In this place, the following terms or expressions are used with the meaning indicated:

CPC NOTICE OF CHANGES 1550

DATE: MAY 1, 2024

PROJECT RP10450

LNG	Liquefied Natural Gas. It behaves like an inert gas. It has a high critical compression ratio. Therefore, only used with spark ignition or pilot fuel ignition
-----	--

F02B43/10

Delete: The entire Definition statement.

References

Delete: The entire Limiting references section.

Replace: The existing Informative references table with the following updated table.

Informative references

Attention is drawn to the following places, which may be of interest for search:

Production of hydrogen	C01B3/02
Supplying engines with gaseous fuel	F02M21/02
Fuel cells per se	H01M8/00

F02B45/00

References

Insert: The following new Limiting references section.

Limiting references

This place does not cover:

Plants involving generation of gaseous fuels from solid fuel	F02B43/08
Engines convertible from gas to other fuel consumption	F02B69/04

Replace: The existing Informative references table with the following updated table.

Informative references

CPC NOTICE OF CHANGES 1550

DATE: MAY 1, 2024

PROJECT RP10450

Attention is drawn to the following places, which may be of interest for search:

Apparatus for supplying engines with non-liquid and non-gaseous fuels	F02M 21/08
---	----------------------------

F02B45/02

Replace: The existing Definition statement text with the following updated text.

Definition statement

This place covers:

Engines operating on powdered fuel, e.g. powdered coal.

References

Insert: The following new Limiting references section.

Limiting references

This place does not cover:

Operating on fuel containing oxidant	F02B45/06
--------------------------------------	---------------------------

Replace: The existing Informative references table with the following updated table.

Informative references

Attention is drawn to the following places, which may be of interest for search:

Apparatus for supplying engines with fuels in pulverised state	F02M21/12
--	---------------------------

F02B47/00

Delete: The entire Definition statement.

Insert: The following new Informative references section.

References

DATE: MAY 1, 2024

PROJECT RP10450

Informative references

Attention is drawn to the following places, which may be of interest for search:

Controlling engines characterised by use of non-fuel substances added to the combustible mixtures	F02D41/0025
Engine-pertinent apparatus for adding non-fuel substances or small quantities of secondary fuel to combustion-air, main fuel or fuel-air mixture	F02M25/00

F02B47/02

References

Delete: The entire Limiting references section.

Insert: The following new Informative references section.

Informative references

Attention is drawn to the following places, which may be of interest for search:

Apparatus for adding fuel and water emulsion, water or steam to engine	F02M25/022
--	----------------------------

F02B47/06

Replace: The existing Definition statement text and image with the following updated text and images.

Definition statement

This place covers:

The added substance including non-airborne oxygen, e.g. N₂O or laughing gas.

Illustrative examples of subject matter classified in this place:

1.

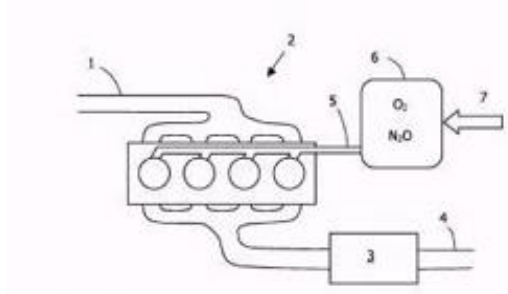

2.

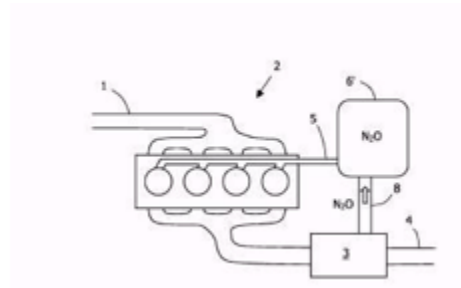

References

Delete: The following reference from the Limiting references table.

Limiting references

This place does not cover:

Apparatus for supplying non-airborne oxygen to engine	F02M25/10
---	---------------------------

Insert: The following new Informative references section.

DATE: MAY 1, 2024

PROJECT RP10450

Informative references

Attention is drawn to the following places, which may be of interest for search:

Apparatus for supplying non-airborne oxygen to engine	F02M25/10
---	---------------------------

F02B47/08

References

Delete: The entire Limiting references section.

Insert: The following new Informative references section.

Informative references

Attention is drawn to the following places, which may be of interest for search:

Apparatus for adding exhaust gas to engines, e.g. by exhaust gas recirculation [EGR] systems	F02M26/00
--	---------------------------

F02B47/10

References

Delete: The entire Limiting references section.

Insert: The following new Informative references section.

Informative references

Attention is drawn to the following places, which may be of interest for search:

Apparatus for adding exhaust gas to engine, e.g. by exhaust gas recirculation [EGR] systems	F02M26/00
---	---------------------------

DATE: MAY 1, 2024

PROJECT RP10450

F02B49/00

Replace: The existing Definition statement text and image with the following updated text and image.

Definition statement

This place covers:

Methods of operating air-compressing compression-ignition engines involving introduction of small quantities of fuel in the form of a fine mist into the air in the engine's intake, for example, as a starting aid.

Illustrative example of subject matter classified in this place:

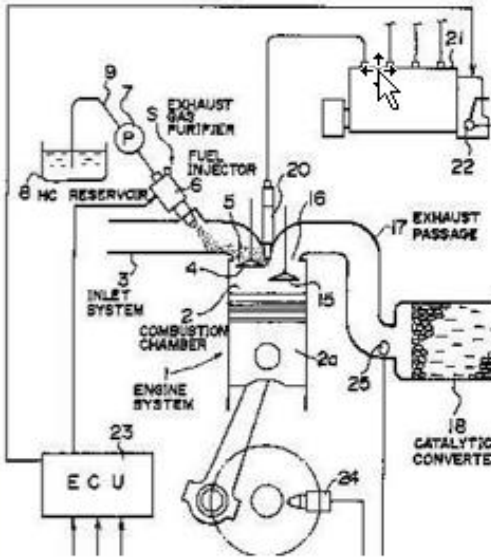

Insert: The following new Informative references section.

Informative references

Attention is drawn to the following places, which may be of interest for search:

Controlling combustion engines	F02D
Fuel injector connections to the air intake system	F02M35/10216
Low-pressure fuel-injection apparatus	F02M69/00

DATE: MAY 1, 2024

PROJECT RP10450

F02B51/00

Delete: The entire Definition statement.

References

Insert: The following two new references in the Informative references table.

Informative references

Attention is drawn to the following places, which may be of interest for search:

Controlling combustion engines	F02D
Apparatus for performing such pretreatments or additions	F02M

F02B51/02

References

Delete: The entire Limiting references section.

Insert: The following new Informative references section.

Informative references

Attention is drawn to the following places, which may be of interest for search:

Apparatus for treating combustion-air, fuel or fuel-air mixture by catalyst	F02M27/02
---	-----------

F02B51/04

References

Delete: The entire Limiting references section.

Insert: The following new Informative references section.

Informative references

Attention is drawn to the following places, which may be of interest for search:

CPC NOTICE OF CHANGES 1550

DATE: MAY 1, 2024

PROJECT RP10450

Apparatus for treating combustion-air, fuel or fuel-air mixture by electric means or magnetism	F02M27/04
--	-----------

F02B51/06

References

Delete: The entire Limiting references section.

Insert: The following new Informative references section.

Informative references

Attention is drawn to the following places, which may be of interest for search:

Apparatus for treating combustion-air, fuel or fuel-air mixture by sonic or ultrasonic waves	F02M27/08
--	-----------

F02B53/00

References

Insert: The following new Limiting references section.

Limiting references

This place does not cover:

Internal combustion aspects of rotary pistons or outer members of co-operating therewith	F02B55/00
--	-----------

Delete: The following reference from the Informative references table.

Informative references

DATE: MAY 1, 2024

PROJECT RP10450

Attention is drawn to the following places, which may be of interest for search:

Internal combustion aspects of rotary pistons or outer members of co-operating therewith	F02B55/00
--	-----------

F02B55/10

Insert: The following new Definition statement.

Definition statement

This place covers:

Illustrative examples of subject matter classified in this place:

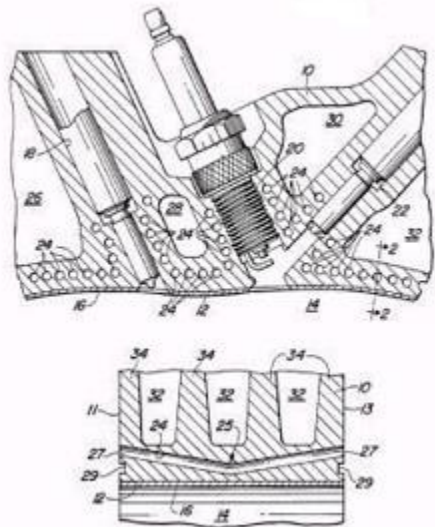

Delete: The entire Special rules section.

F02B57/00

Replace: The existing Definition statement text and image with the following updated text and image.

Definition statement

This place covers:

Illustrative example of subject matter classified in this place:

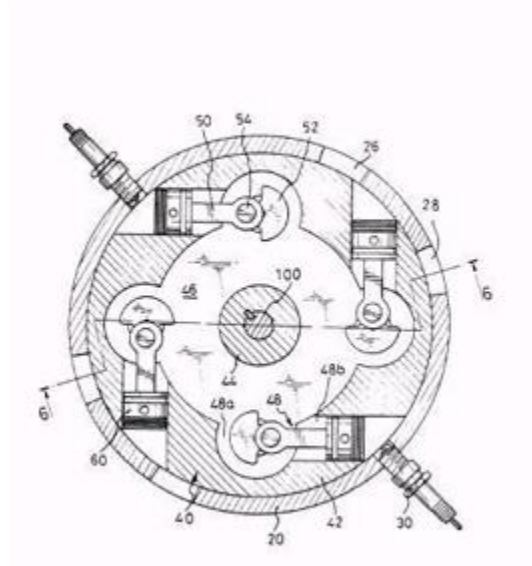

F02B57/02

References

Insert: The following new Limiting references section.

Limiting references

This place does not cover:

Cylinder-charge admission of exhaust control	F02B57/04
--	-----------

Delete: The entire Informative references section.

F02B61/02

Replace: The existing Definition statement text and image with the following updated text and image.

Definition statement

This place covers:

Engines specially adapted for driving cycles, e.g. motorcycles.

Illustrative example of subject matter classified in this place:

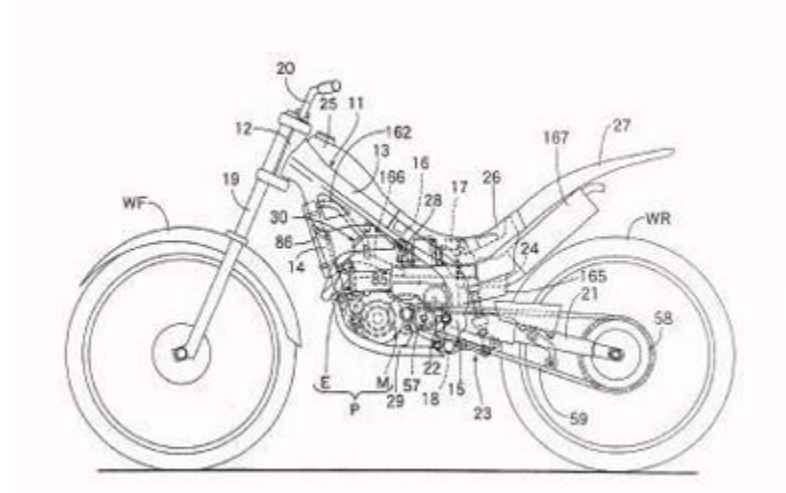

F02B61/04

Replace: The existing Definition statement text and image with the following updated text and image.

Definition statement

This place covers:

Engines specially adapted for driving propellers, e.g. aircraft propellers.

Illustrative example of subject matter classified in this place:

DATE: MAY 1, 2024

PROJECT RP10450

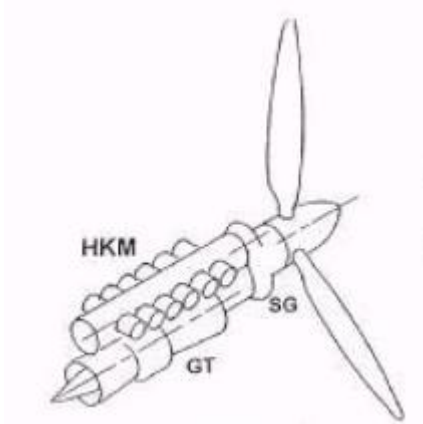

F02B61/045

Replace: The existing Definition statement text and image with the following updated text and image.

Definition statement

This place covers:

Engines specially adapted for driving propellers of outboard marine engines, inboard marine engines, personal water craft engines.

Illustrative example of subject matter classified in this place:

CPC NOTICE OF CHANGES 1550

DATE: MAY 1, 2024

PROJECT RP10450

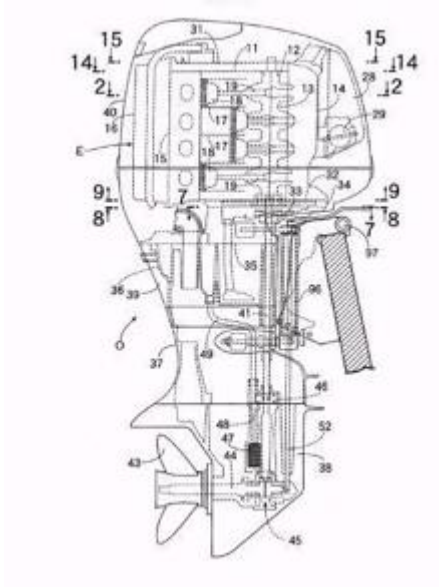

F02B61/06

Replace: The existing Definition statement text and image with the following updated text and image.

Definition statement

This place covers:

Illustrative example of subject matter classified in this place:

CPC NOTICE OF CHANGES 1550

DATE: MAY 1, 2024

PROJECT RP10450

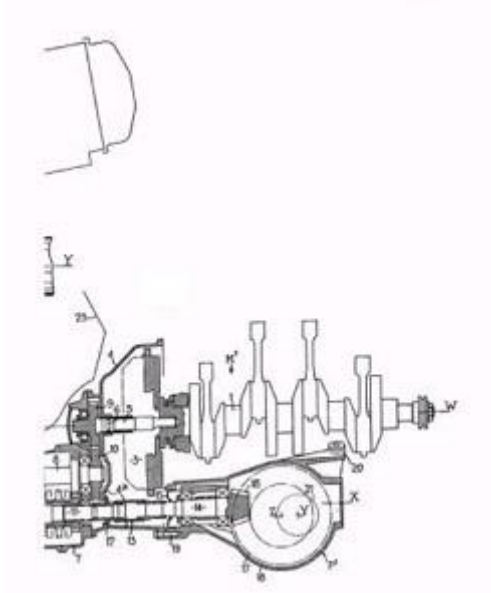

F02B63/00

Delete: The entire Definition statement.

F02B63/04

Replace: The existing Definition statement text and image with the following updated text and image.

Definition statement

This place covers:

Illustrative example of subject matter classified in this place:

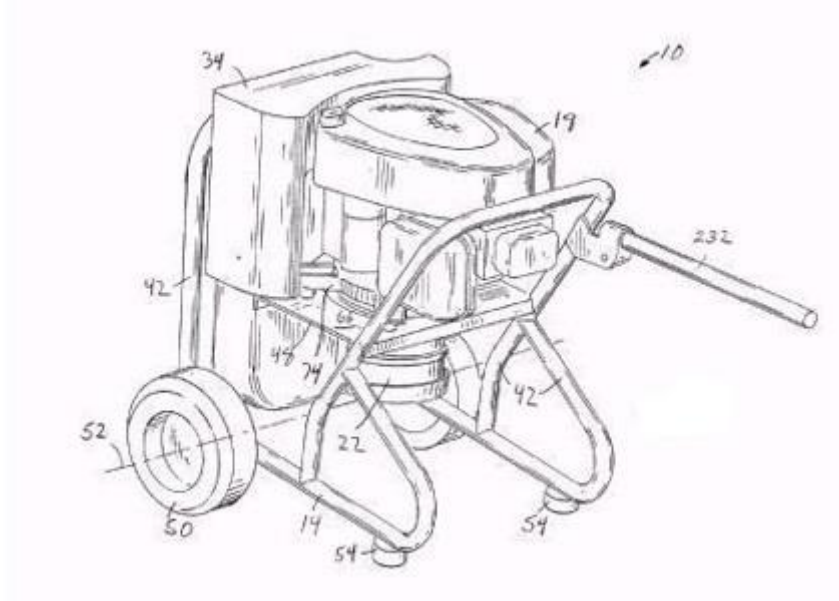

F02B65/00

Replace: The existing Definition statement text with the following updated text.

Definition statement

This place covers:

Adaptations of engines for special uses not provided for in groups [F02B61/00](#) or [F02B63/00](#); Combinations of engines with other devices, e.g. with non-driven apparatus. For example, internal combustion engines where an engine cylinder may act as an air compressor.

F02B67/06

Replace: The existing Definition statement text and image with the following updated text and image.

Definition statement

This place covers:

Auxiliary devices driven by means of chains, belts, or like endless members.

Illustrative example of subject matter classified in this place:

DATE: MAY 1, 2024

PROJECT RP10450

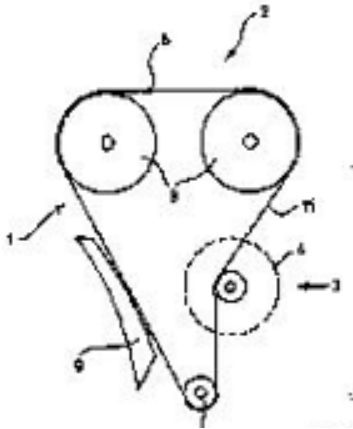

F02B67/10

Replace: The existing Definition statement text and image with the following updated text and image.

Definition statement

This place covers:

Engines characterised by the arrangement charging or scavenging apparatus, e.g. driving arrangement or mounting arrangement. Also, for particular positioning with respect to engine.

Illustrative example of subject matter classified in this place:

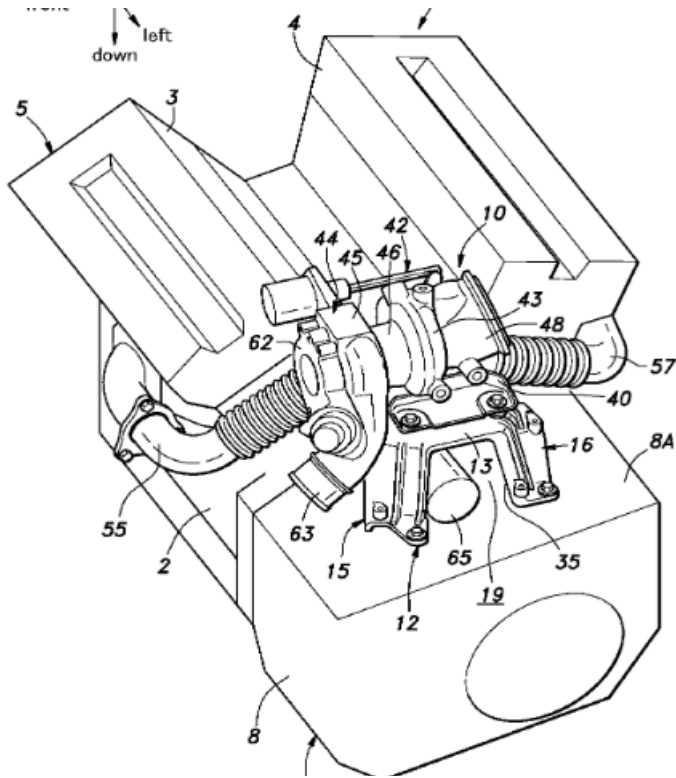

F02B69/00

Replace: The existing Definition statement text with the following updated text.

Definition statement

This place covers:

Internal combustion engines convertible into other combustion-engine type not provided for in F02B11/00; Internal-combustion engines of different types characterised by constructions facilitating use of same main engine-parts in different types.

For example, engines convertible from two stroke to four stroke, or convertible for use with different fuels.

References

Delete: The entire Limiting references section.

Insert: The following new References out of a residual place section.

References out of a residual place

Examples of places in relation to which this place is residual:

Engines characterised by both fuel-air mixture compression and air compression, or characterised by both positive ignition and compression ignition, e.g. in different cylinders	F02B11/00
--	-----------

F02B71/00

Replace: The existing Definition statement text and image with the following updated text and image.

Definition statement

This place covers:

Illustrative example of subject matter classified in this place:

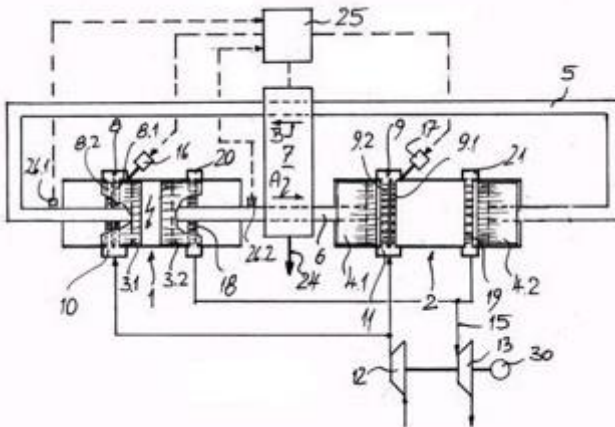

F02B73/00

Replace: The existing Definition statement text and image with the following updated text and image.

Definition statement

This place covers:

E.g. combining two or more engines, not otherwise provided for. For example, of the same or different type, e.g. an internal combustion engine and a Stirling engine.

Illustrative examples of subject matter classified in this place:

1.

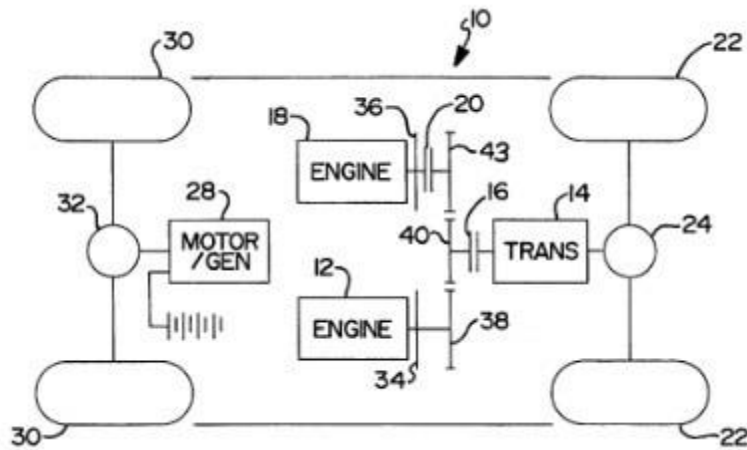

2.

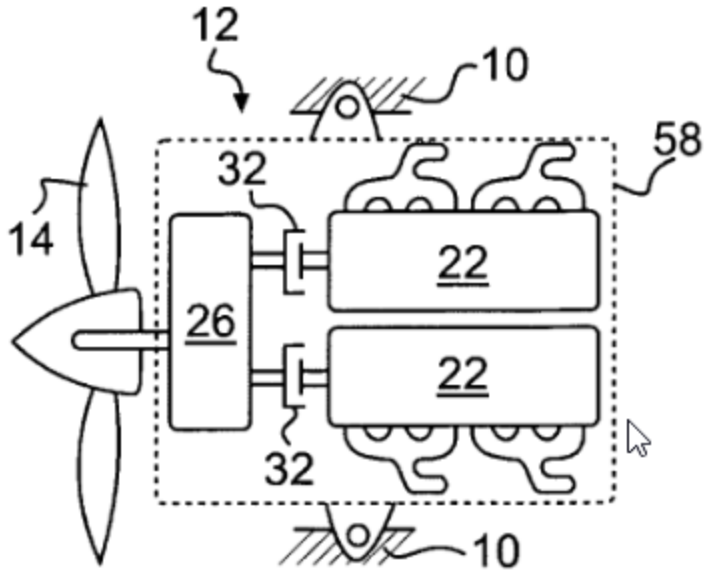

Insert: The following new References out of a residual place section.

References

References out of a residual place

Examples of places in relation to which this place is residual:

Controlling two or more co-operating engines	F02D25/00
--	---------------------------

F02B75/002

Replace: The existing Definition statement text and image with the following updated text and image.

Definition statement

This place covers:

Illustrative example of subject matter classified in this place:

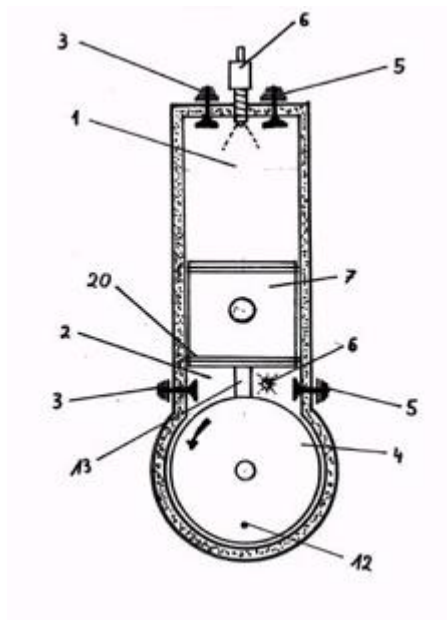

F02B75/005

Replace: The existing Definition statement text and image with the following updated text and image.

Definition statement

This place covers:

Illustrative example of subject matter classified in this place:

CPC NOTICE OF CHANGES 1550

DATE: MAY 1, 2024

PROJECT RP10450

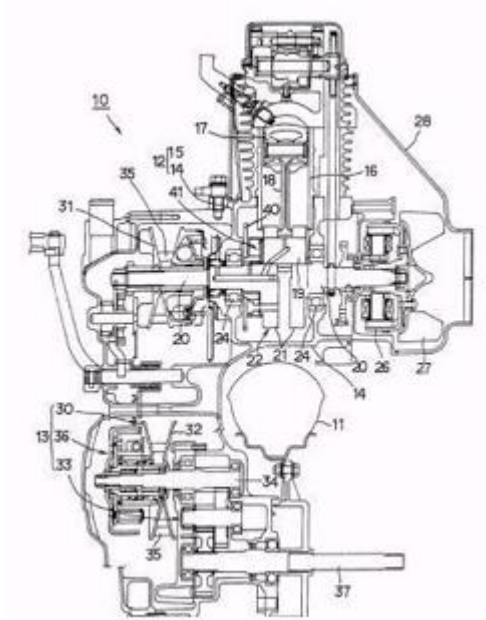

F02B75/007

Replace: The existing Definition statement text and image with the following updated text and image.

Definition statement

This place covers:

Illustrative example of subject matter classified in this place:

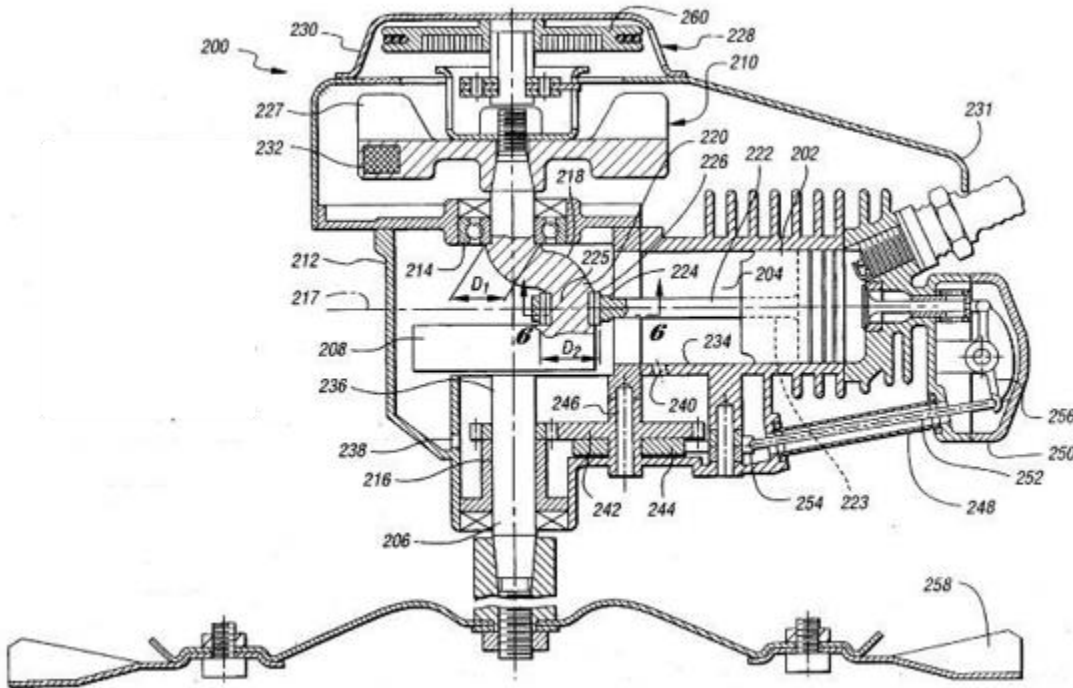

F02B75/04

Delete: The entire Definition statement.

Replace: The existing Informative references table with the following updated table.

References

Informative references

Attention is drawn to the following places, which may be of interest for search:

Connections between crankshaft and piston	F01B9/026
Valve operation	F01L
Controlling engines with variable distances between piston and cylinder head	F02D15/00

DATE: MAY 1, 2024

PROJECT RP10450

F02B75/041

Replace: The existing Definition statement text and image with the following updated text and image.

Definition statement

This place covers:

Illustrative example of subject matter classified in this place:

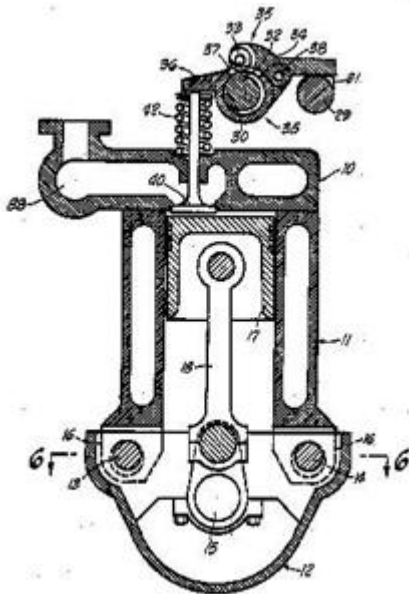

F02B75/044

Replace: The existing Definition statement text and images with the following updated text and images.

Definition statement

This place covers:

Engines characterised by means of an adjustable piston length.

Illustrative examples of subject matter classified in this place:

CPC NOTICE OF CHANGES 1550

DATE: MAY 1, 2024

PROJECT RP10450

1.

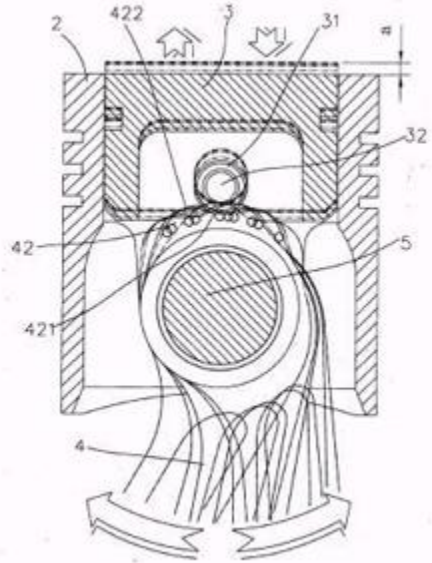

2.

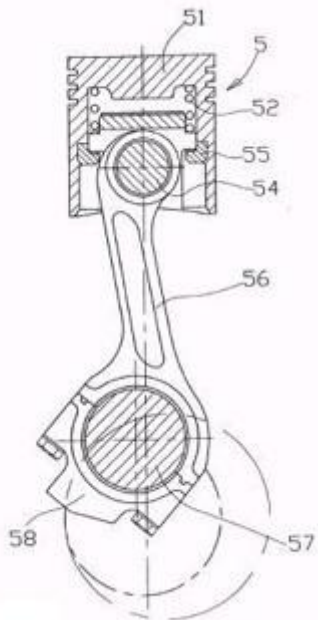

F02B75/047

Replace: The existing Definition statement text and image with the following updated text and image.

Definition statement

This place covers:

Engines characterised by means of variable crankshaft position.

Illustrative example of subject matter classified in this place:

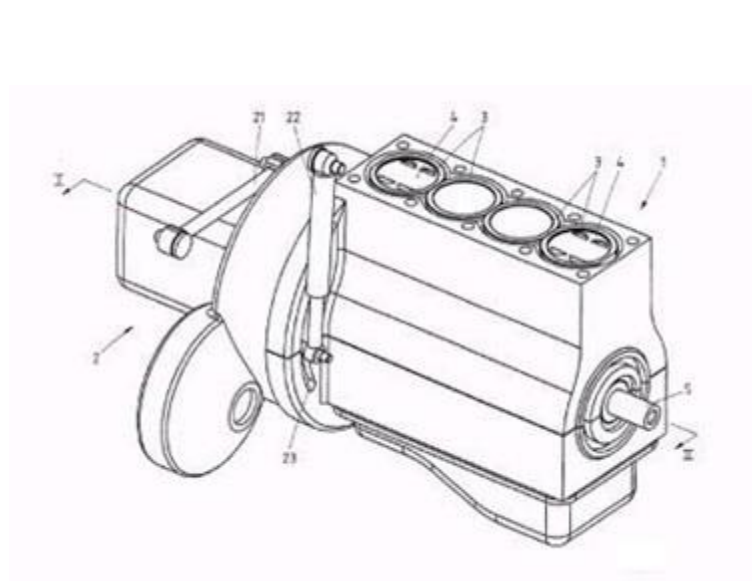

F02B75/065

Replace: The existing Definition statement text and image with the following updated text and image.

Definition statement

This place covers:

Engines with double connecting rods or crankshafts.

Illustrative example of subject matter classified in this place:

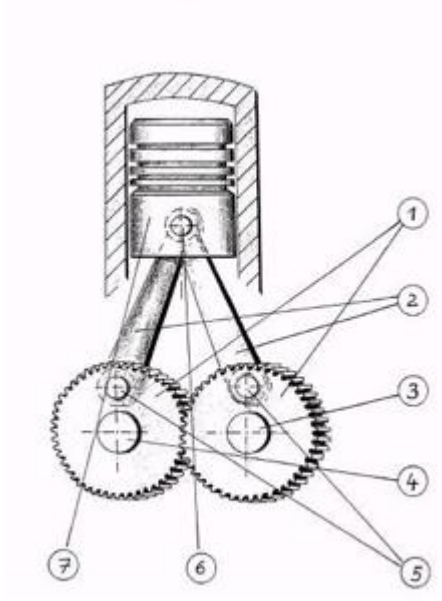

F02B75/08

Replace: The existing Definition statement text and image with the following updated text and image.

Definition statement

This place covers:

Engines with means for preventing corrosion in gas-swept spaces.

Illustrative examples of subject matter classified in this place:

DATE: MAY 1, 2024

PROJECT RP10450

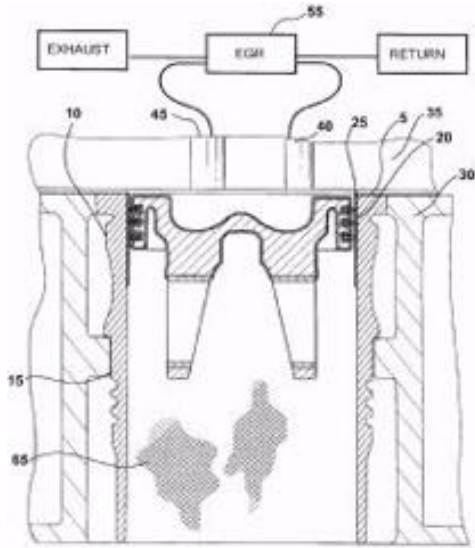

Replace: The existing Informative references table with the following updated table.

References

Informative references

Attention is drawn to the following places, which may be of interest for search:

Cleaning of, preventing corrosion or erosion in, or preventing unwanted deposits in, combustion engines	F02B77/04
Running faces of engine cylinders; Cylinder liners	F16J10/04

F02B75/1896

Replace: The existing Definition statement text and image with the following updated text and image.

Definition statement

This place covers:

Engines with two or more pistons connected to one crank and having a common combustion space.

Illustrative example of subject matter classified in this place:

DATE: MAY 1, 2024

PROJECT RP10450

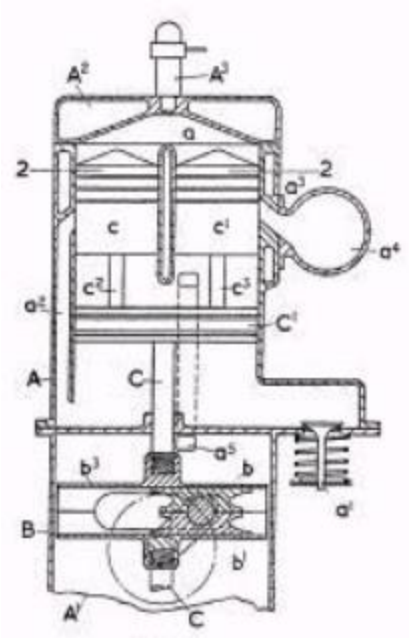

F02B75/20

Replace: The existing Definition statement text and image with the following updated text and image.

Definition statement

This place covers:

Illustrative example of subject matter classified in this place:

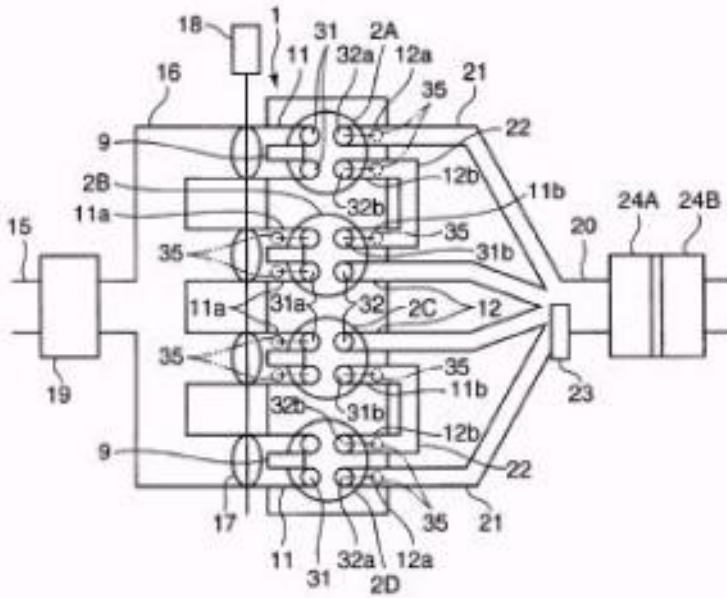

F02B75/22

Replace: The existing Definition statement text and image with the following updated text and image.

Definition statement

This place covers:

Engines with cylinders in V, fan or star arrangement.

Illustrative example of subject matter classified in this place:

DATE: MAY 1, 2024

PROJECT RP10450

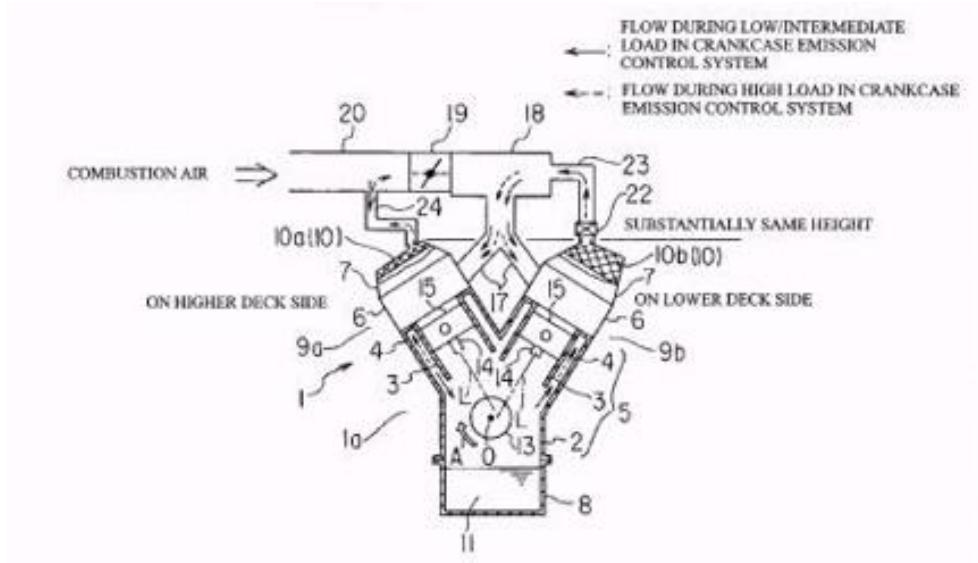

F02B75/221

Replace: The existing Definition statement text and image with the following updated text and image.

Definition statement

This place covers:

Engines with cylinder banks in narrow V-arrangement, having a single cylinder head.

Illustrative example of subject matter classified in this place:

DATE: MAY 1, 2024

PROJECT RP10450

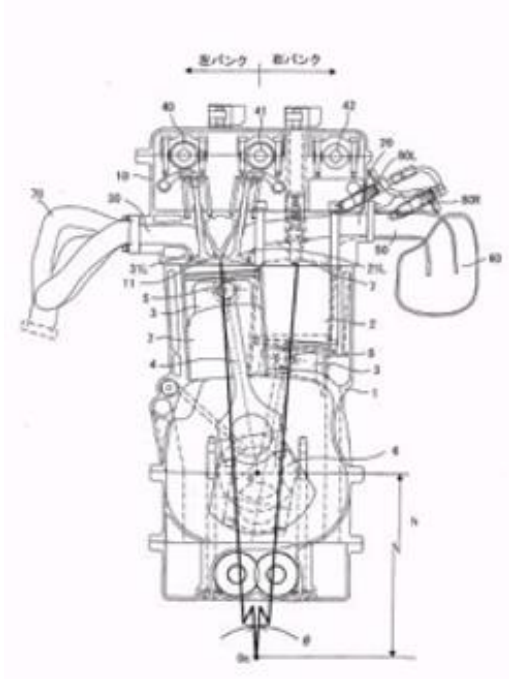

F02B75/222

Replace: The existing Definition statement text and image with the following updated text and image.

Definition statement

This place covers:

Engines with cylinders in star arrangement.

Illustrative example of subject matter classified in this place:

DATE: MAY 1, 2024

PROJECT RP10450

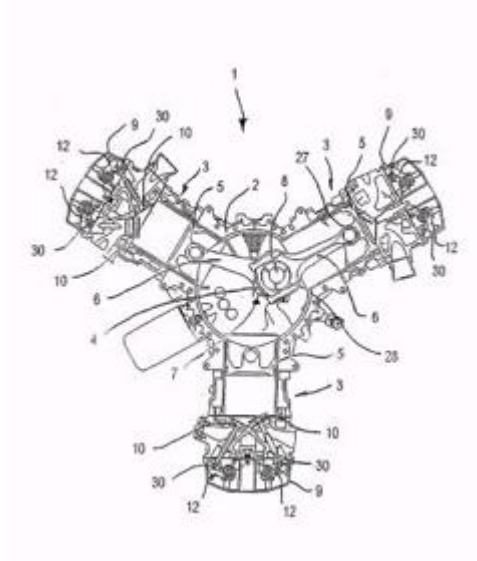

F02B75/224

Replace: The existing Definition statement text and image with the following updated text and image.

Definition statement

This place covers:

Engines with cylinders in fan arrangement.

Illustrative example of subject matter classified in this place:

W9 – 40 Degree Cylinder Bank Sample Configuration View

DATE: MAY 1, 2024

PROJECT RP10450

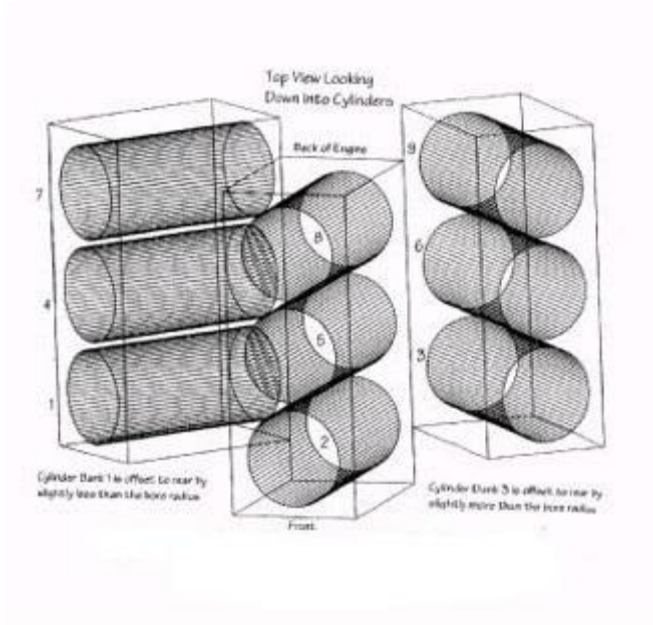

F02B75/225

Replace: The existing Definition statement text and image with the following updated text and image.

Definition statement

This place covers:

Engines having two or more crankshafts.

Illustrative example of subject matter classified in this place:

DATE: MAY 1, 2024

PROJECT RP10450

1a.

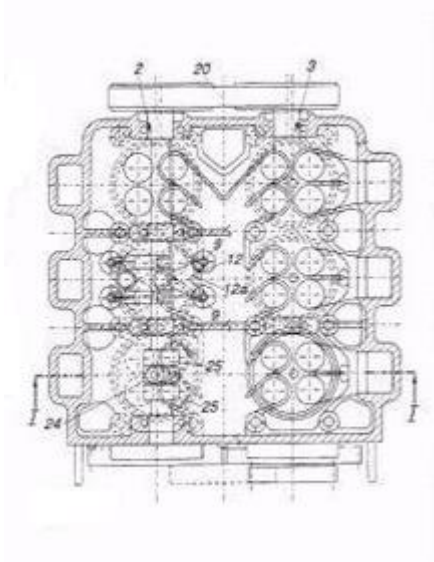

1b.

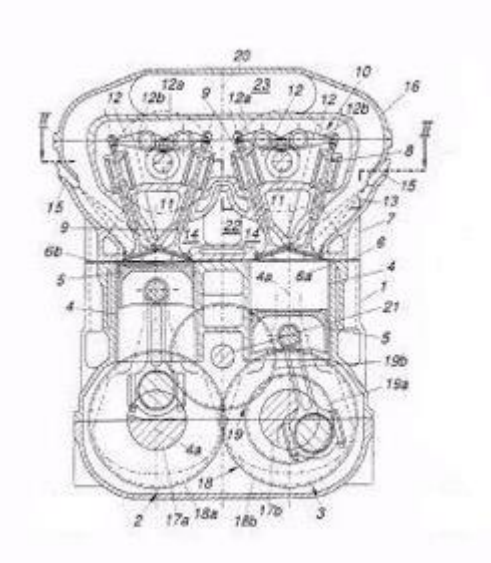

F02B75/227

Replace: The existing Definition statement text and image with the following updated text and images.

Definition statement

This place covers:

Engines with cylinder banks in X-arrangement, e.g. double-V engines.

Illustrative example of subject matter classified in this place:

1a.

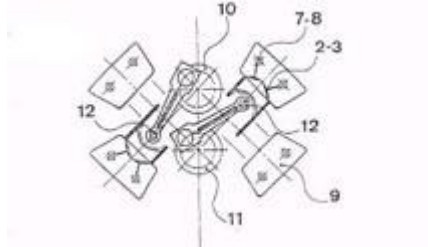

1b.

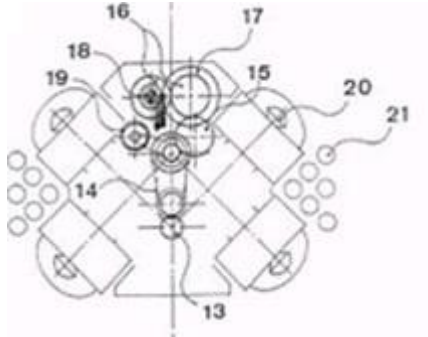

F02B75/228

Replace: The existing Definition statement text and image with the following updated text and image.

Definition statement

This place covers:

Engines with cylinders arranged in parallel banks.

Illustrative example of subject matter classified in this place:

CPC NOTICE OF CHANGES 1550

DATE: MAY 1, 2024

PROJECT RP10450

1a.

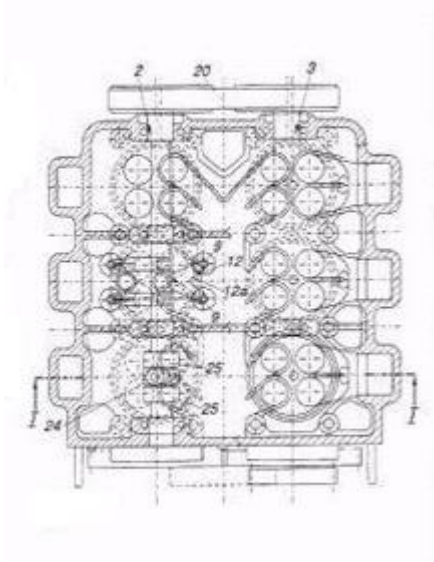

1b.

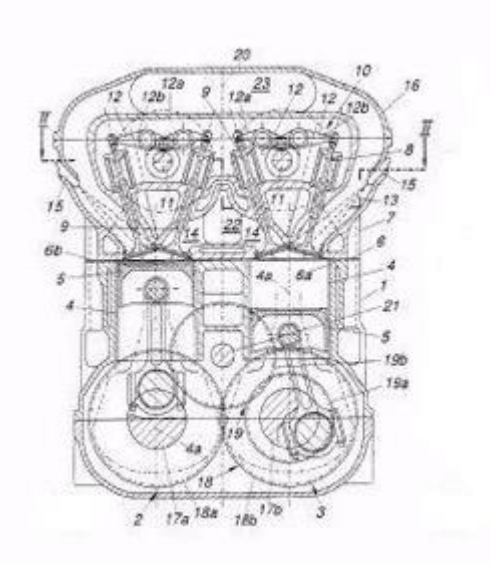

F02B75/243

Replace: The existing Definition statement text and image with the following updated text and image.

DATE: MAY 1, 2024

PROJECT RP10450

Definition statement

This place covers:

Engines with only one crankshaft of the "boxer" type, e.g. all connecting rods attached to separate crankshaft bearings.

Illustrative example of subject matter classified in this place:

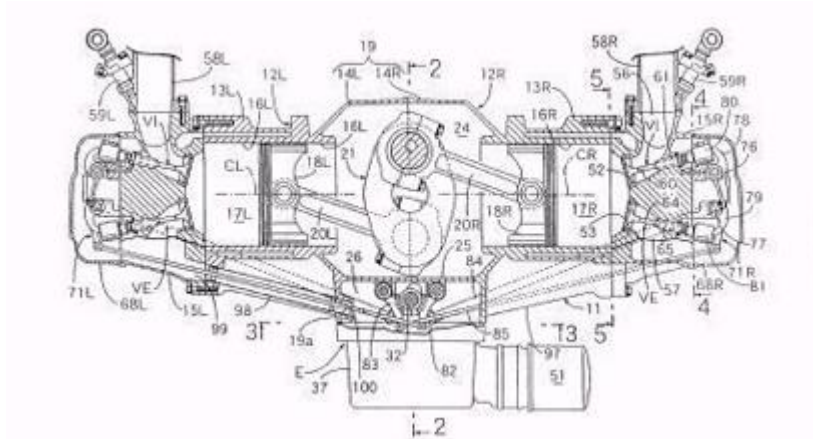

F02B75/246

Replace: The existing Definition statement text and image with the following updated text and image.

Definition statement

This place covers:

Engines with only one crankshaft of the "pancake" type, e.g. pairs of connecting rods attached to common crankshaft bearing.

Illustrative example of subject matter classified in this place:

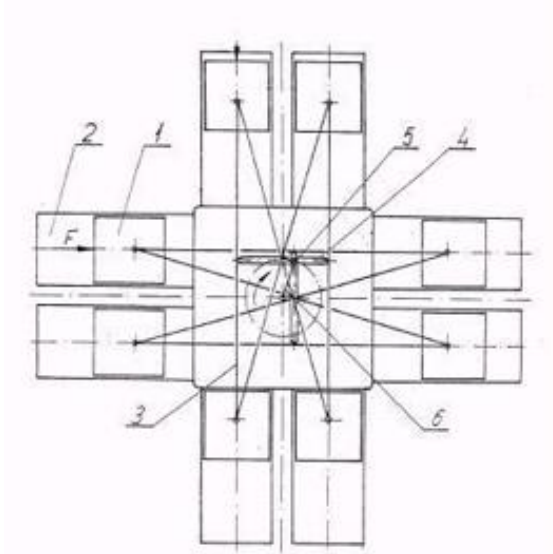

F02B75/26

Replace: The existing Definition statement text and image with the following updated text and image.

Definition statement

This place covers:

Engines with cylinder axes coaxial with, or parallel or inclined to, main-shaft axis;
Engines with cylinder axes arranged substantially tangentially to a circle centred on main-shaft axis.

Illustrative example of subject matter classified in this place:

DATE: MAY 1, 2024

PROJECT RP10450

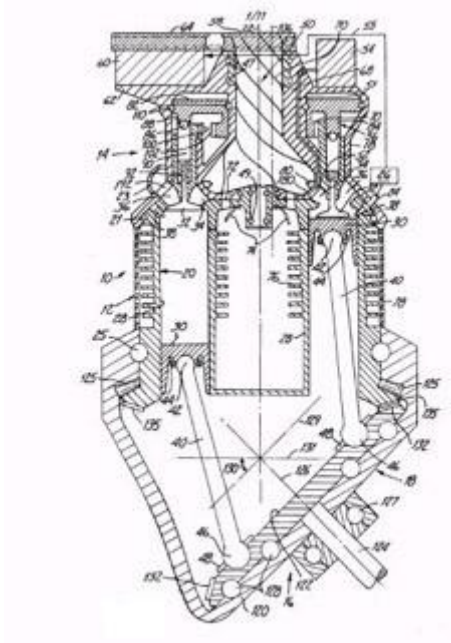

F02B75/265

Replace: The existing Definition statement text and image with the following updated text and image.

Definition statement

This place covers:

Engines with cylinder axes substantially tangentially to a circle centred on main-shaft axis.

Illustrative example of subject matter classified in this place:

DATE: MAY 1, 2024

PROJECT RP10450

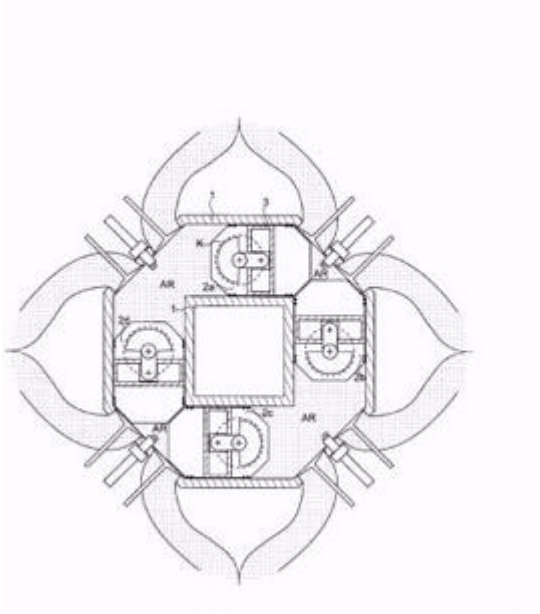

F02B75/28

Replace: The existing Definition statement text and image with the following updated text and image.

Definition statement

This place covers:

Engines with two or more pistons reciprocating within same cylinder or within essentially coaxial cylinders.

Illustrative example of subject matter classified in this place:

DATE: MAY 1, 2024

PROJECT RP10450

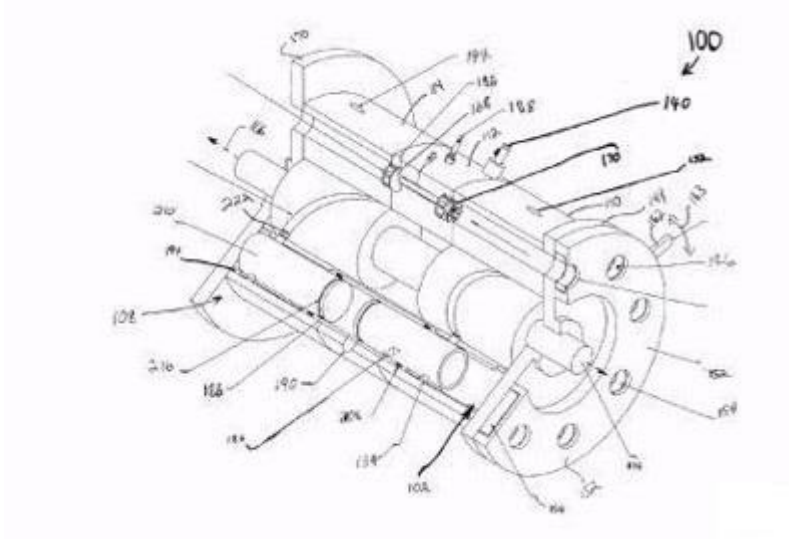

References

Replace: The existing Informative references table with the following updated table.

Informative references

Attention is drawn to the following places, which may be of interest for search:

Engines with oppositely reciprocating pistons	F01B7/02
---	--------------------------

F02B75/282

Replace: The existing Definition statement text and image with the following updated text and image.

Definition statement

This place covers:

Engines with pistons having equal strokes.

Illustrative example of subject matter classified in this place:

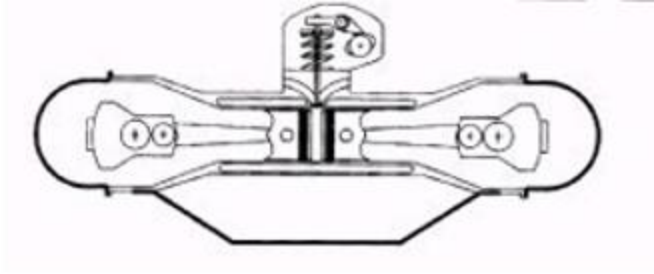

F02B75/285

Replace: The existing Definition statement text and image with the following updated text and images.

Definition statement

This place covers:

Engines comprising a free auxiliary piston.

Illustrative example of subject matter classified in this place:

1a.

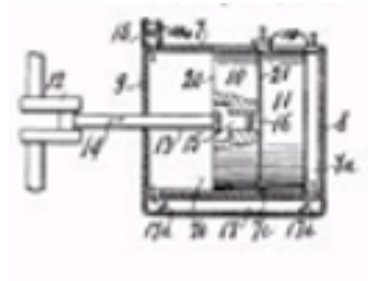

1b.

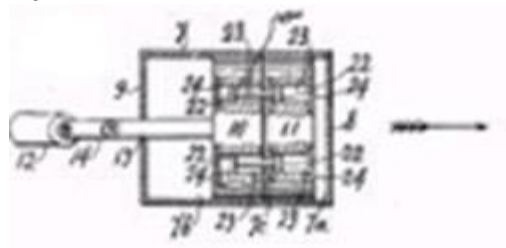

DATE: MAY 1, 2024

PROJECT RP10450

1c.

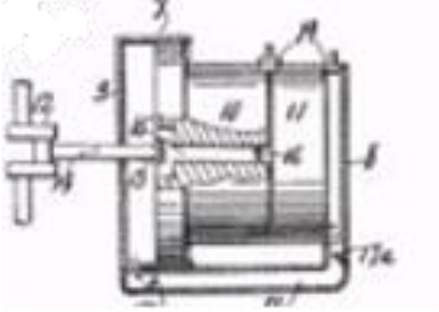

F02B75/287

Replace: The existing Definition statement with the following updated statement.

Definition statement

This place covers:

Engines with several pistons positioned in one cylinder one behind the other.

Illustrative examples of subject matter classified in this place:

1.

CPC NOTICE OF CHANGES 1550

DATE: MAY 1, 2024

PROJECT RP10450

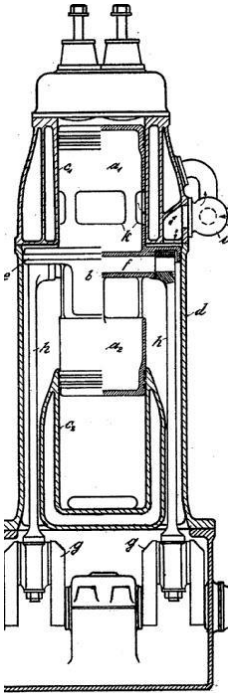

2.

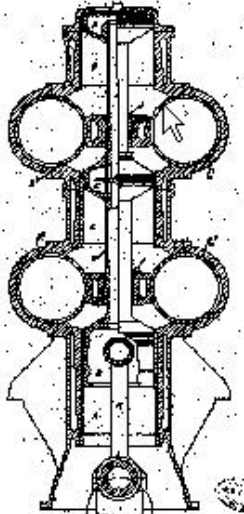

F02B75/30

Replace: The existing Definition statement text and image with the following updated text and image.

Definition statement

This place covers:

Engines with one working piston sliding inside another.

Illustrative example of subject matter classified in this place:

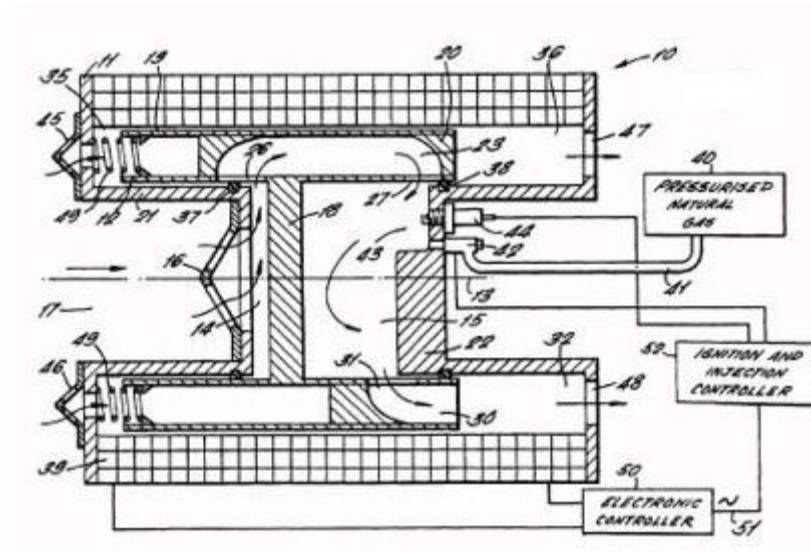

F02B75/32

Replace: The existing Definition statement with the following updated statement.

Definition statement

This place covers:

This subgroup contains all mechanisms between pistons and main shafts not otherwise described in more pertinent classes.

Illustrative example of subject matter classified in this place:

DATE: MAY 1, 2024

PROJECT RP10450

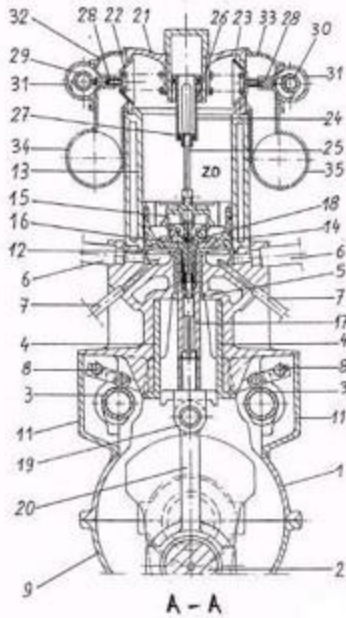

Engine with pulled con-rods during working stroke.

F02B75/34

Replace: The existing Definition statement with the following updated statement.

Definition statement

This place covers:

Ultra-small engines, e.g. for driving models. Any small engine such as miniature CO₂ engines, compressed air engines. Small engines having different cycles: diesel, using glow ignition, spark ignition.

Illustrative example of subject matter classified in this place:

DATE: MAY 1, 2024

PROJECT RP10450

1a.

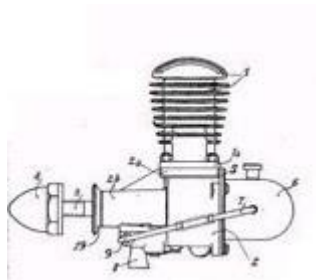

1b.

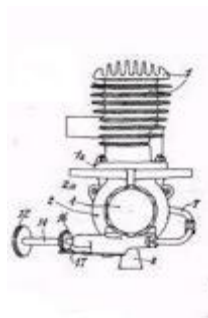

1c.

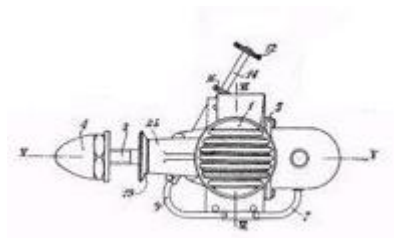

Delete: The entire Synonyms and Keywords section.

Insert: The following new Glossary of terms section.

Glossary of terms

In this place, the following acronyms, terms or expressions are used with the meaning indicated:

CPC NOTICE OF CHANGES 1550

DATE: MAY 1, 2024

PROJECT RP10450

model diesel engine	compression ignition engine, e.g. 2-stroke homogeneous charge compression ignition engines of the variable compression type
nitro fuel	nitromethane, used as a fuel or fuel additive for model glow plug engines
model glow plug engine	positive ignition engines comprising a glow plug comprising a wire, e.g. from platinum, heated by ohmic resistance at starting and continues to glow during operation due to combustion heat and/or catalytic reactions
castor oil	vegetable oil from the castor beans used as lubricant for model engine fuel
amyl nitrate	fuel additive for model diesel engines

F02B75/36

Replace: The existing Definition statement text and image with the following updated text and image.

Definition statement

This place covers:

Engines with parts of combustion- or working-chamber walls resiliently yielding under pressure.

Illustrative example of subject matter classified in this place:

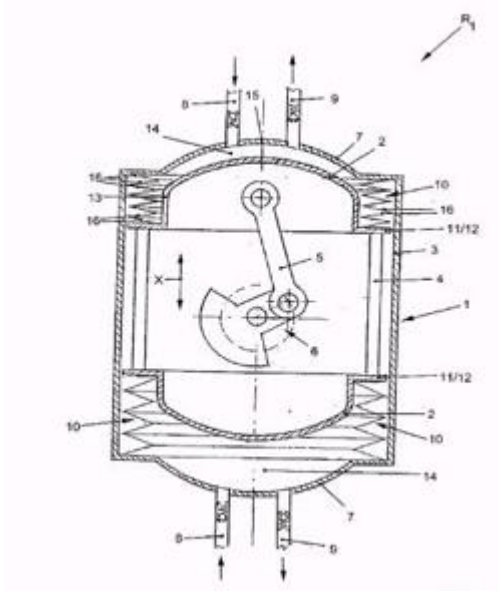

F02B75/38

Replace: The existing Definition statement text and image with the following updated text and image.

Definition statement

This place covers:

Reciprocating piston engines.

Illustrative example of subject matter classified in this place:

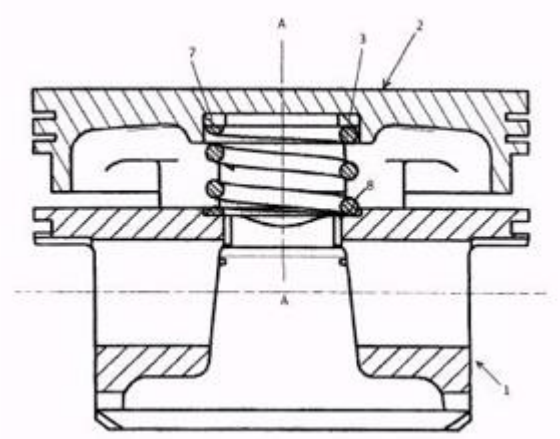

F02B75/40

Replace: The existing Definition statement with the following updated statement.

Definition statement

This place covers:

Other reciprocating-piston engines.

F02B77/04

Replace: The existing Definition statement text and image with the following updated text and image.

Definition statement

This place covers:

Any cleaning of engines, decarbonising, de-coking.

Illustrative example of subject matter classified in this place:

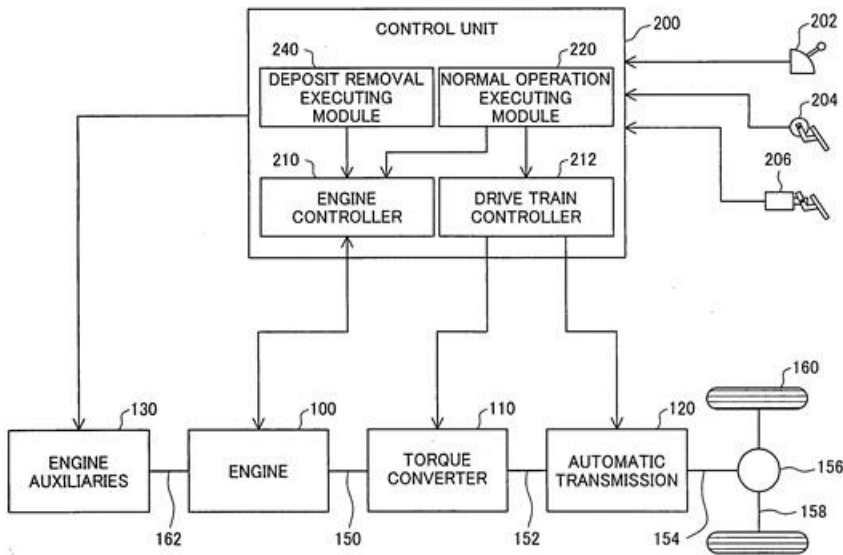

References

Delete: The entire Limiting references section.

Insert: The following new Informative references section.

Informative references

Attention is drawn to the following places, which may be of interest for search:

Cleaning of fuel injection apparatus	F02M65/00
--------------------------------------	---------------------------

F02B77/08

References

Insert: The following new Limiting references section.

Limiting references

This place does not cover:

Thermal insulation	F02B 77/11
Monitoring or diagnostic devices for exhaust-gas treatment apparatus	F01N 11/00

Delete: The following reference from the Informative references table.

Informative references

Attention is drawn to the following places, which may be of interest for search:

Thermal insulation	F02B77/11
--------------------	---------------------------

F02B77/081

Replace: The existing Definition statement with the following updated statement.

Definition statement

This place covers:

Safety, indicating or supervising devices relating to endless members.

Illustrative example of subject matter classified in this place:

1a.

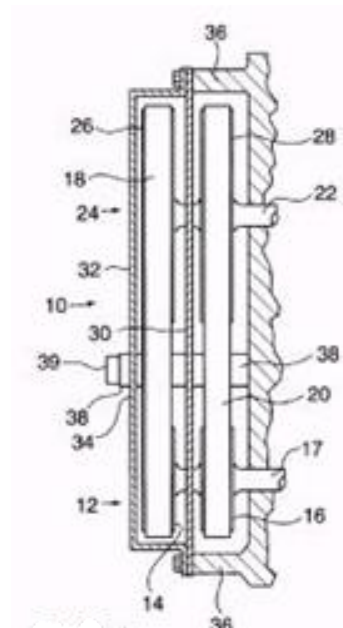

DATE: MAY 1, 2024

PROJECT RP10450

1b.

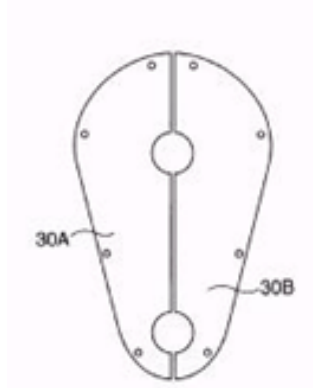

1c.

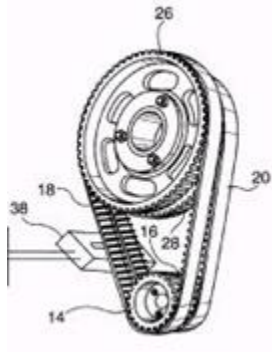

References

Replace: The existing symbol in the reference with the following updated symbol.

Informative references

Attention is drawn to the following places, which may be of interest for search:

Endless members, e.g. belts, for driving auxiliary apparatus	F02B67/06
--	---------------------------

[F02B77/082](#)

Replace: The existing Definition statement text and image with the following updated text and image.

Definition statement

This place covers:

Safety, indicating or supervising devices relating to valves.

Illustrative example of subject matter classified in this place:

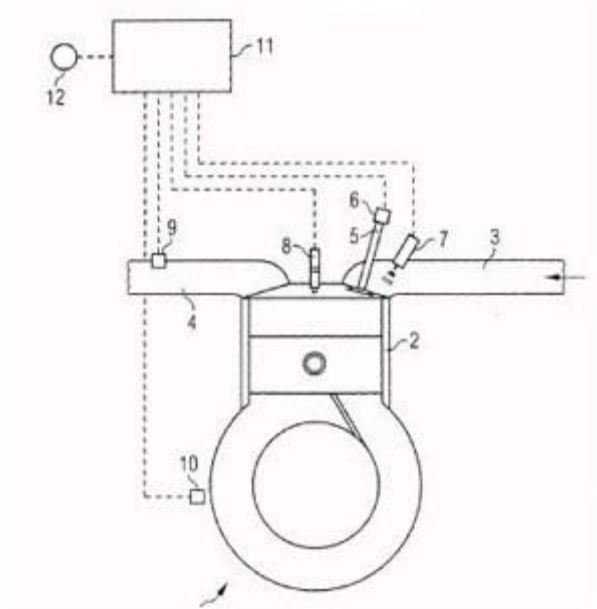

Insert: The following new Informative references section.

References

Informative references

Attention is drawn to the following places, which may be of interest for search:

Controlling engines by air induction conduits	F02D9/02
Throttle position sensors for pivoting throttle valves	F02D9/105
Controlling engine output by varying inlet or exhaust valve operation	F02D13/00
Electrical control of intake air	F02D41/0002
Gas sensors in intake manifold for closed loop engine control	F02D41/144
Sensors or measuring devices for combustion-air cleaners	F02M35/0205
Air intakes comprising sensors	F02M35/10373
Indicating or alarms for valves in general	F16K37/00

F02B77/083

Replace: The existing Definition statement text and image with the following updated text and image.

Definition statement

This place covers:

Safety, indicating or supervising devices relating to maintenance, e.g. diagnostic device.

Illustrative example of subject matter classified in this place:

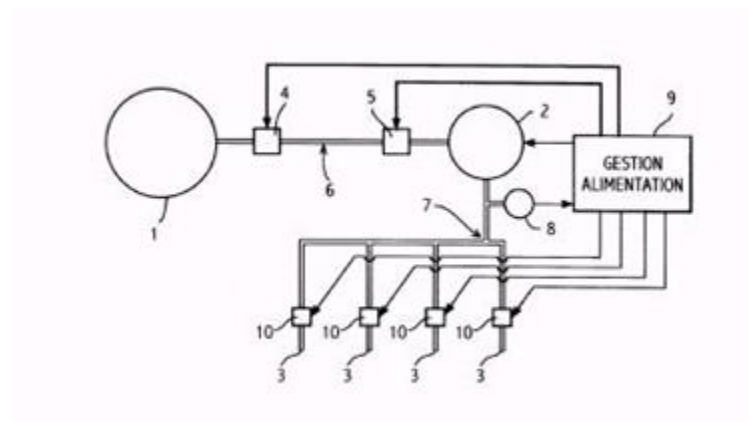

References

Insert: The following new Limiting references section.

Limiting references

This place does not cover:

Indicating and safety devices concerning lubricant level	F01M11/10
--	---------------------------

Replace: The existing Informative references table with the following updated table.

Informative references

Attention is drawn to the following places, which may be of interest for search:

Sensors or measuring devices for air cleaners	F02M35/0205
---	-------------

F02B77/084

Replace: The existing Definition statement text and image with the following updated text and image.

Definition statement

This place covers:

Safety, indicating or supervising devices indicating economy.

Illustrative example of subject matter classified in this place:

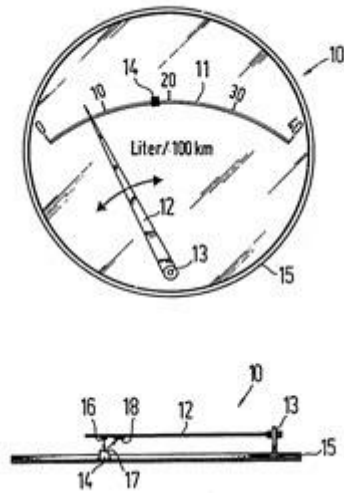

F02B77/085

Replace: The existing Definition statement text and image with the following updated text and image.

Definition statement

This place covers:

Safety, indicating or supervising devices with sensors measuring combustion processes, e.g. knocking, pressure, ionization, combustion flame.

Illustrative example of subject matter classified in this place:

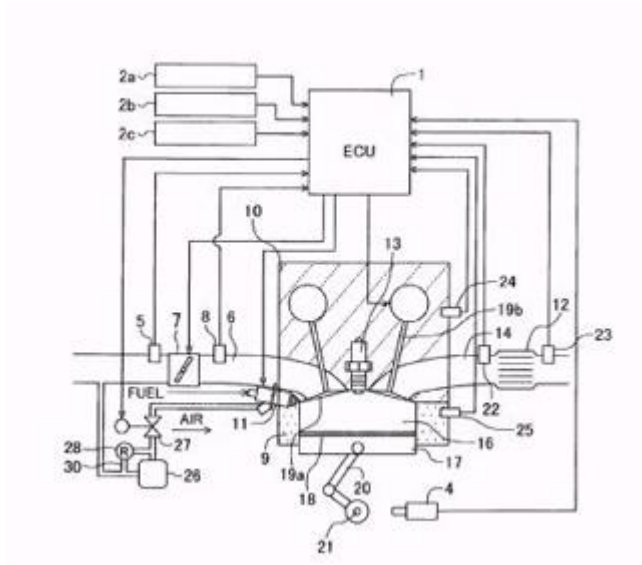

References

Insert: The following new reference in the Informative references table.

Informative references

Attention is drawn to the following places, which may be of interest for search:

Sensors for intake systems	F02M35/10373
----------------------------	------------------------------

F02B77/086

Replace: The existing Definition statement with the following updated statement.

Definition statement

This place covers:

Sensor arrangements in the exhaust, e.g. for temperature, misfire, air/fuel ratio, oxygen sensors.

Illustrative examples of subject matter classified in this place:

CPC NOTICE OF CHANGES 1550

DATE: MAY 1, 2024

PROJECT RP10450

1.

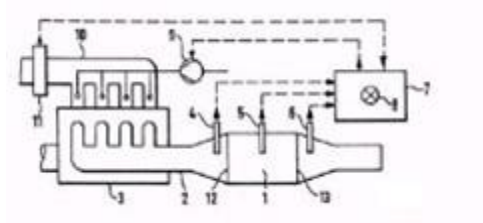

2.

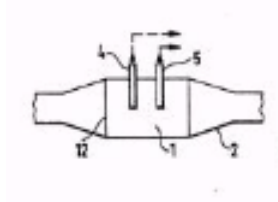

3.

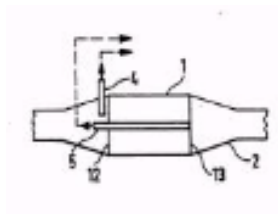

F02B77/088

Delete: The image from the Definition statement, so that the new statement appears as follows.

Definition statement

This place covers:

Safety, indicating or supervising devices relating to tightness.

DATE: MAY 1, 2024

PROJECT RP10450

F02B77/089

Insert: The following new Limiting references section.

References

Limiting references

This place does not cover:

Indicating and safety devices concerning coolant temperature	F01P11/16
--	---------------------------

Delete: The entire Informative references section.

F02B77/10

Replace: The existing Definition statement with the following updated statement.

Definition statement

This place covers:

Safety means relating to crankcase explosions, e.g. explosion relief valves or shrapnel containment arrangements.

Illustrative example of subject matter classified in this place:

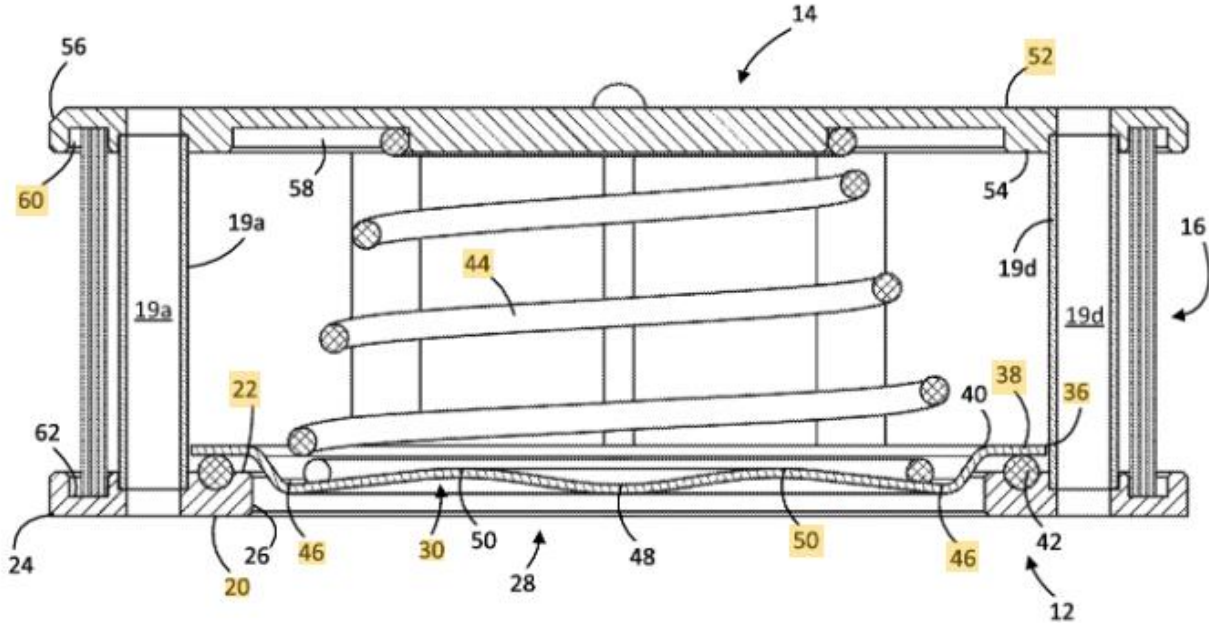

Insert: The following new Informative references section.

References

Informative references

Attention is drawn to the following places, which may be of interest for search:

Air intakes with means to avoid a change in direction of incoming fluid or flame arrestors for backfire prevention	F02M35/10275
--	------------------------------

F02B77/14

Replace: The existing Definition statement with the following updated statement.

Definition statement

This place covers:

Engine-driven auxiliary devices combined into units, e.g. a water pump and an alternator combined in one unit.

CPC NOTICE OF CHANGES 1550

DATE: MAY 1, 2024

PROJECT RP10450

Illustrative examples of subject matter classified in this place:

1.

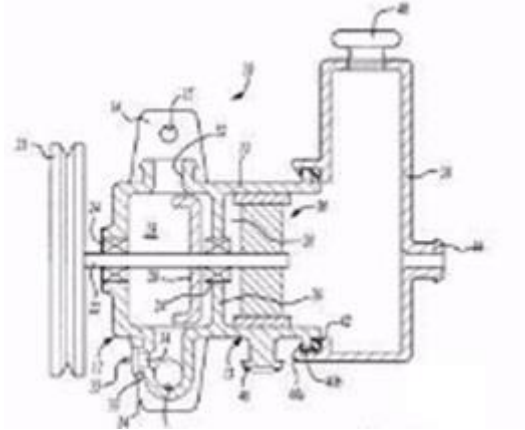

2.

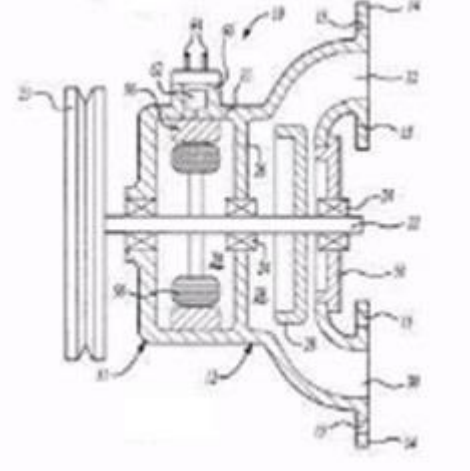

CPC NOTICE OF CHANGES 1550

DATE: MAY 1, 2024

PROJECT RP10450

3. REVISION CONCORDANCE LIST (RCL)

Type*	From CPC Symbol (existing)	To CPC Symbol(s)
D	F02B 2031/003	< administrative transfer to F02B 31/08 INV>
F	F02B 2031/006	F02B 31/085, F02B 31/087
C	F02B 31/02	F02B 31/02, F02B31/042, F02B 31/08, F02B 31/085, F02B 31/087
C	F02B 31/04	F02B 31/04, F02B 31/042
F	F02B 31/082	F02B 31/08, F02B 31/042

* C = entries with modified file scope where reclassification of documents from the entries is involved; Q = new entries which are firstly populated with documents via administrative transfers from deleted (D) entries. Afterwards, the transferred documents into the Q entry will either stay or be moved to more appropriate entries, as determined by intellectual reclassification; D = deleted entries; F = frozen entries will be deleted once reclassification of documents from the entries is completed.

NOTES:

- Only C, D, F, and Q type entries are included in the table above.
- When multiple symbols are included in the “To” column, do not use ranges of symbols.
- For administrative transfer of documents, the following text should be used: “< administrative transfer to XX>”, “<administrative transfer to XX and YY simultaneously>”, or “<administrative transfer to XX, YY, ...and ZZ simultaneously>” when administrative transfer of the same documents is to more than one place.
- Administrative transfer to main trunk groups is assumed to be the source allocation type, unless otherwise indicated.
- Administrative transfer to 2000/Y series groups is assumed to be “additional information”.
- If needed, instructions for allocation type should be indicated within the angle brackets using the abbreviations “ADD” or “INV”: <administrative transfer to XX ADD>, <administrative transfer to XX INV>, or < administrative transfer to XX ADD, YY INV, ... and ZZ ADD simultaneously>.
- In certain situations, the “D” entries of 2000-series or Y-series groups may not require a destination (“To”) symbol, however it is required to specify “<no transfer>” in the “To” column for such cases.
- RCL is not needed for finalisation projects.

CPC NOTICE OF CHANGES 1550

DATE: MAY 1, 2024

PROJECT RP10450

4. CHANGES TO THE CPC-TO-IPC CONCORDANCE LIST (CICL)

<u>CPC</u>	<u>IPC</u>	<u>Action*</u>
F02B 2031/003		DELETE
F02B 31/042	F02B 31/04	NEW

* Action column:

- For an (N) or (Q) entry, provide an IPC symbol and complete the Action column with “NEW.”
- For an existing CPC main trunk entry or indexing entry where the existing IPC symbol needs to be changed, provide an updated IPC symbol and complete the Action column with “UPDATED.”
- For a (D) CPC entry or indexing entry complete the Action column with “DELETE.” IPC symbol does not need to be included in the IPC column.
- For an (N) 2000 series CPC entry which is positioned within the main trunk scheme (breakdown code) provide an IPC symbol and complete the action column with “NEW”.
- For an (N) 2000 series CPC entry positioned at the end of the CPC scheme (orthogonal code), with no IPC equivalent, complete the IPC column with “CPCONLY” and complete the action column with “NEW”.

NOTES:

- F symbols are not included in the CICL table above.
- T and M symbols are not included in the CICL table above unless a change to the existing IPC is desired.