

EUROPEAN PATENT OFFICE  
U.S. PATENT AND TRADEMARK OFFICE

CPC NOTICE OF CHANGES 1070

DATE: MAY 1, 2021

PROJECT RP0676

**The following classification changes will be effected by this Notice of Changes:**

<u>Action</u>	<u>Subclass</u>	<u>Group(s)</u>
<b>SCHEME:</b>		
Symbols New:	B29C	70/003, 70/0035, 70/302, 70/304, 70/461, 70/544, 70/549
	B29D	99/0005
Titles Changed:	B29C	2043/3644, 2043/3655
	B29C	70/30, 70/54
Warnings New:	B29C	70/00, 70/003, 70/0035, 70/30, 70/302, 70/304, 70/46, 70/461, 70/54, 70/544, 70/549
	B29D	99/0003, 99/0005
<b>DEFINITIONS:</b>		
Definitions Modified:	B29C	70/00, 70/30, 70/54

**No other subclasses/groups are impacted by this Notice of Changes.**

CPC NOTICE OF CHANGES 1070

DATE: MAY 1, 2021

PROJECT RP0676

**This Notice of Changes includes the following [Check the ones included]:**

1. CLASSIFICATION SCHEME CHANGES

- A. New, Modified or Deleted Group(s)
- B. New, Modified or Deleted Warning(s)
- C. New, Modified or Deleted Note(s)
- D. New, Modified or Deleted Guidance Heading(s)

2. DEFINITIONS

- A. New or Modified Definitions (Full definition template)
- B. Modified or Deleted Definitions (Definitions Quick Fix)

3.  REVISION CONCORDANCE LIST (RCL)

4.  CHANGES TO THE CPC-TO-IPC CONCORDANCE LIST (CICL)

5.  CHANGES TO THE CROSS-REFERENCE LIST (CRL)

CPC NOTICE OF CHANGES 1070

DATE: MAY 1, 2021

PROJECT RP0676

1. CLASSIFICATION SCHEME CHANGES

A. New, Modified or Deleted Group(s)

**SUBCLASS B29C - SHAPING OR JOINING OF PLASTICS; SHAPING OF MATERIAL IN A PLASTIC STATE, NOT OTHERWISE PROVIDED FOR; AFTER-TREATMENT OF THE SHAPED PRODUCTS, e.g. REPAIRING** (making preforms B29B 11/00; making laminated products by combining previously unconnected layers which become one product whose layers will remain together B32B 37/00 - B32B 41/00)

<u>Type*</u>	<u>Symbol</u>	<u>Indent Level Number of dots (e.g. 0, 1, 2)</u>	<u>Title</u> <u>“CPC only” text should normally be enclosed in {curly brackets}**</u>	<u>Transferred to<sup>#</sup></u>
M	B29C2043/3644	4	{Vacuum bags; Details thereof, e.g. fixing or clamping (B29C70/544 takes precedence; applying pressure through membranes B29C51/28; bladders for making tires B29D30/0601; flexible pressing means B30B5/02; membrane press B30B9/22; vacuum laminating B32B37/1018)}	
M	B29C2043/3655	4	{Pressure transmitters, e.g. caul plates; Pressure pads (B29C 70/549 takes precedence)}	
C	B29C70/00	0	Shaping composites, i.e. plastics material comprising reinforcements, fillers or preformed parts, e.g. inserts	B29C70/00, B29C70/003, B29C70/0035
N	B29C70/003	1	{characterised by the matrix material, e.g. material composition or physical properties}	
N	B29C70/0035	2	{comprising two or more matrix materials}	
C	B29C70/30	3	Shaping by lay-up, i.e. applying fibres, tape or broadsheet on a mould, former or core; Shaping by spray-up, i.e. spraying of fibres on a mould, former or core	B29C70/30, B29C70/302, B29C70/304
N	B29C70/302	4	{Details of the edges of fibre composites, e.g. edge finishing or means to avoid delamination}	
N	B29C70/304	4	{In-plane lamination by juxtaposing or interleaving of plies, e.g. scarf joining}	
C	B29C70/46	5	using matched moulds, e.g. for deforming sheet moulding compounds [SMC] or prepregs	B29C70/46, B29C70/461
N	B29C70/461	6	{Rigid movable compressing mould parts acting independently from opening or closing action of the main mould}	

## CPC NOTICE OF CHANGES 1070

DATE: MAY 1, 2021

PROJECT RP0676

<u>Type*</u>	<u>Symbol</u>	<u>Indent Level Number of dots (e.g. 0, 1, 2)</u>	<u>Title</u> <u>“CPC only” text should normally be enclosed in {curly brackets}**</u>	<u>Transferred to#</u>
C	B29C70/54	3	Component parts, details or accessories; Auxiliary operations{, e.g. feeding or storage of prepregs or SMC after impregnation or during ageing }	B29C70/54, B29C70/544, B29C70/549
U	B29C70/543	4	{Fixing the position or configuration of fibrous reinforcements before or during moulding (for non-woven fabrics D04H3/08)}	
N	B29C70/544	4	{Details of vacuum bags, e.g. materials or shape }	
U	B29C70/548	5	{using distribution constructions, e.g. channels incorporated in or associated with the mould }	
N	B29C70/549	4	{Details of caul plates, e.g. materials or shape }	

**SUBCLASS B29D - PRODUCING PARTICULAR ARTICLES FROM PLASTICS OR FROM SUBSTANCES IN A PLASTIC STATE** (making granules B29B 9/00; making preforms B29B 11/00)

<u>Type*</u>	<u>Symbol</u>	<u>Indent Level Number of dots (e.g. 0, 1, 2)</u>	<u>Title</u> <u>“CPC only” text should normally be enclosed in {curly brackets}**</u>	<u>Transferred to#</u>
C	B29D99/0003	1	{Producing profiled members, e.g. beams }	B29D99/0003, B29D99/0005
N	B29D99/0005	2	{Producing noodles, i.e. composite gap fillers, characterised by their construction }	

\*N = new entries where reclassification into entries is involved; C = entries with modified file scope where reclassification of documents from the entries is involved; Q = new entries which are firstly populated with documents via administrative transfers from deleted (D) entries. Afterwards, the transferred documents into the Q entry will either stay or be moved to more appropriate entries, as determined by intellectual reclassification; T= existing entries with enlarged file scope, which receive documents from C or D entries, e.g. when a limiting reference is removed from the entry title; M = entries with no change to the file scope (no reclassification); D = deleted entries; F = frozen entries will be deleted once reclassification of documents from the entries is completed; U = entries that are unchanged.

## NOTES:

- \*\*No {curly brackets} are used for titles in CPC only subclasses, e.g. C12Y, A23Y; 2000 series symbol titles of groups found at the end of schemes (orthogonal codes); or the Y section titles. The {curly brackets} are used for 2000 series symbol titles found interspersed throughout the main trunk schemes (breakdown codes).
- U groups: it is obligatory to display the required “anchor” symbol (U group), i.e. the entry immediately preceding a new group or an array of new groups to be created (in case new groups are not clearly subgroups of C-type groups). Always include the symbol, indent level and title of the U group in the table above.
- All entry types should be included in the scheme changes table above for better understanding of the overall scheme change picture. Symbol, indent level, and title are required for all types .

## CPC NOTICE OF CHANGES 1070

DATE: MAY 1, 2021

### PROJECT RP0676

- “Transferred to” column must be completed for all C, D, F, and Q type entries. F groups will be deleted once reclassification is completed.
- When multiple symbols are included in the “Transferred to” column, avoid using ranges of symbols in order to be as precise as possible.
- For administrative transfer of documents, the following text should be used: “< administrative transfer to XX>”, “<administrative transfer to XX and YY simultaneously>”, or “<administrative transfer to XX, YY, ...and ZZ simultaneously>” when administrative transfer of the same documents is to more than one place.
- Administrative transfer to main trunk groups is assumed to be the source allocation type, unless otherwise indicated.
- Administrative transfer to 2000/Y series groups is assumed to be “additional information”.
- If needed, instructions for allocation type should be indicated within the angle brackets using the abbreviations “ADD” or “INV”: <administrative transfer to XX ADD> , <administrative transfer to XX INV>, or < administrative transfer to XX ADD, YY INV, ... and ZZ ADD simultaneously>.
- In certain situations, the “D” entries of 2000-series or Y-series groups may not require a destination (“Transferred to”) symbol, however it is required to specify “<no transfer>” in the “Transferred to” column for such cases.
- For finalisation projects, the deleted “F” symbols should have <no transfer> in the “Transferred to” column.
- For more details about the types of scheme change, see CPC Guide.

CPC NOTICE OF CHANGES 1070

DATE: MAY 1, 2021

PROJECT RP0676

B. New, Modified or Deleted Warning(s)

**SUBCLASS B29C - SHAPING OR JOINING OF PLASTICS; SHAPING OF MATERIAL IN A PLASTIC STATE, NOT OTHERWISE PROVIDED FOR; AFTER-TREATMENT OF THE SHAPED PRODUCTS, e.g. REPAIRING** (making preforms B29B 11/00; making laminated products by combining previously unconnected layers which become one product whose layers will remain together B32B 37/00 - B32B 41/00)

<u>Type*</u>	<u>Location</u>	<u>Old Warning</u>	<u>New/Modified Warning</u>
N	B29C70/00		Group B29C70/00 is impacted by reclassification into groups B29C70/003 – B29C70/0035. Groups B29C70/00 and B29C70/003 – B29C70/0035 should be considered in order to perform a complete search.
N	B29C70/003		Group B29C70/003 is incomplete pending reclassification of documents from group B29C70/00. Groups B29C70/00 and B29C70/003 should be considered in order to perform a complete search.
N	B29C70/0035		Group B29C70/0035 is incomplete pending reclassification of documents from group B29C70/00. Groups B29C70/00 and B29C70/0035 should be considered in order to perform a complete search.
N	B29C70/30		Group B29C70/30 is impacted by reclassification into groups B29C70/302 – B29C70/304. Groups B29C70/30 and B29C70/302 – B29C70/304 should be considered in order to perform a complete search.
N	B29C70/302		Group B29C70/302 is incomplete pending reclassification of documents from group B29C70/30. Groups B29C70/30 and B29C70/302 should be considered in order to perform a complete search.
N	B29C70/304		Group B29C70/304 is incomplete pending reclassification of documents from group B29C70/30. Groups B29C70/30 and B29C70/304 should be considered in order to perform a complete search.
N	B29C70/46		Group B29C70/46 is impacted by reclassification into group B29C70/461. Groups B29C70/46 and B29C70/461 should be considered in order to perform a complete search.
N	B29C70/461		Group B29C70/461 is incomplete pending reclassification of documents from group B29C70/46. Groups B29C70/46 and B29C70/461 should be considered in order to perform a complete search.

CPC NOTICE OF CHANGES 1070

DATE: MAY 1, 2021

PROJECT RP0676

<u>Type*</u>	<u>Location</u>	<u>Old Warning</u>	<u>New/Modified Warning</u>
N	B29C70/54		Group B29C70/54 is impacted by reclassification into groups B29C70/544 and B29C70/549. Groups B29C70/54, B29C70/544 and B29C70/549 should be considered in order to perform a complete search.
N	B29C70/544		Group B29C70/544 is incomplete pending reclassification of documents from group B29C70/54. Groups B29C70/54 and B29C70/544 should be considered in order to perform a complete search.
N	B29C70/549		Group B29C70/549 is incomplete pending reclassification of documents from group B29C70/54. Groups B29C70/54 and B29C70/549 should be considered in order to perform a complete search.

**SUBCLASS B29D - PRODUCING PARTICULAR ARTICLES FROM PLASTICS OR FROM SUBSTANCES IN A PLASTIC STATE** (making granules B29B 9/00; making preforms B29B 11/00)

<u>Type*</u>	<u>Location</u>	<u>Old Warning</u>	<u>New/Modified Warning</u>
N	B29D99/0003		Group B29D99/0003 is impacted by reclassification into group B29D99/0005. Groups B29D99/0003 and B29D99/0005 should be considered in order to perform a complete search.
N	B29D99/0005		Group B29D99/0005 is incomplete pending reclassification of documents from group B29D99/0003. Groups B29D99/0003 and B29D99/0005 should be considered in order to perform a complete search.

\*N = new warning, M = modified warning, D = deleted warning

NOTE: The "Location" column only requires the symbol PRIOR to the location of the warning. No further directions such as "before" or "after" are required.

DATE: MAY 1, 2021

PROJECT RP0676

**2. A. DEFINITIONS (modified)**Insert: The following modifications in the Definitions.**B29C 70/00****References*****Limiting references***Delete: The entire Limiting references section and all table row.***Informative references***Insert: The following rows into the Informative references table.

Nanotechnology for materials or surface science, e.g. nanocomposites	<a href="#">B82Y30/00</a>
Alloys containing metallic or non-metallic fibres or filaments	<a href="#">C22C49/00</a>

Delete: The following table row symbol C22C49/44 from the Informative reference table:

Fibre reinforced metals	<a href="#">C22C49/44</a>
-------------------------	---------------------------

Replace: The existing description for symbol C08J5/00 with the following text:

Chemical aspects of manufacture of articles or shaped materials containing macromolecular substances	<a href="#">C08J5/00</a>
--	--------------------------



DATE: MAY 1, 2021

PROJECT RP0676

**Glossary of terms**

Replace: The entire Glossary table with the following revised table.

Fibre or fiber	General expression for a reinforcement in the form of a bundle of filaments.
Filament	Single reinforcing body of high aspect ratio, typically produced artificially by pressing a fluid through a small diameter orifice (spinneret) and allowing the fluid to solidify after leaving the spinneret and being subjected to cooling, drying or a chemical reaction. The filament can also come from a natural source (single filament of a plant or animal fibre).
Roving	Bundle of fibres or collection of a large number of filaments resulting in a bundle of substantially higher cross section than that of a single fibre.
Whisker	Typically a short length filament.

**B29C 70/30****References****Limiting references**

Delete: The entire Limiting references section and all table row.

Insert: The following new *Application-oriented references* section and table row.

**Application-oriented references**

*Examples of places where the subject matter of this place is covered when specially adapted, used for a particular purpose, or incorporated in a larger system:*

Producing fibrous preforms for subsequent moulding	<a href="#">B29B 11/16</a>
--	----------------------------

Insert: The following new *Informative references* section and table row.

**Informative references**

*Attention is drawn to the following places, which may be of interest for search:*

Specific details of the moulding process	<a href="#">B29C70/40</a> - <a href="#">B29C70/56</a>
--	--

**Special rules of classification**

Illustrative example of subject matter classified in [B29C70/305](#)

Replace: The existing figure with the following revised figure.

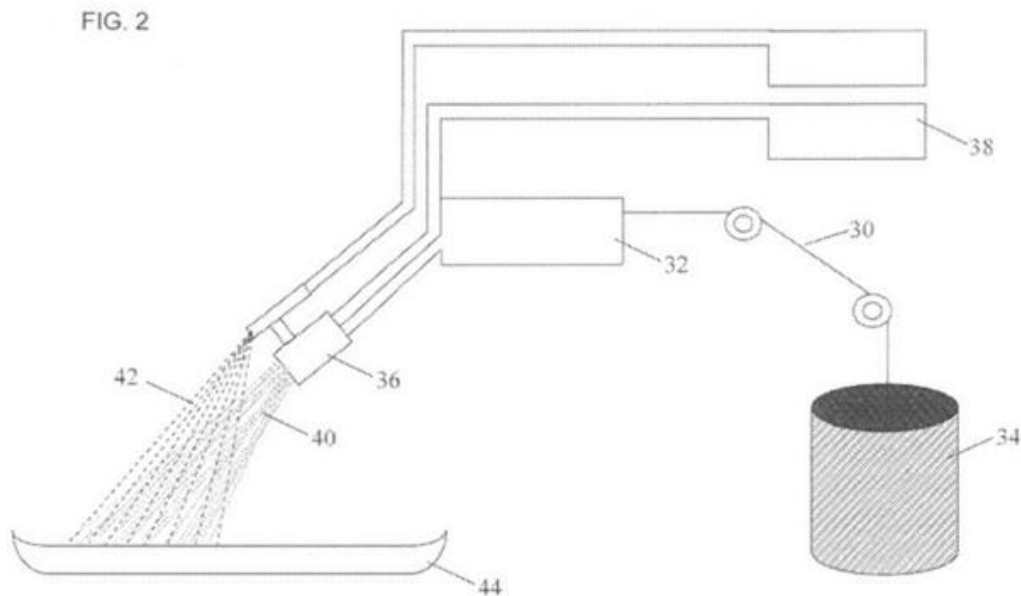

DATE: MAY 1, 2021

PROJECT RP0676

## **B29C 70/54**

### **Definition statement**

Replace: The terms “Positioning” and “Perforating” with the lower case spelling as shown below:

All details and auxiliary operations related to shaping of composites consisting of reinforcements only, e.g. sensing means to control curing, impregnation, positioning reinforcements in a mould, perforating, cutting or machining during or after moulding.

### **References**

#### ***Informative references***

Insert: The following new table row into the *Informative references* table.

Pre-treatment, e.g. impregnation, of reinforcements	<a href="#">B29B 15/08</a>
---	----------------------------

**Special rules of classification**

Illustrative example of subject matter classified in [B29C70/541](#):

Replace: The existing figure (first figure) with the following revised figure.

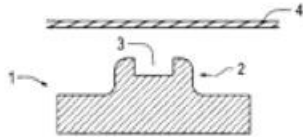

Fig. 1

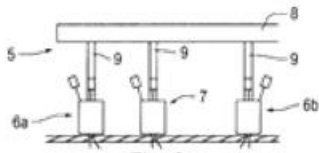

Fig. 2

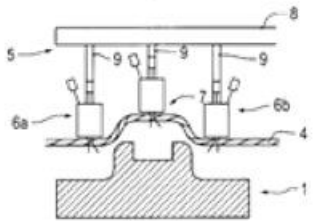

Fig. 3

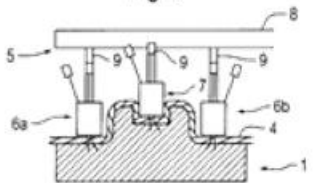

Fig. 4

DATE: MAY 1, 2021

PROJECT RP0676

Illustrative example of subject matter classified in [B29C70/542](#)

Replace: The existing figure (second figure) with the following revised figure.

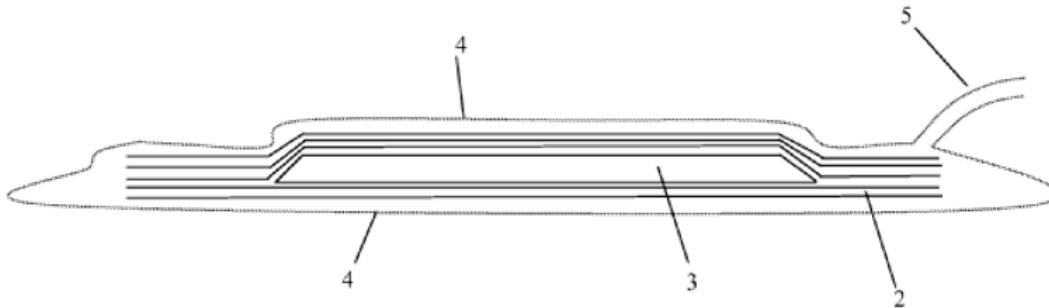

Replace: The existing paragraph text immediately following the header [B29C70/543](#)

e.g. local stitching, bonding, curing to avoid fibrous reinforcement from misaligning during moulding

with the following revised paragraph.

Documents that teach, e.g. local stitching, bonding, or curing to avoid fibrous reinforcement from misaligning during moulding belong here.

CPC NOTICE OF CHANGES 1070

DATE: MAY 1, 2021

PROJECT RP0676

Replace: The existing paragraph text immediately following the header [B29C70/545](#)

If an for the skilled person obvious mechanical post treatment is mentioned like e.g. deburring, sanding, removal of mould flash, the document should not be classified here. Only if the process contains such treatment which is not obvious for the skilled person, presented as part of the invention or if indispensable for the moulding method presented.

with the following revised paragraph:

If a document teaches mechanical post treatment that would be obvious to one of ordinary skill in the art, such as deburring, sanding or removal of mould flash, the document should not be classified here. A document should be classified here only if the process teaches treatment that is not obvious to one of ordinary skill in the art, and is taught as part of the invention or as indispensable for the moulding method presented.

CPC NOTICE OF CHANGES 1070

DATE: MAY 1, 2021

PROJECT RP0676

3. REVISION CONCORDANCE LIST (RCL)

<b>Type*</b>	<b>From CPC Symbol (existing)</b>	<b>To CPC Symbol(s)</b>
C	B29C 70/00	B29C 70/00, B29C 70/003, B29C 70/0035
C	B29C 70/30	B29C 70/30, B29C 70/302, B29C 70/304
C	B29C 70/46	B29C 70/46, B29C 70/461
C	B29C 70/54	B29C 70/54, B29C 70/544, B29C 70/549
C	B29D 99/0003	B29D 99/0003, B29D 99/0005

\* C = entries with modified file scope where reclassification of documents from the entries is involved; Q = new entries which are firstly populated with documents via administrative transfers from deleted (D) entries. Afterwards, the transferred documents into the Q entry will either stay or be moved to more appropriate entries, as determined by intellectual reclassification; D = deleted entries; F = frozen entries will be deleted once reclassification of documents from the entries is completed.

NOTES:

- Only C, D, F, and Q type entries are included in the table above.
- When multiple symbols are included in the “To” column, do not use ranges of symbols.
- For administrative transfer of documents, the following text should be used: “< administrative transfer to XX>”, “<administrative transfer to XX and YY simultaneously>”, or “<administrative transfer to XX, YY, ...and ZZ simultaneously>” when administrative transfer of the same documents is to more than one place.
- Administrative transfer to main trunk groups is assumed to be the source allocation type, unless otherwise indicated.
- Administrative transfer to 2000/Y series groups is assumed to be “additional information”.
- If needed, instructions for allocation type should be indicated within the angle brackets using the abbreviations “ADD” or “INV”: <administrative transfer to XX ADD>, <administrative transfer to XX INV>, or < administrative transfer to XX ADD, YY INV, ... and ZZ ADD simultaneously>.
- In certain situations, the “D” entries of 2000-series or Y-series groups may not require a destination (“To”) symbol, however it is required to specify “<no transfer>” in the “To” column for such cases.
- RCL is not needed for finalisation projects.

CPC NOTICE OF CHANGES 1070

DATE: MAY 1, 2021

PROJECT RP0676

4. CHANGES TO THE CPC-TO-IPC CONCORDANCE LIST (CICL)

<u>CPC</u>	<u>IPC</u>	<u>Action*</u>
B29C 70/003	B29C 70/00	NEW
B29C 70/0035	B29C70/00	NEW
B29C 70/302	B29C 70/30	NEW
B29C 70/304	B29C70/30	NEW
B29C 70/461	B29C 70/46	NEW
B29C 70/544	B29C 70/54	NEW
B29C 70/549	B29C 70/54	NEW
B29D 99/0005	B29D 99/00	NEW

\*Action column:

- For an (N) or (Q) entry, provide an IPC symbol and complete the Action column with “NEW.”
- For an existing CPC main trunk entry or indexing entry where the existing IPC symbol needs to be changed, provide an updated IPC symbol and complete the Action column with “UPDATED.”
- For a (D) CPC entry or indexing entry complete the Action column with “DELETE.” IPC symbol does not need to be included in the IPC column.
- For an (N) 2000 series CPC entry which is positioned within the main trunk scheme (breakdown code) provide an IPC symbol and complete the action column with “NEW”.
- For an (N) 2000 series CPC entry positioned at the end of the CPC scheme (orthogonal code), with no IPC equivalent, complete the IPC column with “CPCONLY” and complete the action column with “NEW”.

NOTES:

- F symbols are not included in the CICL table above.
- T and M symbols are not included in the CICL table above unless a change to the existing IPC is desired.