

H01M

PROCESSES OR MEANS, e.g. BATTERIES, FOR THE DIRECT CONVERSION OF CHEMICAL ENERGY INTO ELECTRICAL ENERGY

Definition statement

This place covers:

Constructional details or processes of manufacture of the non active parts, e.g. casings, mountings, vents, separators, current-conducting connections, arrangements for filling or emptying cases with or of liquid.

Electrodes composed of or comprising active material, processes of manufacture and active materials thereof, e.g. electrodes for primary cells, for lead-acid accumulator.

Inert electrodes with catalytic activity, processes of manufacture and catalytic materials thereof.

Primary cells, manufacture and servicing or maintenance thereof, e.g. cells with aqueous or non-aqueous electrolyte, deferred-action cells, printed batteries

Secondary cells, manufacture and servicing or maintenance thereof, heating or cooling; temperature control, e.g. lead-acid accumulators, alkaline accumulators, accumulators with non-aqueous electrolyte

Fuel cells or their stacks and manufacture thereof, e.g. alkaline fuel cell, polymer electrolyte fuel cell, solid oxide fuel cell, biochemical fuel cells comprising enzymes as catalysts

Combination of fuel cells with means for production of reactants, e.g. with reformer or for treatment of residues

Hybrid cells, e.g. Zinc-air battery, half-cell of a fuel cell type and half-cell of a primary or secondary cell type

Structural combinations of different types of electrochemical generators.

Relationships with other classification places

This subclass does not cover the preparations of chemical compounds as such, which subject matter is covered by classes [C01](#) (inorganic chemistry), [C07](#) (organic chemistry) and [C08](#) (organic macromolecular compounds).

Specific chemical compounds for batteries and their preparation are classified in [C01](#), [C07](#) and [C08](#) as well as in [H01M](#).

Apparatus for testing electrical condition of accumulator or batteries are classified in [G01R 31/36](#) and accumulators combined with arrangements for measuring, testing or indicating condition are classified in [H01M 10/48](#)

Electrochemical processes or apparatus otherwise than for generating energy [C25](#)

References

Informative references

Attention is drawn to the following places, which may be of interest for search:

Catalysts	B01J 23/00 , B01J 25/00 , B01J 27/00 , B01J 31/00
Disposal of solid waste	B09B

Working or processing of sheet metal or metal tubes	B21D
Casting of metals	B22D
Shaping of substances in a plastic state	B29C
Producing particular articles from plastics or from substances in a plastic state.	B29D
Arrangement or mounting of plural diverse prime-movers characterised by the electric storing means, e.g. batteries	B60K 6/28
Arrangement or mounting of plural diverse prime-movers characterised by the fuel cells	B60K 6/32
Electric propulsion using power supplied from primary cells, secondary cells or fuel cells	B60L 50/50
Arrangement of batteries specially adapted for vehicles	B60R 16/04
Supplying batteries to, or removing batteries from vehicles	B60S 5/06
Conjoint control of vehicle sub-units of different type including control of energy storage means, e.g. batteries	B60W 10/26
Conjoint control of vehicle sub-units of different type including control of fuel cells	B60W 10/28
Measuring or testing processes involving enzymes	C12Q 1/00
Electrodes for electrolytic processes	C25B 11/00 , C25C 7/00
Electrodes for electrolytic or electrophoretic process for the production of compounds or non metals	C25B 11/00
Diaphragms; spacing elements for electrolytic or electrophoretic process for the production of compounds or non metals	C25B 13/00
Electrodes for electrolytic production, recovery or refining of metals	C25C 7/02
Diaphragms; spacing elements for electrolytic production, recovery or refining of metals	C25C 7/04
Electrodes for electrolytic coating	C25D 17/10
Indicating or measuring liquid	G01F 23/00
Investigating or analysing materials by determining their chemical or physical properties	G01N
Apparatus for testing electrical condition of accumulator or electric batteries	G01R 31/36
Control of temperature	G05D 23/00
Electrolytes for electrolytic capacitors	H01G 9/022
Electrolytic light sensitive devices	H01G 9/20
Lithium-ion capacitors	H01G 11/06
Electrically conductive connections	H01R
Conversion of DC power input into DC power output using batteries	H02M 3/18
Photovoltaic modules structurally associated with energy storage means, e.g. batteries	H02S 40/38
Semiconductor or other solid state devices for converting light or heat into electrical energy	H10F 10/00 , H10F 19/00 , H10N 10/00 , H10N 15/00 , H10K 30/00

Special rules of classification

Every technical aspect of the invention is classified with inventive symbols and additional information from the description with additional symbols.

When the battery or fuel cell is characterised by the combination of a specific positive electrode, specific negative electrode and/or specific electrolyte: every specific component of the combination will be classified with inventive symbols.

When a breakdown Indexing Code represents the invention, the corresponding upper group should also be given.

When the type of battery is not mentioned, the classification of the invention is done in the primary and secondary type of battery classes.

When a group for a process does not exist, it is classified within the material of the object.

Additional orthogonal Indexing Codes are used for "additional information" and are always given together with a CPC group. Classification with these codes is highly desirable, since they provide an efficient search tool when combined with a CPC group.

They concern:

[H01M 2200/00](#) and subgroups : Safety devices for primary or secondary batteries

[H01M 2220/00](#) and subgroups : Batteries for particular applications

[H01M 2250/00](#) and subgroups : Fuel cells for particular applications; Specific features of fuel cell system

[H01M 2300/00](#) and subgroups : Electrolytes

Glossary of terms

In this place, the following terms or expressions are used with the meaning indicated:

Active materials, active masses, active liquids	materials, masses, liquids participating in the electrochemical reactions
Inert electrodes	Electrodes characterised by their catalytic activity
Primary cells	Cells, where the cell energy present in chemical form is not regenerated
Secondary cells, accumulator	Rechargeable cells, characterised by reversible electrochemical reactions
Battery	Device comprising one or more electrochemical cells
NTC, PTC	NTC (negative temperature coefficient) thermistors with their resistance decreasing with increasing temperature, PTC (positive temperature coefficient) thermistors with their resistance rising with increasing temperature
Redox flow battery	Reversible fuel cell in which all electroactive components are dissolved in the electrolyte with a flow circulation system of the electrolyte
Redox fuel cell, indirect fuel cell	Fuel cell where the oxydant or fuel is not reacted directly at the electrode but with the reduced/oxidised form of a redox couple and the oxidised/reduced species are fed to cathode/anode

Synonyms and Keywords

Electrochemical storage device	Galvanic primary cell or secondary cell (battery, accumulator), electrochemical capacitors (in particular pseudocapacitors and hybrid capacitors)
--------------------------------	---

H01M 4/00

Electrodes

Definition statement

This place covers:

Electrodes comprising active material for primary, secondary and hybrid cell and electrodes with catalytic activity for fuel cells.

Processes of manufacture of the electrodes, selection of substances as active materials, carriers or collectors, inactive substances as ingredients in the electrode, e.g. binder, conductive material

Relationships with other classification places

The production of active material used in batteries is not classified in [H01M](#) but in [C01B](#), [C01D](#), [C01F](#), [C01G](#), [C22C](#), [C04B 35/00](#)

References

Informative references

Attention is drawn to the following places, which may be of interest for search:

General process for applying liquids to obtain a coating with specific electrical properties	B05D 5/12
Processing of sheet metal	B21D
Casting of metals	B22D
Working metallic powder	B22F
Soldering, welding	B23K
Layered products	B32B
Nanostructures	B82B
Carbon	C01B 32/00
Compounds of alkali metals	C01D
Compounds of Be, Mg, Al, Ca, Sr, Ba, Ra, Th or rare earth metals	C01F
Compounds of manganese	C01G 45/00
Compounds of Nickel	C01G 53/00
Shaped ceramic products	C04B 35/00
Organic macromolecular compounds	C08G , C08L
Alloys	C22C
Coating metallic material, surface treatment of metallic material, e.g. vacuum evaporation	C23C , C23C 14/00
Electrodes for electrolytic processes	C25 , C25B 11/00 , C25C 7/02 , C25D 17/10

Informative references

Electrolytic or electrophoretic processes for the production of compounds or non-metals, electrodes for those process	C25B
Carbon filaments	D01F 9/12
Conductors characterised by the conductive materials	H01B 1/12
Magnetic materials	H01F

Special rules of classification

- Classification of electrode versus classification of active material ([H01M 4/38-H01M 4/60](#)) should only be given when the invention concern the combination of active material and non-active materials, information given on the different elements constituting the electrode.
- [H01M 4/02](#) is only employed if the subject to be classified is general and does not concern the subgroups [H01M 4/06](#), [H01M 4/13](#), [H01M 4/14](#), [H01M 4/24](#)
- The process of manufacture of a specific type of battery electrode is classified in [H01M 4/16-H01M 4/23](#) or [H01M 4/26-H01M 4/30](#) or [H01M 4/139-H01M 4/1399](#) and in [H01M 4/04-H01M 4/0428](#) (double classification).
- [H01M 4/02](#) and [H01M 4/04-H01M 4/0428](#) should not be used for fuel cell electrodes and their manufacture which are classified in [H01M 4/86-H01M 4/8896](#)
- All the steps of the process of the manufacture of an electrode (battery electrode or fuel cell electrode) should be classified if possible.
- When oxides are added in an electrode and when it's not sure whether it's an active material or an additive, classes in [H01M 4/48-H01M 4/57](#), [H01M 4/62](#) and [H01M 4/362](#) should be given
- [H01M 4/366](#) is used for any coating (the coating being a second active material or not). In the case the coating is not a second active material, [H01M 4/62](#) subgroup should be given.
- [H01M 4/364](#) is only used for mixture of at least 2 active materials.
- Classification of alloys under [H01M 4/38](#) relate to the composition before charging, e.g. before the addition of lithium.
- Electroactive polymers classified in [H01M 4/137](#) concern polymers where oxidation/reduction (redox) processes take place
- Electrode composed of Lithium or lithium based alloy is classified in [H01M 4/134](#)
- [H01M 4/18](#) relates to Planté electrode process. It concerns lead dioxide generated by direct oxydation of lead that forms the conducting substrate.
- Alkaline earth metals oxides or hydroxides, oxides or hydroxides of metal other than manganese, nickel, iron, cobalt, silver, lead, mercury are classified in [H01M 4/48](#) and if they insert or intercalate light metals, they are classified in [H01M 4/485](#).

H01M 4/82**Multi-step processes for manufacturing carriers for lead-acid accumulators****References****Informative references**

Attention is drawn to the following places, which may be of interest for search:

Single step processes	B21D , B22D
-----------------------	---

H01M 4/86

Inert electrodes with catalytic activity, e.g. for fuel cells

Definition statement

This place covers:

Electrodes for fuel cells, comprising catalysts

References

Informative references

Attention is drawn to the following places, which may be of interest for search:

Catalysts	B01J , B01J 23/38
Process for preparing catalyst	B01J 37/00

Special rules of classification

Catalysts supported on carbon are not classified in [H01M 4/96](#) but in [H01M 4/9083](#) or [H01M 4/926](#).

[H01M 4/96](#) is only given if carbon is the catalytic species, e.g. for hybrid cells.

[H01M 4/8647-H01M 4/8657](#) concern composite material, meaning comprising at least 2 catalysts having the same function and [H01M 4/8615](#) concerns bifunctional electrode used in regenerative fuel cell with oxygen reduction catalyst and oxygen evolution reaction catalyst.

All the steps of the process of the manufacture of a fuel cell electrode

should be classified if possible within subgroups [H01M 4/88-H01M 4/8896](#)

The process for making electrocatalyst are classified within the catalyst material subgroups [H01M 4/90-H01M 4/923](#). Catalysts used only in fuel cells are not classified in [B01J](#).

H01M 6/00

Primary cells; Manufacture thereof

Definition statement

This place covers:

- Primary batteries with aqueous electrolyte, non-aqueous electrolyte and solid electrolyte.
- primary batteries activated by addition of electrolyte, by physical means (thermal and mechanical)
- thin film or flat or printed primary batteries
- Methods or arrangements for maintenance of primary batteries including heating or cooling, primary batteries combined with cell condition or safety devices, regeneration of reactants or electrolyte, type recognition

References

Informative references

Attention is drawn to the following places, which may be of interest for search:

Thermoelectric solid state devices	H10N 10/00
------------------------------------	----------------------------

Special rules of classification

Classification for primary and secondary non aqueous batteries:

- When it concerns only primary battery : [H01M 6/162-H01M 6/188](#)
- When it concerns primary and secondary battery or in case of doubt : both subgroups are given : [H01M 6/162-H01M 6/188](#) and [H01M 10/056-H01M 10/0569](#)
- When it concerns only secondary battery : [H01M 10/056-H01M 10/0569](#)

Solid polymer electrolyte of a battery is not classified in [H01M 8/1018](#) unless the use in a fuel cell is mentioned.

Printed battery in [H01M 6/40](#) concern thin film battery.

Glossary of terms

In this place, the following terms or expressions are used with the meaning indicated:

Primary cells	Electrochemical generators in which the cell energy is present in chemical form and is not regenerated
---------------	--

H01M 6/36

containing electrolyte and made operational by physical means, e.g. thermal cells

References

Informative references

Attention is drawn to the following places, which may be of interest for search:

Thermoelectric solid state devices	H10N 10/00 , H10N 15/00
------------------------------------	---

H01M 8/00

Fuel cells; Manufacture thereof

Definition statement

This place covers:

Fuel cells or their stacks that can include:

- Collectors, separators, interconnectors, gas diffusion layer.
- Sealing or frame, its processes and materials.
- Membranes, matrices holding electrolytes solutions or melts.
- Means for temperature measurement or control, for reactant control or regulation.
- Methods for controlling fuel cells or fuel cell systems with detection and regulation of variables.
- Combination of fuel cells with means for production of reactants (e.g. with a reformer) or for treatment of residues.
- Types of fuel cell: with aqueous electrolytes (e.g. alkaline fuel cells), with solid electrolyte at low temperature (below 200-250°C) (e.g. polymer electrolyte fuel cells), with solid electrolyte at high temperature (e.g. solid oxide fuel cells), with molten electrolyte, biofuel cells/biochemical fuel cells comprising enzymes as catalysts.
- Manufacture thereof.

References

Informative references

Attention is drawn to the following places, which may be of interest for search:

Constructional details, or processes of manufacture, of the non-active parts of cells other than fuel cells	H01M 50/00
Separation of gases or vapour	B01D 53/00
Semi-permeable membranes	B01D 67/00 , B01D 69/00 , B01D 71/00
Catalysts	B01J 23/00 , B01J 25/00 , B01J 27/00 , B01J 31/00
Recycling of heat from fuel cell to other parts of a car	B60H 1/00278
Fuel cells used to drive air conditioning	B60H 1/00428
Prime movers consisting of electric motors and internal combustion engines characterised by the fuel cells	B60K 6/32
Electric propulsion using power supplied from fuel cells	B60L 50/50
Conjoint control of vehicle sub-units of different type including control of fuel cells	B60W 10/28
Arrangement or adaptations of fuel cells in cosmonautic vehicles	B64G 1/423
Hydrogen; Gaseous mixtures containing hydrogen; Separation of hydrogen from mixtures containing it; Purification of hydrogen	C01B 3/00
Shaped ceramic products (e.g. for use in solid oxide fuel cells)	C04B 35/00
Manufacture of shaped structures of ion-exchange resins	C08J 5/20
Production of combustibles gases containing carbon monoxide from solid carbonaceous fuels	C10J 3/00
Liquid carbonaceous fuels	C10L 1/00
Microorganisms or enzymes	C12N
Measuring or testing processes involving enzymes	C12Q 1/00
Diaphragms or spacing elements for electrolytic or electrophoretic process for the production of compounds or non-metals	C25B 13/00
Diaphragms or spacing elements for electrolytic production, recovery or refining of metals	C25C 7/04
Vessels for containing or storing compressed, liquefied or solidified gases	F17C
Burners for combustion of a gas	F23D 14/00
Gas-turbine combustion chambers	F23R
Electrochemical sensors	G01N 27/26
Apparatus for testing electric properties	G01R 31/00
Control of temperature	G05D 23/00
Electrolytes for electrolytic capacitors	H01G 9/022
Hybrid capacitors	H01G 11/00
Electrically conductive connections	H01R
Semi-conductor or other solid state devices for converting light or heat into electrical energy	H10F 10/00 , H10F 19/00 , H10N 10/00 , H10N 15/00 , H10K 30/00

Special rules of classification

- Electrodes for fuel cells are classified in [H01M 4/86- H01M 4/98](#).
- Membranes for immobilising electrolyte solutions or electrolyte melts are classified in [H01M 8/0289 -H01M 8/0295](#) and membranes used as support or mixed with polymer electrolytes are classified in [H01M 8/1058-H01M 8/1062](#).
- Means for control of temperature, pressure, reactant, and electrolyte are classified in subgroups [H01M 8/04007-H01M 8/04291](#) and methods for controlling fuel cells or fuel cell systems are classified in [H01M 8/04298-H01M 8/04992](#).
- Reactant in a fuel cell is only what is delivered immediately to the fuel cell, e.g. liquid methanol is evaporated to gaseous methanol that is used then in a fuel cell; only [H01M 8/04089](#) will be used.
- Means for preventing methanol crossover (gaseous or liquid methanol) are classified in [H01M 8/04197](#).
- [H01M 8/04119](#) concerns the humidification in the fuel cell.
- [H01M 8/04291](#) is used for water management of the fuel cell system.
- Rules for [H01M 8/04298-H01M 8/04992](#).
- When the claims refer to control and/or process/management of the fuel cell, then group symbols in [H01M 8/04298-H01M 8/04992](#) should be given and it's the description and claims (if they are clear) that are classified. Every variable really disclosed/claimed and not just listed as part of a whole list should be classified.
- If only general details are given in the detected and/or regulated variables, then the upper groups [H01M 8/04313](#) and/or [H01M 8/04694](#) should be given.
- When control/management is detailed only in the description, then classification symbols from [H01M 8/04298-H01M 8/04992](#) should be given as additional symbols.
- When the control of a fuel cell concerns the detection/measurement of environmental variables (e.g. temperature, pressure, humidity of the environment), classification in the group [H01M 8/0432](#) should be given if it concerns the detection of ambient temperature or in the group [H01M 8/0438](#) if it concerns ambient pressure.
- In a system with means for production of reactants or treatment of reactants or residues, if the fuel cell aspect is not the invention (only mentioned in the description or the last (sub)claim), the document should only be classified with an additional symbol [H01M 8/06](#).
- If the fuel cell in combination with the other means is the invention, then it is classified as invention in the subgroups under [H01M 8/06](#).
- [H01M 8/188](#) is only allocated for redox flow battery or secondary fuel cells, the redox couple being reversible or regenerated.
- [H01M 8/20](#) is only used for fuel cells with redox couple being irreversible.
- [H01M 8/24](#) subgroups are used when the invention concerns the stack of fuel cells as such.
- The symbols [H01M 8/083](#), [H01M 8/086](#), [H01M 2008/1095](#), [H01M 2008/128](#), [H01M 2008/1293](#), and [H01M 2008/147](#) should be used for further classification to indicate the type of fuel cell.
- Figures (c), (d) correspond to the group [H01M 8/2428](#), figures (e), (f) correspond to the group [H01M 8/2432](#), and figures (g), (h), (i), (j) correspond to the group [H01M 8/243](#).
- Moreover, figure (f) also corresponds to the group [H01M 8/2428](#) and figures (h), (j) also correspond to the group [H01M 8/2428](#) if the emphasis of the invention is on the arrangement of the unit cells on a support.

Glossary of terms

In this place, the following terms or expressions are used with the meaning indicated:

Porous separator	gas diffusion layer
Separator	bipolar plate, interconnector
Fuel cell	Electrochemical generator wherein the reactants are supplied from outside

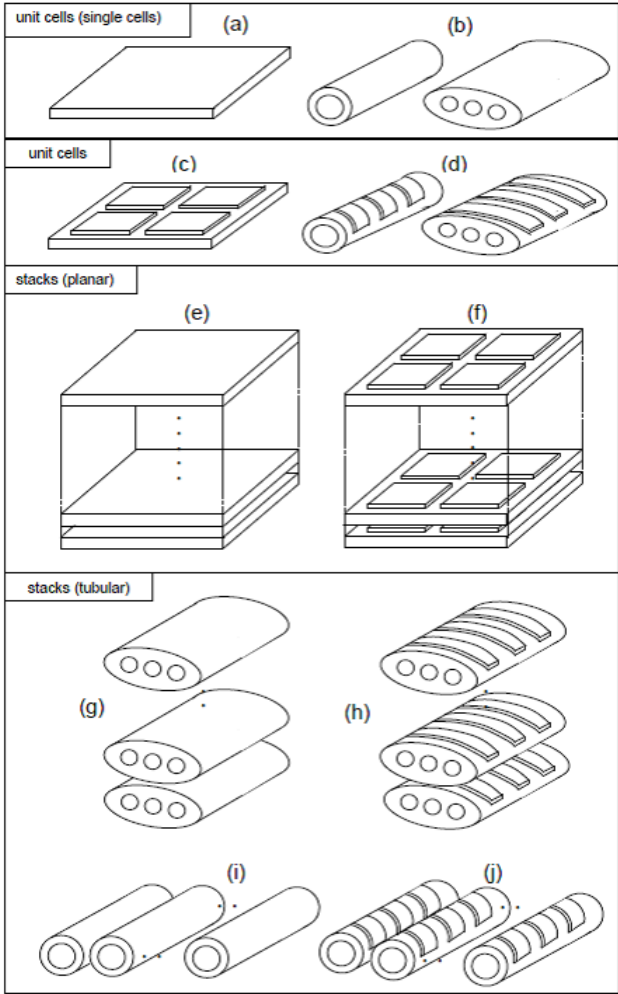
Single cell	Fuel cell entity, containing one single anode, one single electrolyte and one single cathode [see figure: (a), (b)]
Unit cell	Structural component, containing one or more single cells [see figure: (a), (b), (c), (d)]
Stack	Group of components, where the components (unit cells) are arranged in vertical direction [see figure: (e), (f), (g), (h)] and/or horizontal direction [see figure: (i), (j)]
Battery	Device comprising one or more electrochemical cells
Redox flow battery	Reversible fuel cell in which all electroactive components are dissolved in the electrolyte with a flow circulation system of the electrolyte
Redox fuel cell, indirect fuel cell	<p>Fuel cell where the oxidant or fuel is not reacted directly at the electrode but with the reduced/oxidised form of a redox couple and the oxidised/reduced species are fed to cathode/anode</p> <p>Figure:</p>  <p>The figure illustrates various configurations of fuel cell components:</p> <ul style="list-style-type: none"> unit cells (single cells): (a) shows a flat rectangular unit cell; (b) shows a cylindrical unit cell with internal components. unit cells: (c) shows a flat rectangular unit cell with internal structures; (d) shows a cylindrical unit cell with internal structures. stacks (planar): (e) shows a stack of flat rectangular unit cells; (f) shows a stack of flat rectangular unit cells with internal structures. stacks (tubular): (g) shows a stack of cylindrical unit cells; (h) shows a stack of cylindrical unit cells with internal structures. stacks (tubular): (i) shows a stack of cylindrical unit cells with internal structures; (j) shows a stack of cylindrical unit cells with internal structures and a flow channel.

Synonyms and Keywords

In patent documents, the following abbreviations are often used:

PEFC	Polymer Electrolyte Fuel Cell
------	-------------------------------

PEMFC	Proton Exchange Membrane Fuel Cell or Polymer Electrolyte Membrane Fuel Cell
SOFC	Solid Oxide Fuel Cell
AFC	Alkaline Fuel Cell
MCFC	Molten Carbonate Fuel Cell
DMFC	Direct Methanol Fuel Cell
PAFC	Phosphoric Acid Fuel Cell
MEA	Membrane Electrode Assembly

In patent documents, the following words/expressions are often used as synonyms:

- redox flow battery, regenerative fuel cell, and secondary fuel cell

H01M 8/06

Combination of fuel cells with means for production of reactants or for treatment of residues (regenerative fuel cells [H01M 8/18](#))

References

Limiting references

This place does not cover:

Regenerative fuel cells	H01M 8/18
-------------------------	---------------------------

Special rules of classification

The combination of fuel cell with means for production of reactants, e.g. reformer or for treatment of residues, e.g. removal of sulfur will be classified in [H01M 8/06](#) subgroups.

If the invention concern specifically the mean associated with the fuel cell, the means is classified and the aspect of the combination of the fuel cell with that mean is classified in [H01M 8/06](#) subgroups as additional symbol.

Temperature control means of a system combining fuel cell and for example a reformer will be classified in [H01M 8/06](#) subgroups, [H01M 8/04298](#) subgroups and in [C01B 3/02](#) subgroups if the temperature control concerns the reformer.

Every means in a combination system will be classified as invention or additional symbol according to the specific aspect of the invention, e.g. emphasis on the system or on a specific mean.

H01M 8/0618

{Reforming processes, e.g. autothermal, partial oxidation or steam reforming}

Relationships with other classification places

Reformers are classified in [C01B 3/02](#) subgroups

Special rules of classification

In a system comprising fuel cell and reformer, if the invention concerns only the reformer, the reformer will be classified in [C01B 3/02](#) subgroups and the fuel cell (minor aspect) will be classified with [H01M 8/06](#) as additional symbol.

If the invention concerns the whole system, then the invention is classified in [H01M 8/06](#) subgroups.

H01M 10/00

Secondary cells; Manufacture thereof

Definition statement

This place covers:

Construction in general.

Several types of secondary batteries : lithium batteries, lead acid batteries, alkaline batteries, high temperature batteries.

Methods or arrangements for servicing or maintenance.

Cooling, heating, regulating temperature.

Recycling.

Relationships with other classification places

Circuits for charging or depolarising or for supplying loads from batteries are classified in [H02J 7/00-H02J 7/36](#) and the methods for charging or discharging are classified in [H01M 10/44-H01M 10/445](#).

Measuring electric variables are classified in [G01R 31/36](#) if the measurement device is not structurally combined with the battery

Air conditioner of a car classified in [B60H](#) is also classified under [H01M 10/60-H01M 10/667](#) if it's used for cooling/heating a battery.

References

Informative references

Attention is drawn to the following places, which may be of interest for search:

Heating, cooling or ventilation devices in vehicles	B60H , B60H 1/00278
Arrangement of electric storage means for propulsion	B60K 1/04
Prime movers consisting if electric motors and internal combustion engines	B60K 6/28
Vehicles using power form primary cells, secondary cells or fuel cells	B60L 50/50
Arrangement of batteries in a vehicle	B60R 16/04
Supplying batteries to, or removing batteries from vehicles	B60S 5/06
Specific uses or applications of nanostructures	B82Y
Electrochemical actuator	F03G 7/012
Heat exchange or heat transfer apparatus	F28B , F28C , F28D , F28F
Indicating or measuring liquid in general	G01F 23/00
Investigating fluid tightness of structure	G01M 3/00
Measuring density	G01N 9/00
Investigating or analysing materials by the use of electric, electrochemical or magnetic means	G01N 27/26
Control of temperature in general	G05D 23/00
Arrangement for obtaining electrical energy form radioactive source	G21H 1/04

Semi-conductors devices	H01L
Generators in which kinetic energy is converted into electrical energy	H02N 3/00
Portable receivers and arrangement for mounting batteries or batteries chargers	H04B 1/3883
Portable phone with battery compartment	H04M 1/0262
Printed circuits	H05K

Special rules of classification

- Small-sized batteries indicate batteries used in portable devices
- Large-sized batteries indicate batteries used in vehicles or standby power.
- Construction classes under [H01M 10/12](#), [H01M 10/28](#), [H01M 10/058](#), [H01M 10/38](#) take precedence over [H01M 10/04](#).
- For non-aqueous secondary battery, a class indicating the type of battery, e.g. [H01M 10/052](#) should always be given in addition to the classes related to construction [H01M 10/058](#) - [H01M 10/0587](#) or to the classes related to the type of electrolyte [H01M 10/056](#)-[H01M 10/0569](#).
- Solid polymer electrolyte of a battery is not classified in [H01M 8/1018](#)-[H01M 8/1093](#) unless the use of this polymer in a fuel cell is indicated.
- Special rules for the subgroups [H01M 10/42](#)-[H01M 10/488](#)
- Additives in electrolyte having the function of safety are classified in [H01M 10/0567](#) for example and also in [H01M 10/4235](#). Fusing, polymerising additives are also classified in [H01M 10/4235](#).
- Structurally combination indicates attached to the battery or in the battery housing.
- Printed circuits integrated to the outside of the casing of the battery, e.g. on the cover) are classified in [H01M 10/425](#)
- [H01M 10/4257](#) concern battery with incorporated memory, microchip, electronic circuit inside the housing of the cells or batteries.
- The use of printed circuit as a casing of a battery is classified in [H01M 50/20](#).
- Apparatus for testing the cell or battery and not incorporated with the battery is classified in [H01M 10/4285](#)
- The regeneration of electrolyte or reactants done by non electrical means is classified in [H01M 10/4242](#)
- Any ratio between electrode/electrolyte, anode/cathode of a secondary battery is classified in [H01M 2010/4292](#)
- Removing gas inside the battery by water recombination is classified in [H01M 10/52](#).
- Gel electrolytes are double classified in [H01M 10/0565](#) if they concern gel-type polymeric material for non-aqueous accumulator and [H01M 2300/0085](#)

Glossary of terms

In this place, the following terms or expressions are used with the meaning indicated:

Accumulator	secondary battery
Secondary cells	Accumulators receiving and supplying electrical energy by means of reversible electrochemical reactions

H01M 10/48

Accumulators combined with arrangements for measuring, testing or indicating the condition of cells, e.g. the level or density of the electrolyte (constructional details of current conducting connections for detecting conditions inside cells or batteries, e.g. details of voltage sensing terminals, [H01M 50/569](#))

References

Limiting references

This place does not cover:

Constructional details of current conducting connections for detecting conditions inside cells or batteries, e.g. of voltage sensing terminals	H01M 50/569
--	-----------------------------

Informative references

Attention is drawn to the following places, which may be of interest for search:

Methods for charging or discharging	H01M 10/44
Indicating or measuring level of liquid in general	G01F 23/00
Measuring density	G01N , G01N 9/00
Measuring electric variables	G01R 31/36

H01M 12/00

Hybrid cells; Manufacture thereof (hybrid capacitors [H01G 11/00](#))

Definition statement

This place covers:

hybrid cells, e.g. half-cell of fuel cell type and half-cell of primary or secondary cell type:

- half cell of capacitor type and half-cell of primary or secondary battery type
- half cell of fuel cell type and half cell of primary or secondary cell type

Relationships with other classification places

Solid electrolytic capacitors, double-layer capacitors, are classified in [H01G 11/00](#)

References

Limiting references

This place does not cover:

Hybrid capacitors; Electric double-layer [EDL] capacitors	H01G 11/00
---	----------------------------

Special rules of classification

- If the invention concern electrodes, classes of fuel cell electrodes ([H01M 4/86-H01M 4/98](#)) and/or battery electrodes ([H01M 4/02-H01M 4/84](#)) are given in combination with the Indexing Code of the hybrid cells.
- The casing and the lid of the hybrid cells are classified in [H01M 50/1385](#) and [H01M 50/1537](#) respectively.

- Methods or arrangements for servicing or maintenance are classified in [H01M 6/50](#) or [H01M 10/42](#) according to the type of half battery cell. The control of half fuel cell type is classified under [H01M 8/04298-H01M 8/04992](#).
- All hybrid cell concerning half capacitor, half battery should be circulated to [H01G](#).

Glossary of terms

In this place, the following terms or expressions are used with the meaning indicated:

Hybrid cells	Electrochemical generators having two different types of half-cells, the half-cell being an electrode-electrolyte combination of either a primary, a secondary, or a fuel cell
--------------	--

H01M 12/04

composed of a half-cell of the fuel-cell type and of a half-cell of the primary-cell type

References

Informative references

Attention is drawn to the following places, which may be of interest for search:

Methods or arrangements for servicing or maintenance	H01M 6/50
--	---------------------------

H01M 12/08

composed of a half-cell of a fuel-cell type and a half-cell of the secondary-cell type

References

Informative references

Attention is drawn to the following places, which may be of interest for search:

Methods or arrangements for servicing or maintenance, e.g. for charging	H01M 10/42
---	----------------------------

H01M 14/00

Electrochemical current or voltage generators not provided for in groups [H01M 6/00](#) - [H01M 12/00](#); Manufacture thereof

Definition statement

This place covers:

Every type of electrochemical cell that is not classified in the above groups.

Photoelectrochemical storage cells wherein the light causes a change in chemistry and the energy is stored and discharged at later stage.

Relationships with other classification places

Solar cells are classified in [H01G 9/20](#) and only if the energy produced by the solar cell is stored then it will be also classified in [H01M 14/005](#).

References

Limiting references

This place does not cover:

Light sensitive devices (photocells)	H01G 9/20
--------------------------------------	---------------------------

Synonyms and Keywords

In patent documents, the following words/expressions are often used as synonyms:

- "photocells", "photoelectrochemical cells (PEC)", "photovoltaic cells" and "solar cells"

H01M 14/005

{Photoelectrochemical storage cells (light sensitive devices [H01G 9/20](#), semiconductors sensitive to light [H10F](#))}

Definition statement

This place covers:

Photoelectrochemical storage cells wherein the light causes a change in chemistry and the energy is stored and discharged at later stage.

Relationships with other classification places

This group does not cover solar cells, photocells, photoelectrochemical cells or photovoltaic cells which are covered by the following groups:

- Semiconductor devices sensitive to light and adapted for the conversion of the energy of such radiation into electrical energy are covered by group [H10F](#), [H10F 10/00](#), [H10F 19/00](#)
- Solid-state devices using organic materials as active part specially adapted for sensing light and adapted for the conversion of the energy of such radiation into electrical energy are covered by group [H10K 30/00](#)
- Electrolytic light sensitive devices, e.g. dye-sensitised solar cells, are covered by group [H01G 9/20](#)
- Photovoltaic modules structurally associated with energy storage are covered by group [H02S 40/38](#)

References

Limiting references

This place does not cover:

Electrolytic light sensitive devices	H01G 9/20
Photovoltaic modules structurally associated with energy storage	H02S 40/38
Semiconductor devices sensitive to light	H10F 10/00 , H10F 19/00
Solid-state devices using organic parts specially adapted for sensing light	H10K 30/00

H01M 16/00

Structural combinations of different types of electrochemical generators

Definition statement

This place covers:

Association of fuel cells with other electrochemical generators, e.g. fuel cell + electrolysers, fuel cell+ battery, fuel cell + capacitor

References

Limiting references

This place does not cover:

Combination of secondary battery with capacitor	H01M 10/4264
---	------------------------------

H01M 16/003

{of fuel cells with other electrochemical devices, e.g. capacitors, electrolysers}

Definition statement

This place covers:

Association of fuel cells with other electrochemical generators, e.g. fuel cell + electrolysers, fuel cell+ battery, fuel cell + capacitor

H01M 50/00

Constructional details or processes of manufacture of the non-active parts of electrochemical cells other than fuel cells, e.g. hybrid cells

Definition statement

This place covers:

Constructional details of non-active parts of batteries, or details of their manufacture. Such parts may include:

- Primary and secondary casings, jackets or wrappings, lids or covers, carrying devices, racks, mountings, holders, fixing devices;
- Vents, vent plugs, mechanical arrangements for allowing the escape of gas;
- Separators, diaphragms, spacing elements inside a primary casing;
- Current-conducting connections for terminals for cells, means for affording protection against corrosion or for preventing undesired use;
- Arrangements or processes for filling or topping-up casings with liquid, arrangements or processes for draining liquids from casings;
- Arrangements for stirring or circulating electrolytes.

References

Informative references

Attention is drawn to the following places, which may be of interest for search:

Constructional details or processes of manufacture of the non-active parts of fuel cells	H01M 8/00
--	---------------------------

Informative references

Electrically operated smoking devices; Component parts thereof; Manufacture thereof; Maintenance or testing thereof; Charging means specially adapted therefor	A24F 40/00
Electrotherapy, e.g. implantable medical devices	A61N
Working or processing of sheet metal or metal tubes	B21D
Casting of metals	B22D
Tools for drilling machines	B23B 51/00
Portable power-driven tools	B25F
Shaping of substances in a plastic state	B29C
Producing particular articles from plastics or from substances in a plastic state	B29D
Arrangement of batteries specially adapted for vehicles	B60K 1/04
Supplying batteries to, or removing batteries from vehicles	B60S 5/06
Container for batteries	B65D 2585/88
Diaphragms; spacing elements for electrolytic or electrophoretic process for the production of compounds or non-metals	C25B 13/00
Diaphragms; spacing elements for electrolytic production, recovery or refining of metals	C25C 7/04
Sealing	F16J 15/00
Valves	F16K
Apparatus for testing electrical condition of accumulators or electric batteries	G01R 31/36
Electrically conductive connectors connecting the battery to the load or electric system	H01R

Glossary of terms

In this place, the following terms or expressions are used with the meaning indicated:

primary casing	casing containing the electrochemical cell, i.e. arranged closest to the electrodes, the electrolyte and any separators
secondary casing	housing/casing/structure comprising or enveloping one or more primary casing(s)
single cell, battery	a cell is a primary casing containing a single electrochemical cell. A battery is a primary casing containing more than one cell. The term "battery" is sometimes loosely used to mean a single cell
battery pack, module	secondary casing containing one (or more) (single) cell(s) or batteries
button cell, coin cell	cells having a button- or coin-shaped casing, often of circular, elliptical or polygonal shape, and having a height-to-width ratio of less than 1
pouch or flexible bag	generally made of a flexible multi-layered laminate sheet sealed along at least an overlapping edge
jacket, wrapping	additional layer of material around at least a portion of a primary casing; not intrinsically formed with primary casing; generally having an additional functionality such as displaying information, additional external protection

separator, diaphragm	an electronically insulating, but ion-permeable porous body to be arranged between two electrochemically active electrodes; a separator or diaphragm may also be used for preventing liquids from being intermixed, e.g. in redox flow batteries
spacer, spacing element	an inert object to be arranged between two other objects for keeping a defined distance there between; usually electronically insulating; can be placed inside or outside primary casing battery; to be clearly distinguished from a separator by its positioning if inside a primary casing
terminal	electrical contact exposed at and accessible from the outside of a primary or secondary casing
interconnector	external electrical contacting element between terminals on a battery case (including primary and secondary cases)

Synonyms and Keywords

In patent documents, the following abbreviations are often used:

[PCB]	Printed circuit board
-------	-----------------------

H01M 50/102

characterised by their shape or physical structure

Definition statement

This place covers:

Any primary casing characterised by shape or physical structure, e.g. cable-shaped casings being intrinsically flexible and having a height to diameter (or width) ratio of approximately 10 or more.

H01M 50/103

prismatic or rectangular ([H01M 50/109](#), [H01M 50/11](#) take precedence)

Definition statement

This place covers:

Prismatic or rectangular casings that are generally hard, rigid casings often comprising a distinct lid. The edges may also be rounded.

Illustrative examples of prismatic or rectangular shaped casing (50 of first drawing and 34 of second drawing):

1.

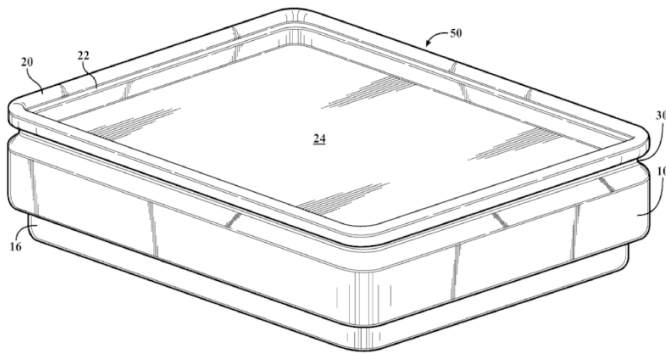

2.

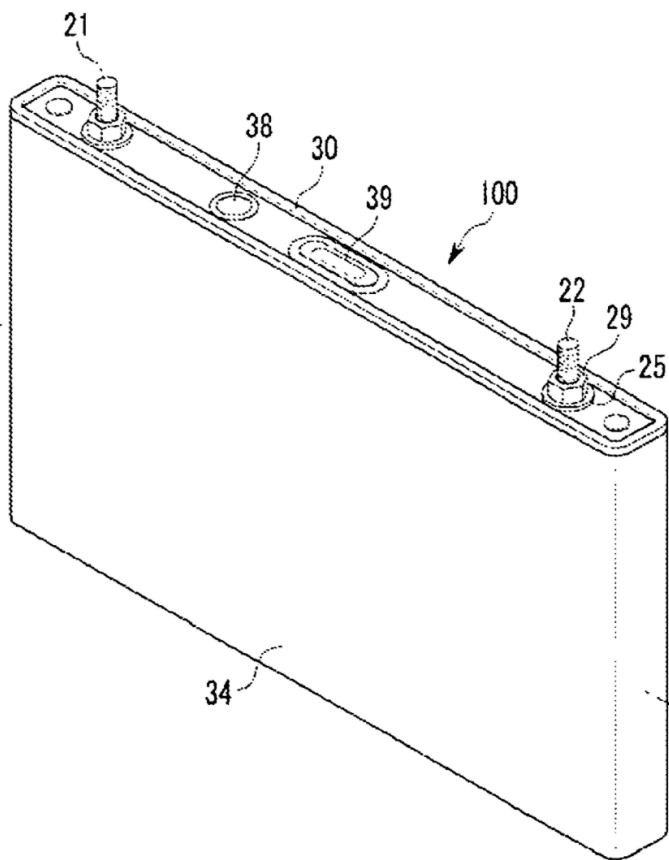

References

Limiting references

This place does not cover:

Primary casings of button or coin shape	H01M 50/109
Primary casings having a structure in the form of a chip	H01M 50/11

H01M 50/105

Pouches or flexible bags

Definition statement

This place covers:

Casings of pouch cells or flexible bag cells generally made of a flexible multi-layered laminate sheet sealed along at least an overlapping edge.

Illustrative example of pouch type battery casing (111-113a):

1.

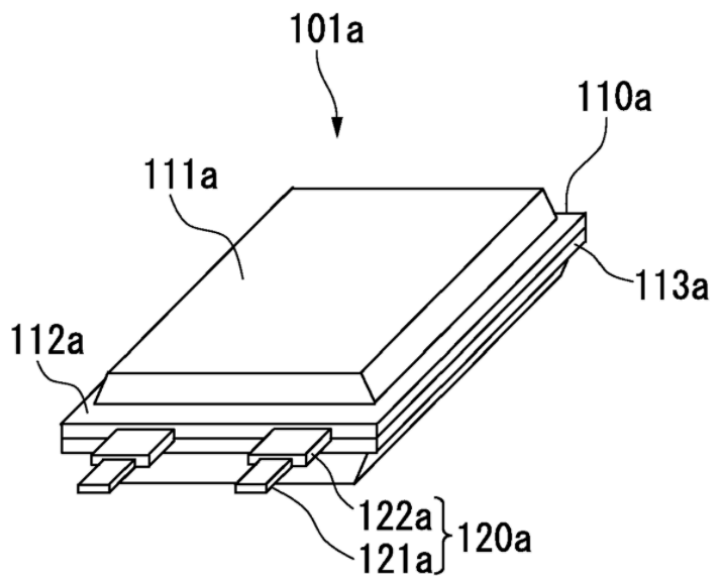
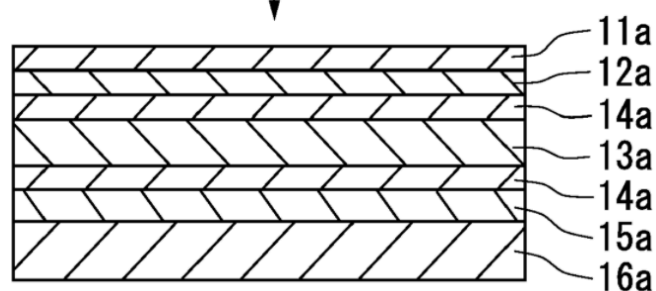

FIG. 10



H01M 50/109

of button or coin shape

Definition statement

This place covers:

Button or coin-shaped casings having a cylindrical or an elliptical shape, and, further, having a height to diameter ratio of less than 1.

Illustrative example of a button or coin shaped casing (101, 102):

1.

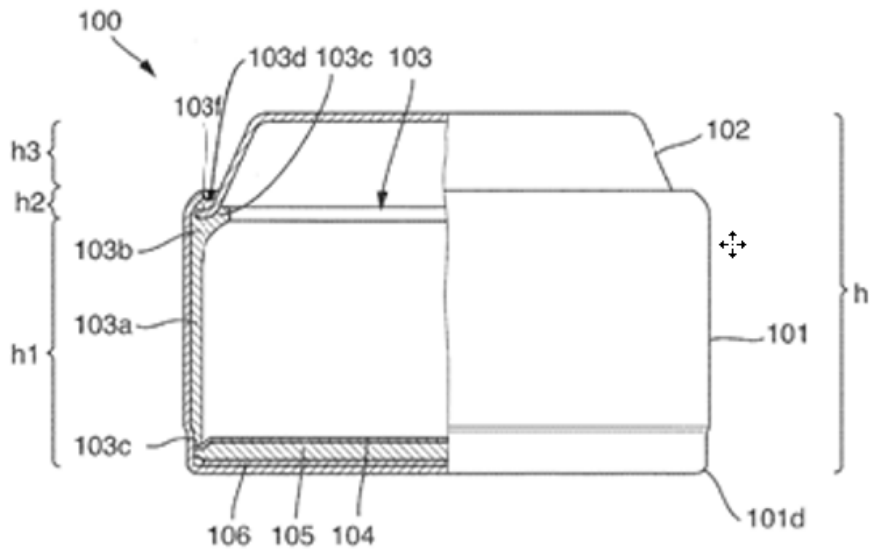

H01M 50/11

having a chip structure, e.g. micro-sized batteries integrated on chips

Definition statement

This place covers:

Structures of micro-sized batteries and miniature power sources integrated on chips, e.g. structures of thin-film micro lithium-ion batteries or rolled-up microtube lithium-ion batteries.

Illustrative example of a casing having a chip structure:

1.

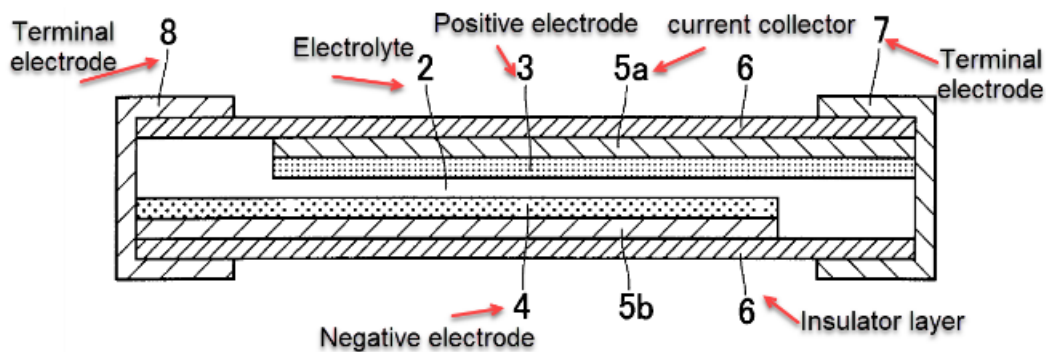

H01M 50/112

Monobloc comprising multiple compartments

Definition statement

This place covers:

Casings consisting of an integral housing with multiple compartments for holding bare electrochemical cells.

Illustrative example of monobloc casing (106) with multiple compartments (122):

1.

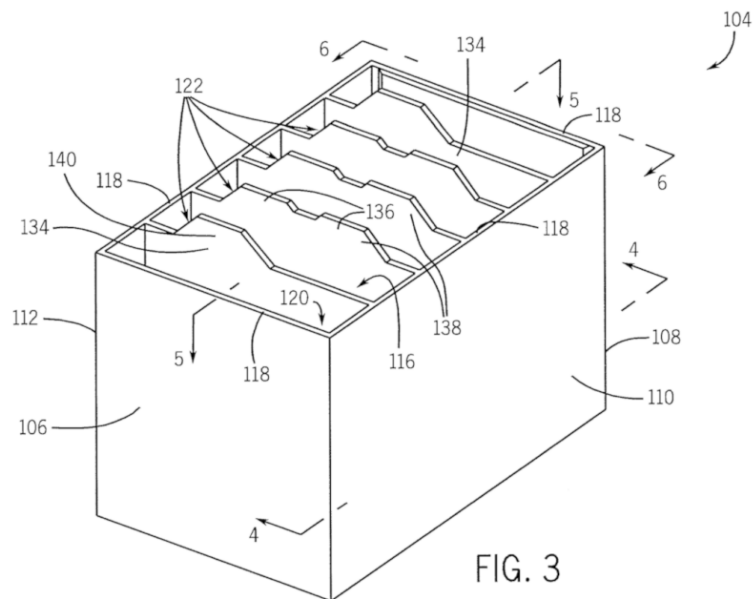

H01M 50/124

having a layered structure

Special rules of classification

Classification of multilayered casings, jackets or wrappings in this group or in groups [H01M 50/126](#), [H01M 50/128](#) or [H01M 50/129](#) requires consideration of the number of layers present.

In multilayered objects, adhesive layers are not considered as distinct layers for determining the number of layers.

Any layer providing functionality beyond simple adhesion should be counted as a distinct layer.

Layered structures are further classified according to the material of each layer, e.g. a layered structure comprising a metal layer should be classified in [H01M 50/119](#) and [H01M 50/124](#).

H01M 50/128

with two or more layers of only inorganic material

Definition statement

This place covers:

Casings comprising three or more layers with two or more layers of only inorganic material.

Illustrative example:

1.

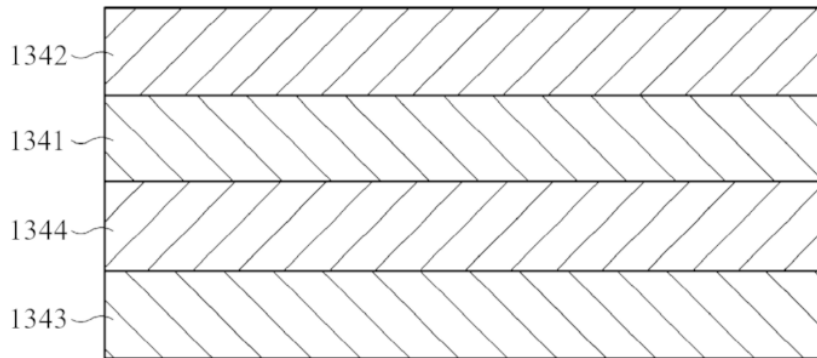

A pouch for a battery may be formed as a layer structure. The layer structure may include an outermost surface protection layer 1342 made of a first polymer and an innermost sealant layer 1343 made of a second polymer. A gas barrier layer 1341 made of a metal and a heat dissipation layer 1344 made of a ceramic may be stacked between the outer and inner layers.

The pouch of this example is classified in [H01M 50/128](#) and in [H01M 50/129](#).

H01M 50/129

with two or more layers of only organic material

Definition statement

This place covers:

Illustrative example:

1.

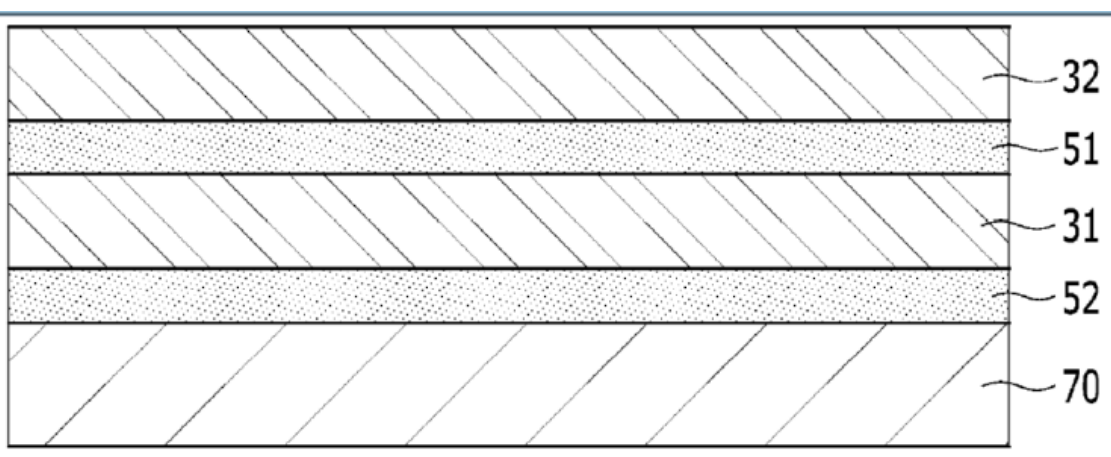

An outer case for a secondary battery may include a first polymer resin layer 31, a second polymer resin layer 32 disposed on a first surface of the first polymer resin layer 31 and attached by interposing a first adhesive layer 51, and an inner resin layer 70 disposed on a second surface of the first polymer resin layer 31 and attached by interposing a second adhesive layer 52, wherein each of the first polymer resin layer and the second polymer resin layer comprises a fluorine-containing resin.

H01M 50/131

characterised by physical properties, e.g. gas permeability, size or heat resistance

Definition statement

This place covers:

Primary casings, jackets or wrappings of a single cell or a single battery characterised by physical properties such as flexibility or heat resistance.

Special rules of classification

Primary casings, jackets or wrappings with heat resistant properties related to protection against damage by fire or explosion caused by external factors are classified in [H01M 50/143](#).

H01M 50/138

adapted for specific cells, e.g. electrochemical cells operating at high temperature

Definition statement

This place covers:

Electrochemical cell operating at high temperatures, e.g. molten salt electrolyte batteries, thermal batteries or sodium sulfur batteries [NAS].

Air batteries, e.g. zinc air or lithium air batteries.

Deep sea batteries. Deferred-action cells.

Illustrative example:

A high temperature rechargeable electrochemical cell (10) may comprise a cell casing defining an anode compartment for containing an alkali metal anode and a cathode compartment containing a liquid electrolyte. The cell may have an operating temperature at which the anode and liquid electrolyte are molten. The anode compartment may be separated from the cathode compartment by a separator (16) comprising a solid electrolyte which is a conductor of ions of the alkali metal of the anode at the operating temperature of the cell. The casing may comprise a cathode cover (12) of sheet material enclosing the cathode-side surface of the separator and an anode cover (14) of sheet material enclosing the anode-side surface of the separator. The cathode cover and the anode cover may be electronically conductive and electronically insulated from each other and may respectively form a cathode terminal and an anode terminal of the cell.

1.

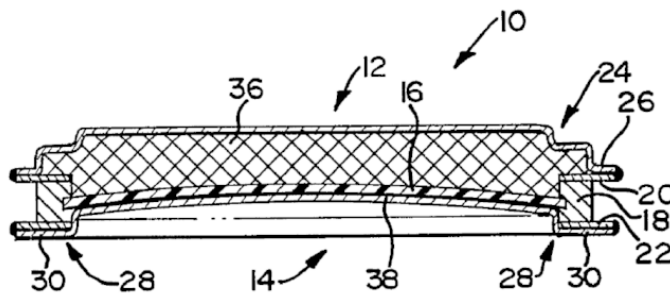

H01M 50/141

for protecting against humidity

Definition statement

This place covers:

Primary casings, jackets or wrappings for protecting against humidity or preventing the ingress of moisture, e.g. waterproofing wrappings.

H01M 50/143

Fireproof; Explosion-proof

Definition statement

This place covers:

Primary casings, jackets or wrappings for protecting against fire or explosion, e.g. thermally insulating layer for preventing a thermal runaway.

Example:

A battery comprising a fire-resistant sheet comprising a fire-resistant resin composition comprising an endothermic agent having a thermal decomposition onset temperature of 800°C or lower and an amount of heat absorbed of 300 J/g or larger, and a resin, a content of the endothermic agent per 100 parts by mass of the resin being 10 to 10000 parts by mass; and a battery cell, wherein the fire-resistant sheet is attached to the surface of the battery cell.

References

Informative references

Attention is drawn to the following places, which may be of interest for search:

Arrangements for facilitating escape of gases	H01M 50/30
---	----------------------------

Special rules of classification

Primary casings, jackets or wrappings with heat resistant properties not related to protection against damage by fire or explosion are classified in [H01M 50/131](#).

Glossary of terms

In this place, the following terms or expressions are used with the meaning indicated:

fireproof or fire-resistant material	material that withstands heat and prevents the spread of fire
heat-resistant material	material that remains unaffected by heat

H01M 50/145

for protecting against corrosion

Definition statement

This place covers:

The protection of primary casings against corrosion, e.g. the protection of metallic casings against corrosion caused by water.

Special rules of classification

Documents related to corrosion resistance and protection against humidity are classified in [H01M 50/141](#) and [H01M 50/145](#).

H01M 50/148

characterised by their shape

Special rules of classification

In the subgroups, lids or covers are classified according to the geometrical shape of the primary casing.

In the below example, the circular lid is classified in [H01M 50/103](#) as it concerns prismatic cells.

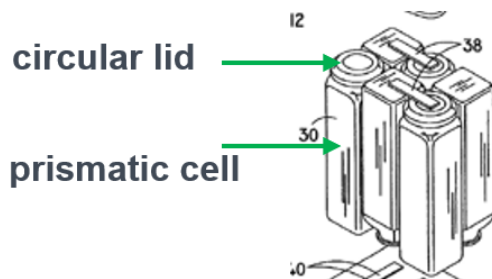

A lid or cover for a chip-shaped casing is classified in [H01M 50/148](#).

H01M 50/167

by crimping

Definition statement

This place covers:

Methods of assembling casing with lid by crimping.

Illustrative example:

1.

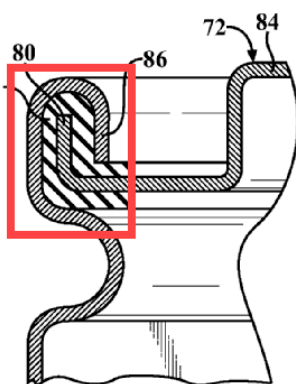

The upper part of the casing (86) is assembled with the lid (80) by crimping.

H01M 50/169**by welding, brazing or soldering****Definition statement**

This place covers:

Methods of assembling casing with lid by welding, brazing or soldering.

The welding processes concern welding metal to metal and the fusion of plastic materials.

H01M 50/198**characterised by physical properties, e.g. adhesiveness or hardness****Definition statement**

This place covers:

Primary casings, jackets or wrappings of a single cell or a single battery characterised by physical properties of the sealing material and supported by numerical values or exemplifying the solution of the problem to be solved, e.g. adhesiveness.

H01M 50/20**Mountings; Secondary casings or frames; Racks, modules or packs; Suspension devices; Shock absorbers; Transport or carrying devices; Holders (structural combination of accumulators with charging apparatus [H01M 10/46](#))****Definition statement**

This place covers:

Constructional details or processes of manufacture. Such details may include:

- Secondary casings, modules, packs, racks, holders;
- Suspension devices, shock absorbers, transport or carrying devices;
- Materials;
- Adaptation to shape of encompassed primary casing batteries;
- Physical properties of casings or racks;
- Methods of mounting;
- Lids or covers for racks or secondary casings;
- Details of integrating PCBs;
- Spacing elements;
- Fastening means; or
- Terminals of battery packs.

References**Limiting references**

This place does not cover:

Structural combination of accumulators with charging apparatus	H01M 10/46
--	----------------------------

Application-oriented references

Examples of places where the subject matter of this place is covered when specially adapted, used for a particular purpose, or incorporated in a larger system:

Electrically operated smoking devices; Component parts thereof; Manufacture thereof; Maintenance or testing thereof; Charging means specially adapted therefor	A24F 40/00
Electrotherapy, e.g. implantable medical devices	A61N
Tools for drilling machines	B23B 51/00
Portable power-driven tools	B25F
Arrangement of batteries specially adapted for vehicles	B60K 1/04
Adaptation of battery structures of electric vehicles, e.g. integration into control or safety systems, crash-resistant casings or vibration-damping means	B60L 50/64
Exchange of the energy storage elements for electric vehicles	B60L 53/80
Supplying batteries to, or removing batteries from, vehicles	B60S 5/06

H01M 50/202**Casings or frames around the primary casing of a single cell or a single battery****Definition statement**

This place covers:

Constructional details or processes of manufacture of secondary casings or frames around the primary casing of a single cell or a single battery.

Illustrative example of a single primary battery housed in a secondary casing:

1.

Fig. 16

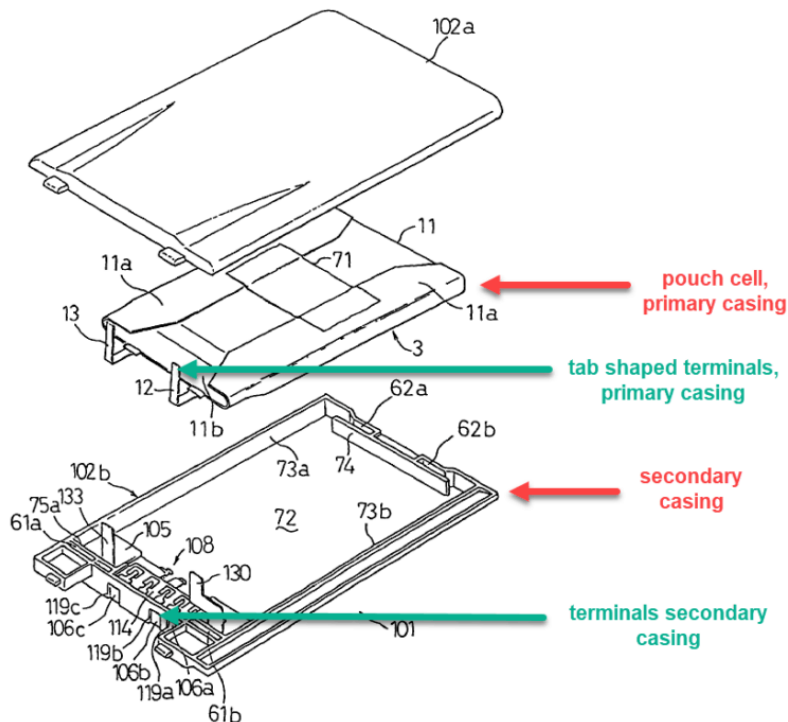

H01M 50/233

characterised by physical properties of casings or racks, e.g. dimensions

Special rules of classification

Physical properties should only be classified if supported by numerical values or exemplifying the solution of the problem to be solved (e.g. flexibility, foldability; protection against vibrations/impact/swelling).

H01M 50/244

Secondary casings; Racks; Suspension devices; Carrying devices; Holders characterised by their mounting method

Definition statement

This place covers:

Methods and mounting arrangements for secondary casings, racks, suspension devices, carrying devices and holders per se.

The mounting of cells or batteries within these casings, racks, etc.

Special rules of classification

Methods and arrangements for mounting secondary casings, racks, etc. in finished products, e.g. appliances or vehicles, are classified in [H01M 50/247](#), [H01M 50/249](#), [H01M 50/251](#) if the invention relates to the battery casings.

Methods of mounting casings in finished products such as appliances or cars are classified in places appropriate to the finished product if the invention relates to the product, appliance or vehicle.

H01M 50/249

specially adapted for aircraft or vehicles, e.g. cars or trains (constructional details of batteries specially adapted for electric vehicles [B60L 50/64](#))

Definition statement

This place covers:

Illustrative example:

1.

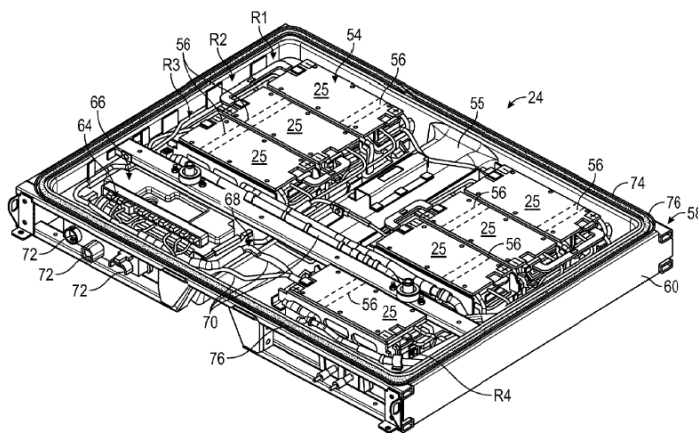

Battery pack 24 that can be used in an electric vehicle.

The battery pack 24 include a battery system 54 housed in a housing assembly 58. The housing assembly 58 may be a sealed housing, and may be embodied in any size, shape, and configuration within the scope of the present disclosure. In an embodiment, the housing assembly 58 includes a tray 60 and a cover. During assembly, the battery system 54 can be positioned within the tray 60, and then the cover can be fixedly secured to the tray 60 to seal the battery system 54 therein (discussed further below). The tray 60 and the cover can be made of any material or combination of materials, including metal and/or polymer materials.

The battery system 54 includes a plurality of battery cells 56 that store energy used to power various electrical loads of the electric vehicle 12. The battery cells 56 of the battery system 54 may be stacked side by side to form a group of battery cells 56, sometimes referred to as a battery array. In the embodiment, the battery cell 56 is a prismatic lithium ion battery cell.

The battery system 54 depicted in the figure above includes a plurality of adjacent rows R1-R4 of the battery array 25. In the embodiment, for a total of seven battery arrays, the rows R1 to R3 of the battery system 54 each include two battery arrays, and the row R4 includes one battery array.

The battery array 25 may be arranged in the housing assembly 58 in any configuration. In an embodiment, adjacent battery arrays 25 of rows R1 to R3 are separated by structural beams 55 extending between opposing side walls of tray 60.

Relationships with other classification places

[B60L 50/64](#) covers adaptation of battery structures of electric vehicles, e.g. integration into control or safety systems, crash-resistant casings or vibration-damping means.

References

Limiting references

This place does not cover:

Constructional details of batteries specially adapted for electric vehicles	B60L 50/64
---	----------------------------

H01M 50/269

Mechanical means for varying the arrangement of batteries or cells for different uses, e.g. for changing the number of batteries or for switching between series and parallel wiring (methods or arrangements for servicing or maintenance [H01M 6/50](#), [H01M 10/42](#))

Definition statement

This place covers:

Illustrative example for switching between "in series" and "mixed" ("series-parallel") wiring by means of reconfigurable connection pins (40).

Illustrative examples:

1.

In-series" connection configuration

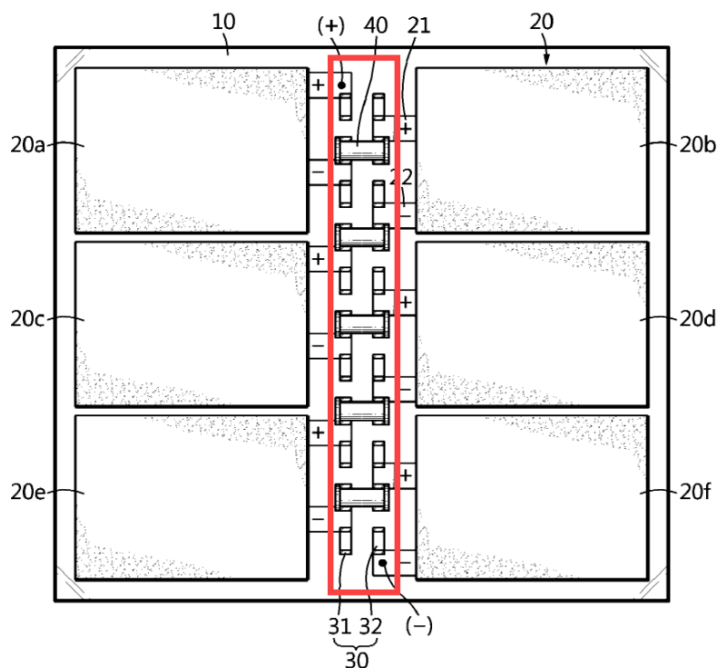

"Mixed" connection configuration

2.

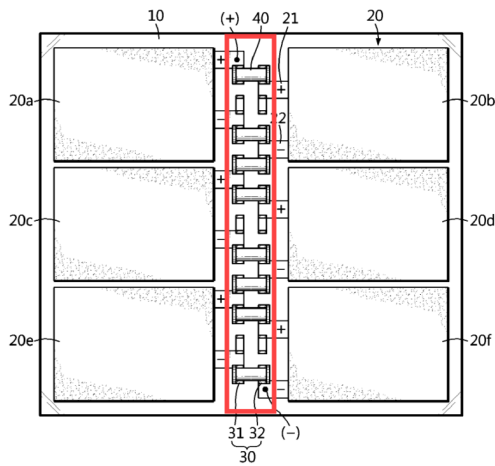

References

Limiting references

This place does not cover:

Methods or arrangements for servicing or maintenance	H01M 6/50 , H01M 10/42
--	--

H01M 50/284

with incorporated circuit boards, e.g. printed circuit boards [PCB]

Definition statement

This place covers:

Printed circuit boards [PCB] integrated within mountings, secondary casings, racks, modules or packs, suspension devices, shock absorbers, transport or carrying devices, or holders.

Special rules of classification

Printed circuit boards [PCB] combined with or integrated in interconnectors are classified in [H01M 50/519](#). This also encompasses the releasable fixing of PCB to an interconnector.

H01M 50/289

characterised by spacing elements or positioning means within frames, racks or packs (spacing elements inside cells other than separators, membranes or diaphragms [H01M 50/471](#))

References

Limiting references

This place does not cover:

Spacing elements inside cells other than separators, membranes or diaphragms	H01M 50/471
--	-----------------------------

Special rules of classification

Cooling plates that do not provide a spacing function are classified in [H01M 10/60](#) and subgroups.

Battery modules assembled by alternately stacking frames and batteries should be classified in [H01M 50/289](#) and in [H01M 50/204](#) and subgroups.

H01M 50/291

characterised by their shape

Definition statement

This place covers:

Illustrative example of spacing elements (140):

1.

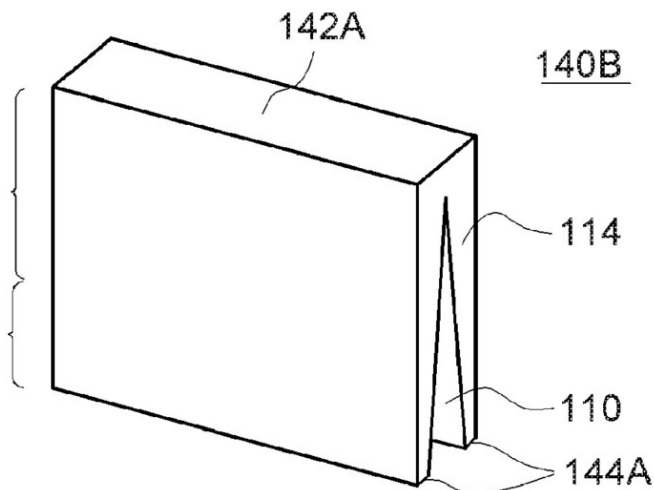
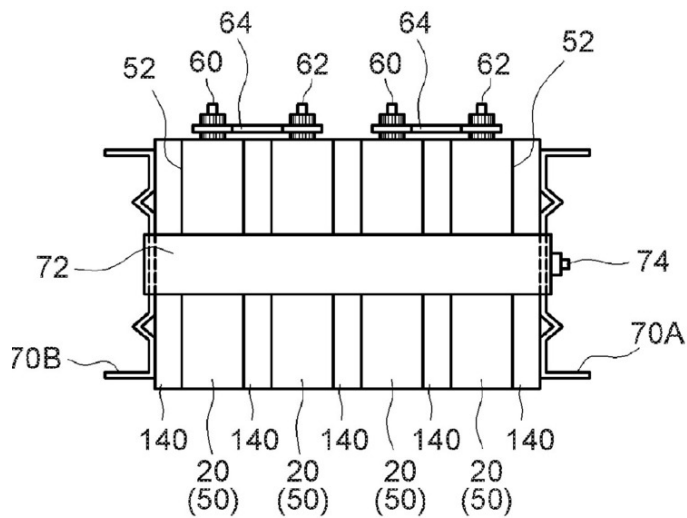

H01M 50/296

characterised by terminals of battery packs (terminals of batteries [H01M 50/543](#))

Definition statement

This place covers:

Terminals of secondary casings/battery packs.

References

Limiting references

This place does not cover:

Terminals of batteries	H01M 50/543
------------------------	-----------------------------

Special rules of classification

Terminals of secondary casing battery are classified in [H01M 50/296](#) only.

Terminals of primary casing battery or terminals formed by the primary casing itself, on the contrary, are classified in subgroups of [H01M 50/543](#).

Illustrative example for distinction between a terminal of primary casing battery and a terminal of a secondary casing battery:

1.

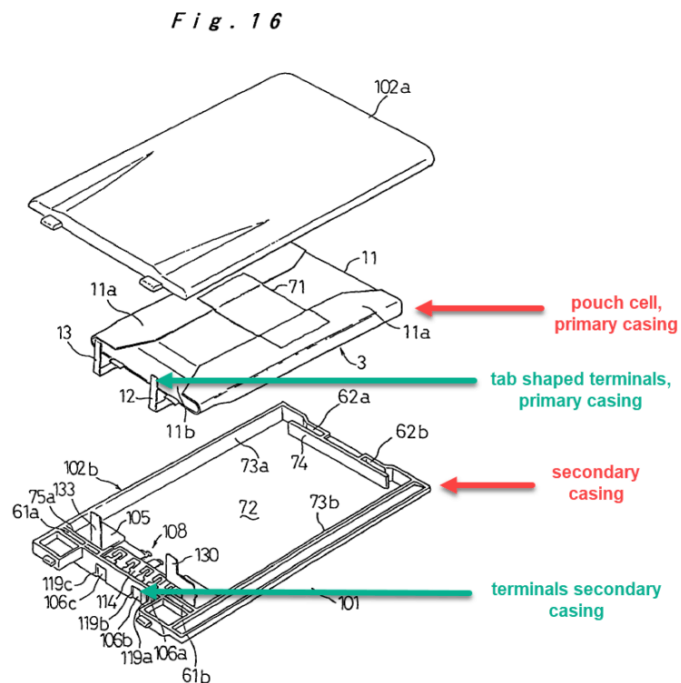

H01M 50/298

characterised by the wiring of battery packs

Definition statement

This place covers:

Illustrative example of wiring module (W) of batteries (12):

1.

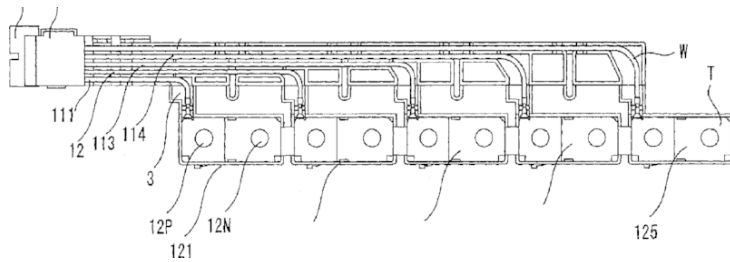

H01M 50/358

External gas exhaust passages located on the battery cover or case

Definition statement

This place covers:

Gas exhaust passages that are external to the cover/lid and located on the cover or case.

Illustrative example for an external gas exhaust passage on the lids:

1.

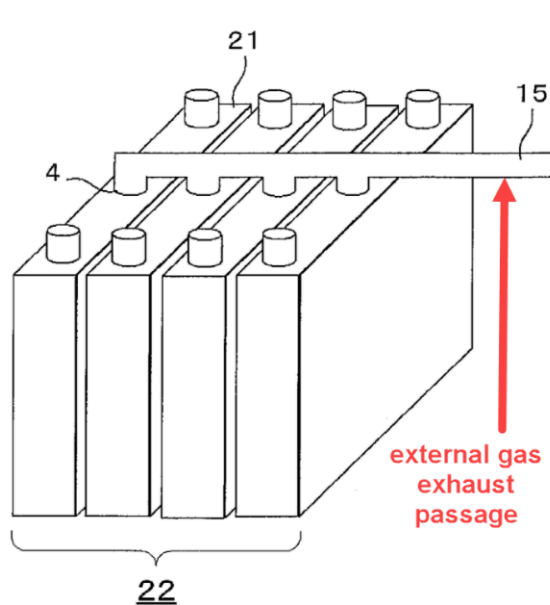

H01M 50/367

Internal gas exhaust passages forming part of the battery cover or case; Double cover vent systems

Definition statement

This place covers:

Gas exhaust passages that are internal, i.e. integrated within the cover, lid or casing.

Illustrative example for an internal gas exhaust passage (shown: double cover vent system 20):

1.

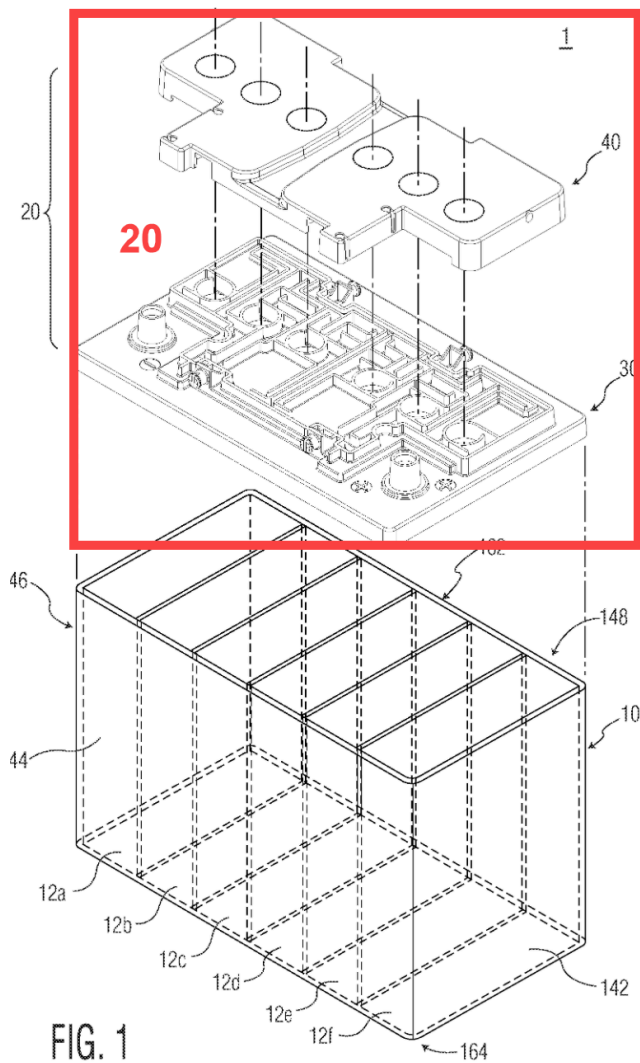

Definition statement

2.

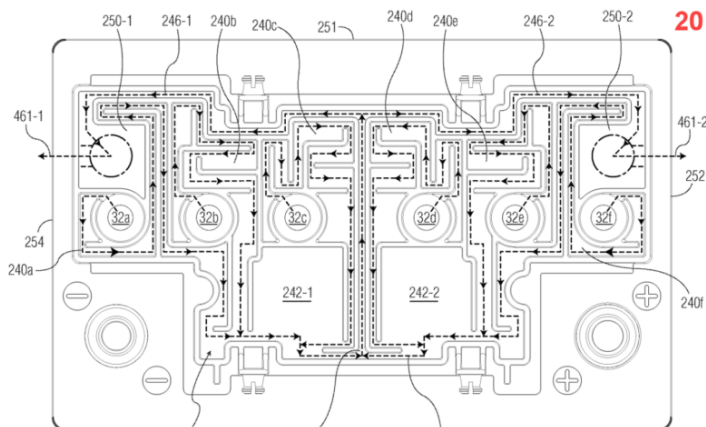

H01M 50/40

Separators; Membranes; Diaphragms; Spacing elements inside cells

Special rules of classification

Solid electrolytes acting as separators are classified in the application place, such as [H01M 10/056](#) or [H01M 12/08](#), and [H01M 50/40](#) and subgroups for the details concerning composition, structure or manufacturing processes.

H01M 50/451

comprising layers of only organic material and layers containing inorganic material

Definition statement

This place covers:

Separators comprising layers of only organic material and layers containing inorganic material.

Organic binders can be used in the inorganic layers to hold the inorganic materials together.

H01M 50/471

Spacing elements inside cells other than separators, membranes or diaphragms (for preventing incorrect contact inside or outside batteries [H01M 50/584](#)); Manufacturing processes thereof

Definition statement

This place covers:

Spacing elements.

Note:

Spacing elements are elements arranged within the primary casing but not between opposing electrochemically active electrodes.

Spacing elements differ from separators or diaphragms by virtue of their positioning inside the primary casing.

Illustrative example of spacer (glass wool 46 in head spacer: [H01M 50/474](#) and [H01M 50/483](#)):

1.

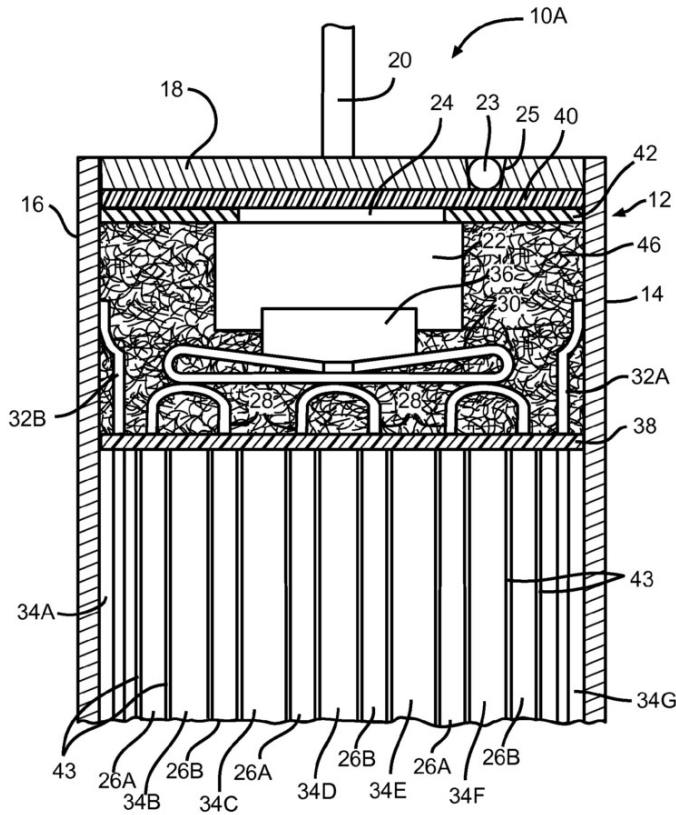

References

Limiting references

This place does not cover:

Spacing elements for preventing incorrect contact inside or outside batteries	H01M 50/584
---	-----------------------------

H01M 50/509

characterised by the type of connection, e.g. mixed connections

Definition statement

This place covers:

Illustrative example of series-parallel connections:

One portion 240 of a plate connects the negative terminals of a first group of cells together in parallel. Another portion 230 of the plate connects the positive terminals of a second group of cells together in parallel. Another portion 244 of the plate connects the groups of cells in series, forming the basis of a series-parallel group (when the opposite ends of the cells are similarly connected to additional plates).

1.

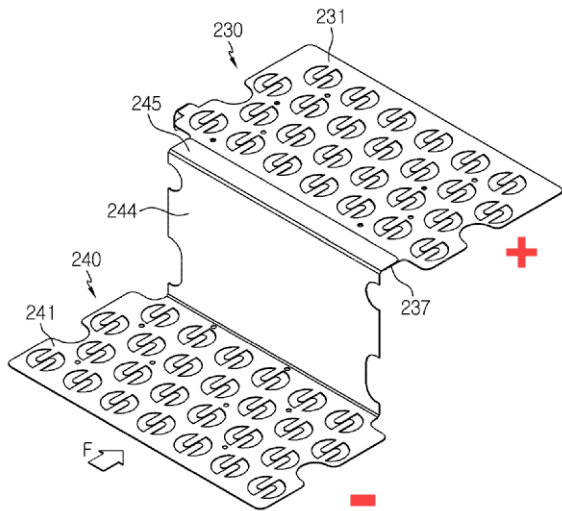

Illustrative example for interconnection only parallel ([H01M 50/512](#)):

2.

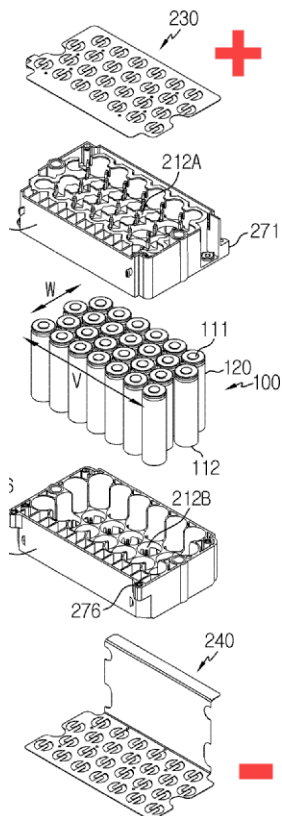

Synonyms and Keywords

In patent documents, the following words/expressions are often used as synonyms:

"series-parallel" and "mixed connections"

H01M 50/519

comprising printed circuit boards [PCB]

Definition statement

This place covers:

Interconnectors comprising printed circuit boards [PCB].

The PCB is located on or attached directly to the interconnector.

Illustrative examples for PCB fixed to an interconnector:

1.

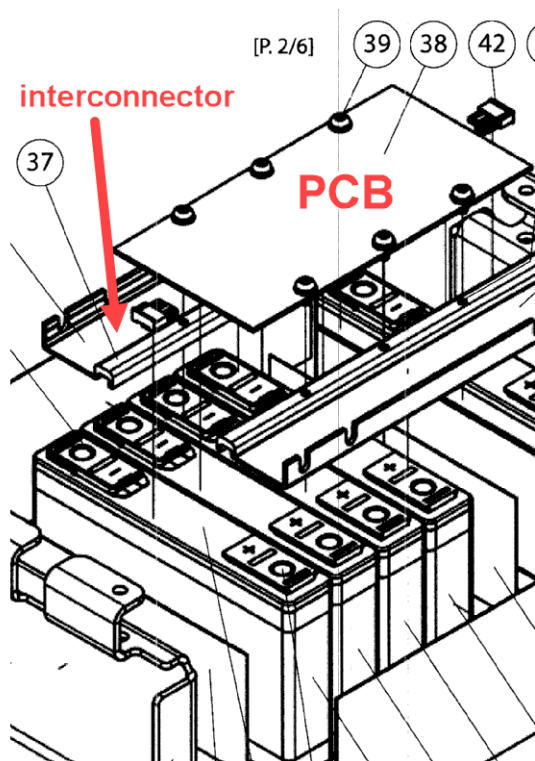

2.

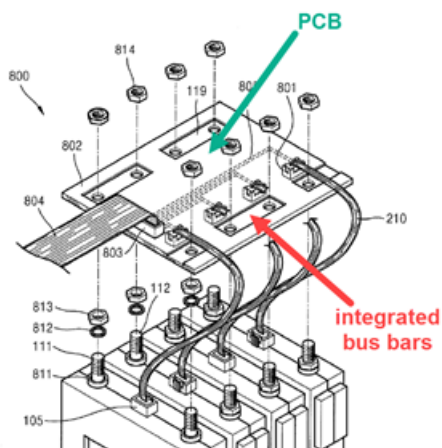

3.

Fig. 1

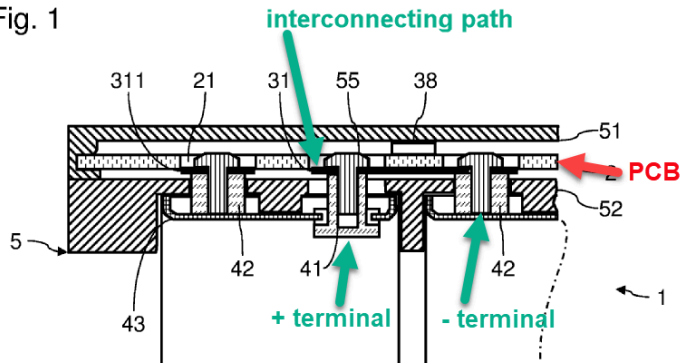

H01M 50/528

Fixed electrical connections, i.e. not intended for disconnection

Definition statement

This place covers:

Connections not intended for disconnection in the primary or secondary casing.

Illustrative example:

Connection members (30 and 33), which are not intended for disconnection, are welded to the primary casing battery terminal tabs (12 and 13, respectively) for connection to the protective circuit and the external terminals of the secondary casing battery:

1.

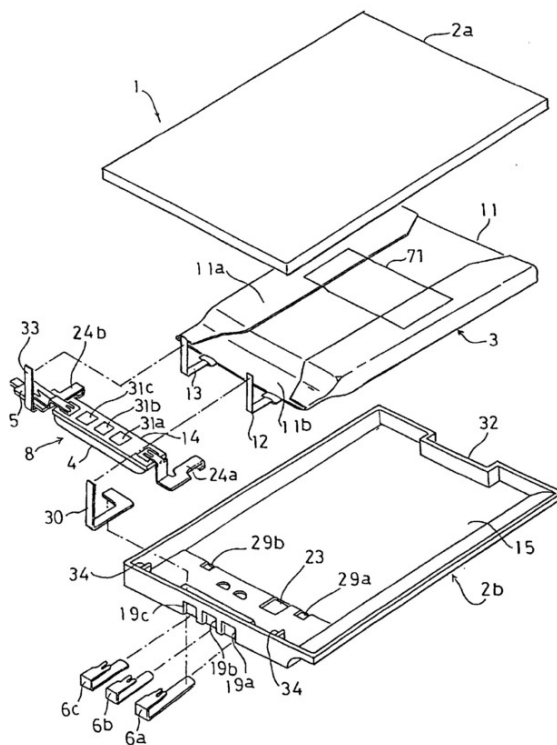

H01M 50/553

Terminals adapted for prismatic, pouch or rectangular cells

Definition statement

This place covers:

Terminals of primary casing batteries adapted to prismatic, pouch or rectangular cells.

Illustrative example for a pouch cell having both a window-shaped terminal ([H01M 50/555](#)) and a plate-shaped terminal ([H01M 50/557](#)):

1.

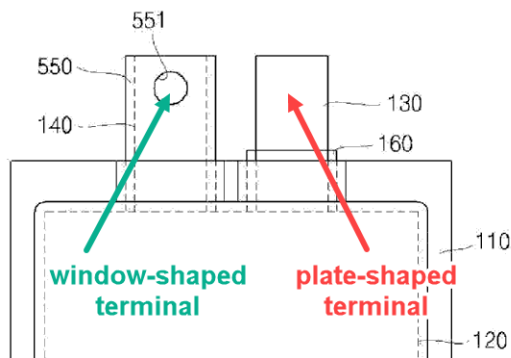

Illustrative example for a solid-state primary casing battery having two different terminals, namely a window-shaped terminal ([H01M 50/555](#)) and a knob-shaped terminal ([H01M 50/553](#)):

2.

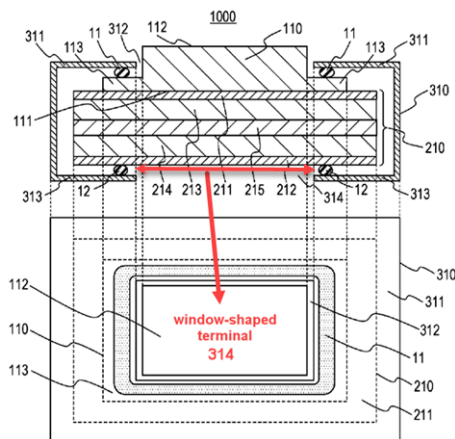

H01M 50/564

characterised by their manufacturing process

Definition statement

This place covers:

Processes of manufacturing terminals, including fixing the terminals of primary casing batteries to the lid, to the casing or to inner connectors.

Special rules of classification

If terminals are electrically connected to cell internal contacts during the process, then it is classified in [H01M 50/564](#) and [H01M 50/528](#).

H01M 50/566

by welding, soldering or brazing

Definition statement

This place covers:

Illustrative example for a fixing process by welding:

1.

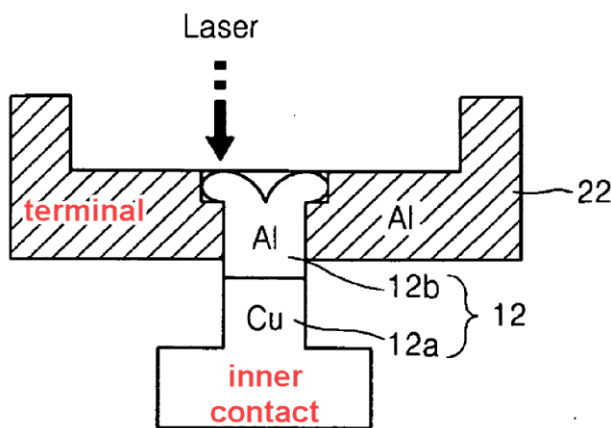

H01M 50/567

by fixing means, e.g. screws, rivets or bolts

Definition statement

This place covers:

Illustrative example for a fixing process by riveting:

1.

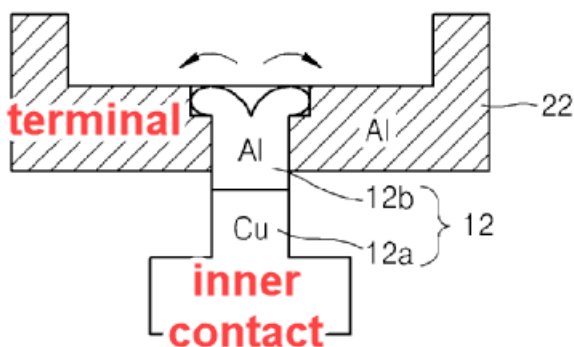

H01M 50/569

Constructional details of current conducting connections for detecting conditions inside cells or batteries, e.g. details of voltage sensing terminals (battery terminal connectors with integrated measuring arrangements [G01R 31/364](#))

Definition statement

This place covers:

Arrangements of current conducting connections for detecting conditions inside cells or batteries.

Illustrative example of the integration of a pressure sensitive detector inside a battery:

1.

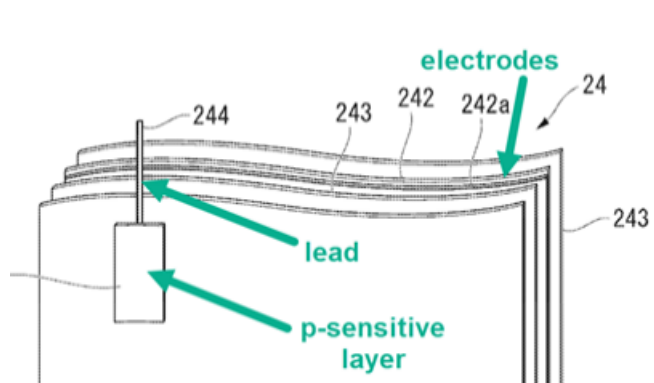

Illustrative example of an electrical connection probe specifically fixed to an interconnector for detecting voltage:

2.

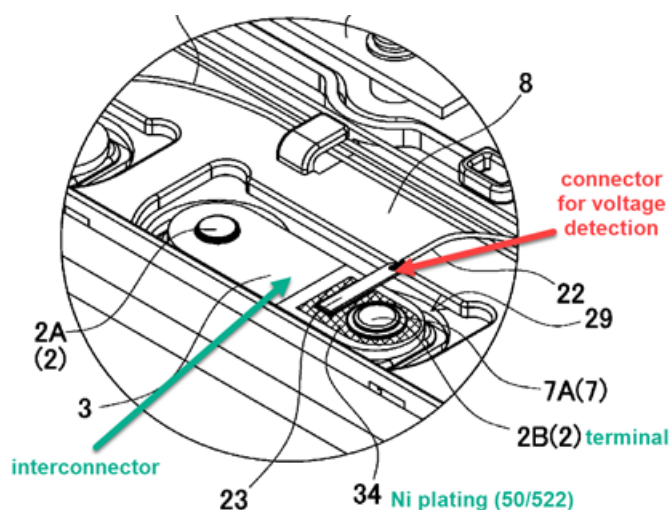

References

Limiting references

This place does not cover:

Battery terminal connectors with integrated measuring arrangements	G01R 31/364
--	-----------------------------

H01M 50/572

Means for preventing undesired use or discharge

Definition statement

This place covers:

Means for preventing incorrect electrical contact inside or outside a (primary or secondary) casing.

H01M 50/576

in response to theft

Definition statement

This place covers:

This encompasses aspects relating to the interruption of an established current connection and to aspects denying establishment of a current connection in the event of a (detected) theft or the absence of authorizing features (as a result of theft).

Illustrative example of a device requiring authorization by means of a key:

1.

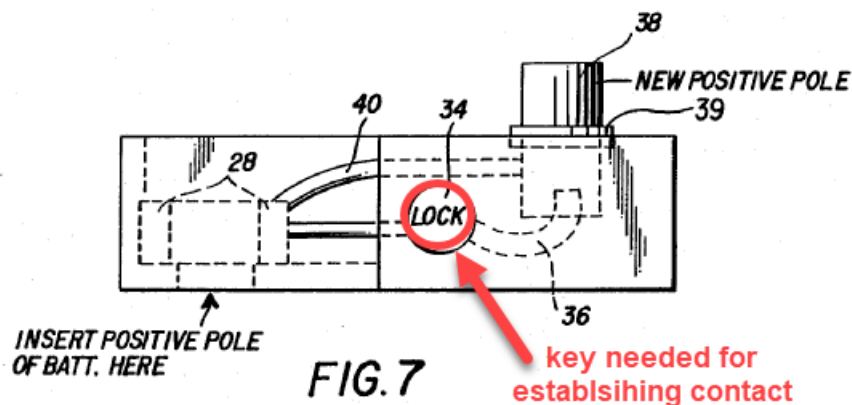

H01M 50/591

Covers

Definition statement

This place covers:

Covers for preventing incorrect or inadvertent electrical contact inside or outside a casing, e.g. for protecting terminals.

Illustrative example for a cover-like contact preventing means ([H01M 50/591](#)) being outside the casing ([H01M 50/588](#)):

1.

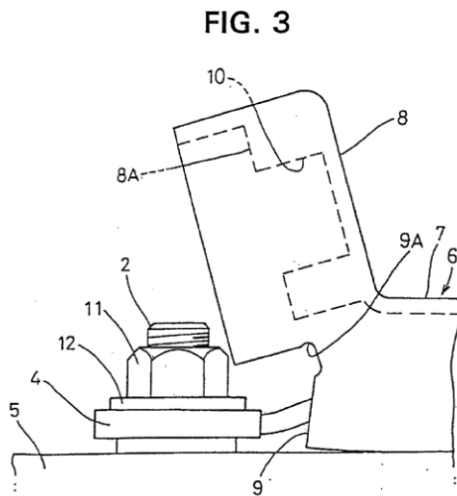

H01M 50/593

Spacers; Insulating plates

Definition statement

This place covers:

Spacers, insulating plates or barriers outside a primary or secondary casing for preventing incorrect or inadvertent electrical contact, e.g. short circuits between terminals.

Illustrative example for a spacer-like contact preventing means ([H01M 50/593](#)) being outside the casing ([H01M 50/588](#)):

1.

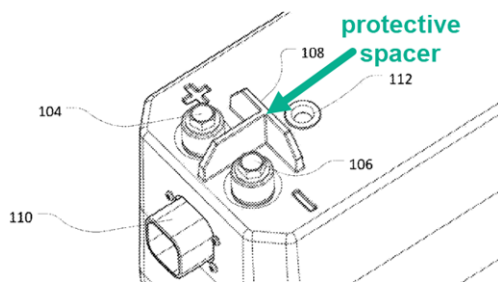

H01M 50/595

Tapes

Definition statement

This place covers:

Means for preventing incorrect electrical contact inside or outside a (primary or secondary) casing having the shape of a tape.

Illustrative example for a tape-like contact preventing means ([H01M 50/595](#)) being outside the casing ([H01M 50/588](#)):

1.

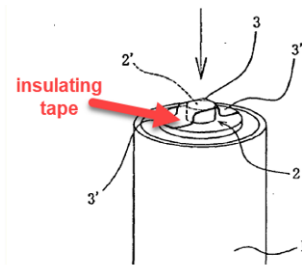

H01M 50/598

Guarantee labels

Definition statement

This place covers:

Means capable of indicating improper use of a battery.

As an example, submersion labels are cited, irreversibly changing their colour, for instance, when having had contact with liquid water or excessive humidity. The manufacturer can then challenge the guarantee due to proven improper use.

Labels, e.g. guarantee labels, may be visibly located at the outside of the housing or be hidden inside, to identify if the battery has been used.

Illustrative example for a guarantee label ([H01M 50/598](#)) being outside the casing ([H01M 50/588](#)):

1.

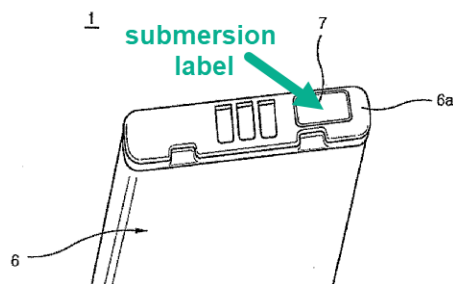

H01M 50/60

Arrangements or processes for filling or topping-up with liquids; Arrangements or processes for draining liquids from casings

Definition statement

This place covers:

Constructional details or processes for filling/topping-up with liquids or for draining liquids from casings.

Liquids may be an electrolyte, liquids for rinsing, liquids poured into casing in exceptional cases such as an emergency.

Illustrative example for a fire extinguishing liquid deliverable into casing by means of delivery conduits ([H01M 50/673](#)) for supplying electrolyte to a battery:

1.

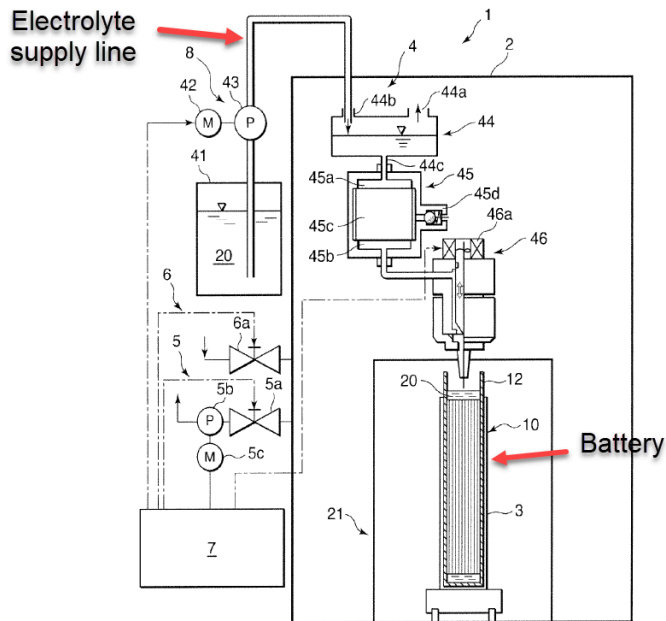

Illustrative example for a (fire extinguishing) liquid poured into casing from a container integrated in the lid of a battery casing ([H01M 50/682](#)):

2.

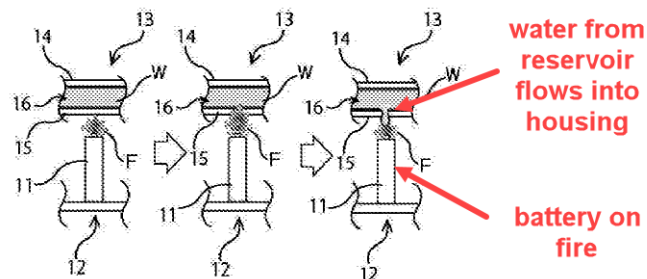

H01M 2250/402

Combination of fuel cell with other electric generators

References

Informative references

Attention is drawn to the following places, which may be of interest for search:

Combination of fuel cells with other electrochemical generators, e.g. capacitors, electrolyzers	H01M 16/003
---	-----------------------------