

## D02G

### CRIMPING OR CURLING FIBRES, FILAMENTS, THREADS, OR YARNS; YARNS OR THREADS

#### Definition statement

*This place covers:*

The post treatment of fibres and filaments (usually synthetic) to give them a structure more like natural fibres i.e. crimped or curled to make them easier to work with during further processing.

#### Relationships with other classification places

[D02G 3/00](#) covers the making of yarns or threads, e.g. fancy yarns; processes or apparatus for the production. [D02G](#) concerns treatments before this stage.

#### References

##### Limiting references

*This place does not cover:*

Yarns or threads, e.g. fancy yarns; Processes or apparatus for the production thereof	<a href="#">D02G 3/00</a>
Unwinding, paying-out, forwarding, winding or coiling filamentary material not intimately associated with spinning or twisting	<a href="#">B65H</a>
Cores, formers, supports or holders for coiled or wound material, e.g. bobbins	<a href="#">B65H</a>
Mechanical methods or apparatus in the manufacture of artificial filaments, threads, fibres, bristles, or ribbons	<a href="#">D01D</a>
Chemical features in the manufacture of artificial filaments, threads, fibres, bristles, or ribbons; apparatus specially adapted for the manufacture of carbon filaments	<a href="#">D01F</a>
Twisting oakum	<a href="#">D01G 35/00</a>
Spinning or twisting	<a href="#">D01H</a>
Making chenille	<a href="#">D03D</a> , <a href="#">D04D 3/00</a>
General aspects of chemical treatment	<a href="#">D06M</a>
Testing yarns, rovings, slivers, fibres, or fibre webs	<a href="#">G01</a>

#### Special rules of classification

The "common rule" applies in each of the subgroups

#### Glossary of terms

*In this place, the following terms or expressions are used with the meaning indicated:*

Fibre	a relatively-short, elongated member of natural or artificial material.
Filament	an endless or quasi-endless, elongated member of natural or artificial material.
Yarn	a unitary assembly of fibres, usually produced by spinning.
Thread	an assembly of yarns or filaments, usually produced by twisting.

False twisting	synthetic filaments are twisted, heat set while twisted and then untwisted to form a crimp
Texturing or texturizing	curling and crimping
Stuffer box	a confined space where yarns or filaments are compressed and deformed

## D02G 3/00

**Yarns or threads, e.g. fancy yarns; Processes or apparatus for the production thereof, not otherwise provided for (for producing crimped or curled yarns [D02G 1/00](#))**

### Definition statement

*This place covers:*

Yarns or threads characterised by the material or by the materials from which they are made. These aspects are covered by [D02G 3/02](#).

Yarns or threads characterised by constructional features. These aspects are covered by [D02G 3/22](#).

Yarns or threads characterised by the purpose for which they are designed. These aspects are covered by [D02G 3/44](#).

### References

#### Limiting references

*This place does not cover:*

Shoe laces	<a href="#">A43C 1/00</a>
Dental floss	<a href="#">A61C 15/04</a>
Warp knitted yarns	<a href="#">D04B 21/202</a>
Braided cords, lines or tows	<a href="#">D04C 1/12</a>
Ropes and strands for ropes	<a href="#">D07B</a>

#### Informative references

*Attention is drawn to the following places, which may be of interest for search:*

Wearing apparel	<a href="#">A41B - A41G</a>
Selection of special materials for outerwear	<a href="#">A41D 31/00</a>
Woven materials characterised by the material or construction of the yarn	<a href="#">D03D 15/00</a>
Weft knitting processes characterised primarily by the use of particular thread materials	<a href="#">D04B 1/14</a>
Warp knitting processes characterised by the incorporation by knitting, in one or more thread, fleece, or fabric layers, of reinforcing, binding, or decorative threads	<a href="#">D04B 21/14</a>

### Special rules of classification

In this main group, further classification in indexing scheme [D10B](#) for aspects relating to yarns is required.

## D02G 3/02

**Yarns or threads characterised by the material or by the materials from which they are made**

### Special rules of classification

The classification is desirably complemented by a classification in the indexing scheme [D10B 2101/00](#) - [D10B 2331/301](#) for identifying the thread composition.

## D02G 3/045

**{all components being made from artificial or synthetic material}**

### Definition statement

*This place covers:*

Blended or other yarns or threads containing components including aramid fibres and similar high performance fibres.

### Synonyms and Keywords

*In patent documents, the following words/expressions are often used with the meaning indicated:*

"Aromatic polyamide"	"aramid".
"Para aramid"	"terephthalamide (PPTA)".
"Meta aramid"	"poly-metaphenylene isophthalamide (MPIA)".
"Ultra high molecular weight polyethylene (UHMWPE)"	"poly(p-phenylene-2,6-benzobisoxazole".

## D02G 3/08

**Paper yarns or threads**

### References

#### Informative references

*Attention is drawn to the following places, which may be of interest for search:*

Woven fabrics characterised by using paper threads	<a href="#">D03D 15/65</a>
--	----------------------------

## D02G 3/12

**Threads containing metallic filaments or strips**

### References

#### Informative references

*Attention is drawn to the following places, which may be of interest for search:*

Gloves made of wire-mesh	<a href="#">A41D 19/01511</a>
Resistance heating devices in seats specially adapted for vehicles	<a href="#">B60N 2/5685</a>
Woven fabrics characterised by the warp or weft elements being of stiff material, e.g. wire	<a href="#">D03D 15/593</a>

## D02G 3/16

### Yarns or threads made from mineral substances

#### References

##### *Informative references*

Attention is drawn to the following places, which may be of interest for search:

Artificial filaments or the like of other substances, manufacture thereof, apparatus specially adapted for the manufacture of carbon filaments	<a href="#">D01F 9/00</a>
Woven fabrics characterised by using threads comprising a mineral	<a href="#">D03D 15/242</a>

#### Special rules of classification

The classification is desirably complemented by a classification in the Indexing Codes [D10B 2101/00](#) - [D10B 2101/16](#) for identifying the thread composition.

## D02G 3/18

### from glass or the like

#### References

##### *Informative references*

Attention is drawn to the following places, which may be of interest for search:

Fibreglass strands extruded from spinnerets	<a href="#">B65H 2701/3122</a>
Glass fibre or filament	<a href="#">C03C 13/00</a>
Woven fabrics using glass fibres	<a href="#">D03D 15/267</a>

## D02G 3/28

Doubled, plied, or cabled threads {([D02G 3/32](#), [D02G 3/36](#) take precedence; effect yarns [D02G 3/34](#); details of spindles, e.g. bearings [D01H 7/86](#))}

#### Definition statement

This place covers:

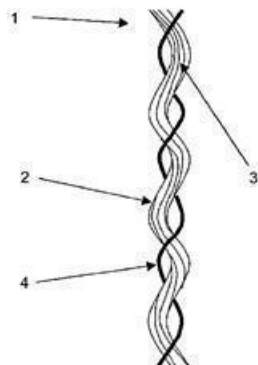

US-A-2004/0065072

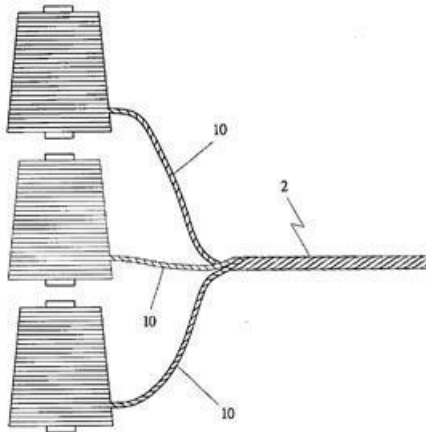

US-A-2005/0009430

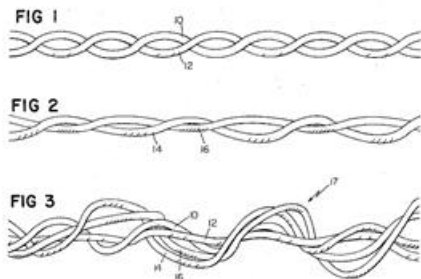

US-A-3 690 056

### Glossary of terms

*In this place, the following terms or expressions are used with the meaning indicated:*

Doubled yarns	yarns consisting of two or more strands treated as one in the weaving process. The strands are not twisted together. The doubled yarn must not be confused with ply yarns, which are stronger because they are twisted.
Plied or folded yarns	yarns comprising two or more strands or yarns twisted together. They are termed two-ply, three-ply, and so on, according to the number used in their construction. Ply yarns are preferred where durability is all-important.
Cabled or cord yarns	yarns comprising two or more plied yarns twisted together. In general they are constructed by twisting the plied yarns around each other successively in the opposite direction of the preceding twist, i.e. S/Z/S or Z/S/Z. As a result, the opposite twist directions cause the plies to grip each other and maintain adherence. These yarns are hard, rough and strong.

### D02G 3/281

{using one drawing frame for two slivers and twisting of the slivers to a single yarn, i.e. spin-twisting (guides having associated actuators with mutual action [D01H 13/1658](#))}

#### Definition statement

*This place covers:*

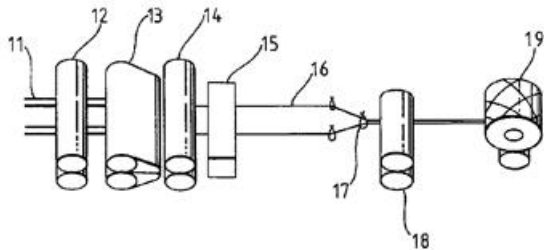

EP-A-0 038 143

### D02G 3/283

{using hollow spindles through which one yarn is running}

#### Definition statement

*This place covers:*

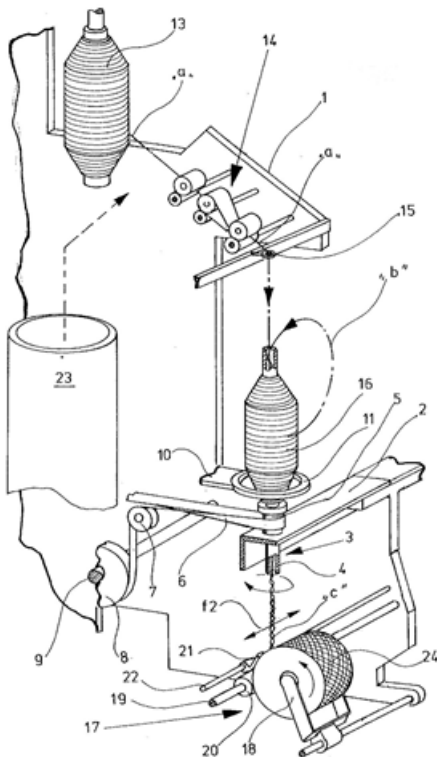

EP-A-0 593 919

## References

### Informative references

Attention is drawn to the following places, which may be of interest for search:

Multiple twist arrangements	<a href="#">D01H 7/86</a>
-----------------------------	---------------------------

## D02G 3/285

{one yarn running over the feeding spool of another yarn}

### Definition statement

This place covers:

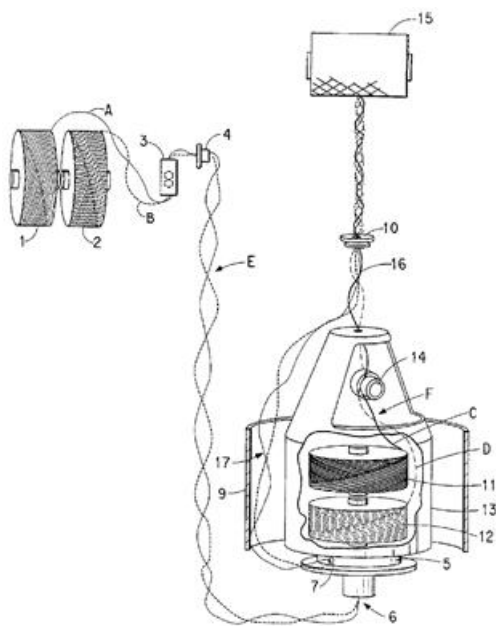

US-A-6 098 392

## References

### Informative references

Attention is drawn to the following places, which may be of interest for search:

Spinning or twisting machines for imparting multiple twist, e.g. two-for-one twisting	<a href="#">D01H 1/10</a>
Multiple twist arrangements	<a href="#">D01H 7/86</a>

**D02G 3/286**

{with alternatively "S" and "Z" direction of twist, e.g. Self-twist process}

**Definition statement**

*This place covers:*

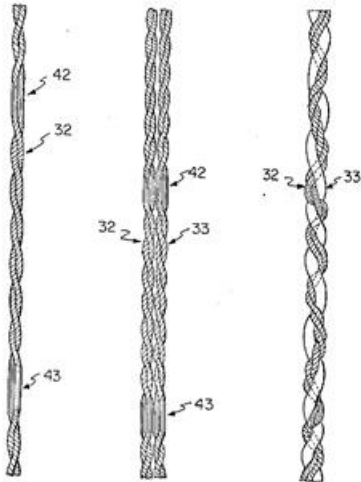

US-A-4 246 750

**Glossary of terms**

*In this place, the following terms or expressions are used with the meaning indicated:*

Self-twist yarn	yarn that comprises two or more strands that have areas of twist in what is known as the Z-direction and areas of twist in what is known as the S-direction. The twisted areas in the strands are each separated by non-twisted areas. Torque is trapped in the twisted strand and is otherwise known as residual twist. When two or more twisted strands are brought together, the torque or residual twist causes the strands to twist around each other naturally, without interference, to form a self twisted yarn.
-----------------	--

**D02G 3/288**

{with same direction of twist, but with an amount of twist varying along the thread}

**Definition statement**

*This place covers:*

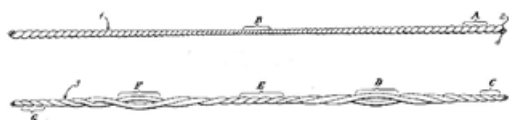

US-A-2 961 010



**D02G 3/30****Crêped or other highly-twisted yarns or threads****Glossary of terms**

*In this place, the following terms or expressions are used with the meaning indicated:*

Crêped yarns or hard twist	yarns with a number of twist per unit of length higher than ordinary yarn.
----------------------------	--

**D02G 3/32****Elastic yarns or threads {; Production of plied or cored yarns, one of which is elastic}****References****Informative references**

*Attention is drawn to the following places, which may be of interest for search:*

Woven fabrics using stretchable or elastic threads	<a href="#">D03D 15/56</a>
Abrics or articles defined by weft knitting using elastic threads	<a href="#">D04B 1/18</a>
Fabrics or articles defined by warp knitting incorporating elastic threads	<a href="#">D04B 21/18</a>

**D02G 3/322**

**{using hollow spindles (details of spindles, e.g. bearings [D01H 7/86](#))}**

**Definition statement**

*This place covers:*

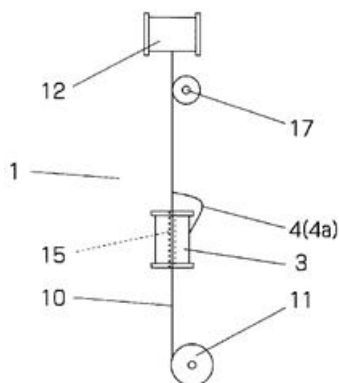

WO-A-2010/064647

## D02G 3/324

{using a drawing frame}

### Definition statement

*This place covers:*

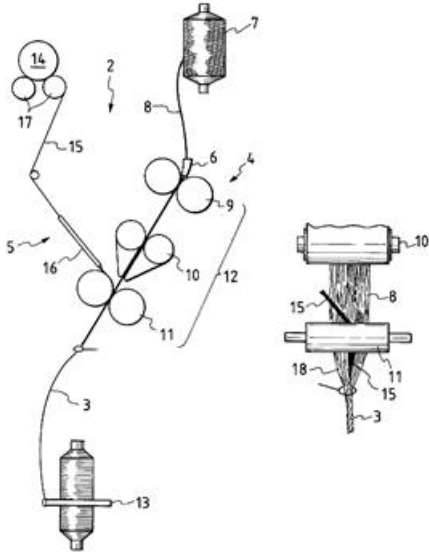

EP-A-0 548 474

## D02G 3/34

Yarns or threads having slubs, knobs, spirals, loops, tufts, or other irregular or decorative effects, i.e. effect yarns {(carding machines for producing decorative or fancy effects in products [D01G](#); drafting machines with varying draft according to a pre-arranged pattern [D01H 5/36](#))}

### Definition statement

*This place covers:*

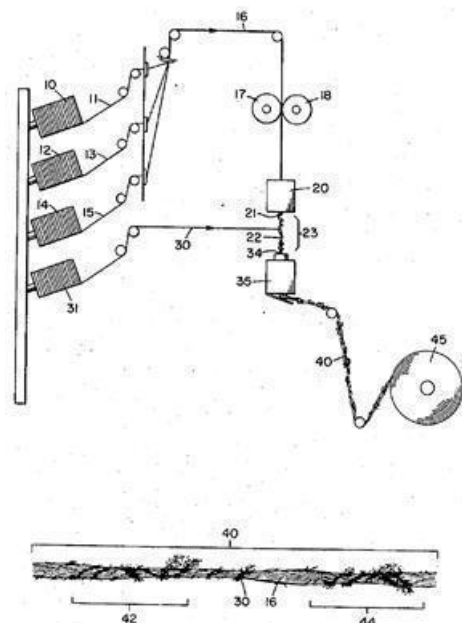

US-A-4 304 092

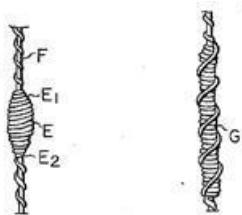

FR-A-2 315 554

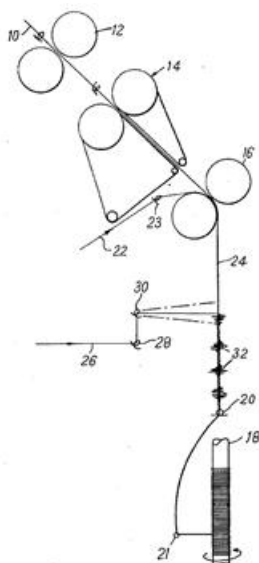

US-A-3 945 189

**References**

**Limiting references**

*This place does not cover:*

Filamentary material with threaded or stringed pearls or beads	<a href="#">D04D 1/04</a>
--	---------------------------

**D02G 3/346**

**{with coloured effects, i.e. by differential dyeing process}**

**References**

**Informative references**

*Attention is drawn to the following places, which may be of interest for search:*

Woven fabrics characterised by using coloured threads	<a href="#">D03D 15/54</a>
Passing of textile materials through liquids, gases or vapours to effect treatment of yarns, threads or filaments	<a href="#">D06B 3/04</a>

## D02G 3/36

Cored or coated yarns or threads ([D02G 3/34](#), [D02G 3/40](#) take precedence); elastic yarns or threads [D02G 3/32](#))

### Definition statement

*This place covers:*

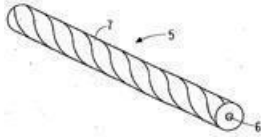

WO-A-01/98572

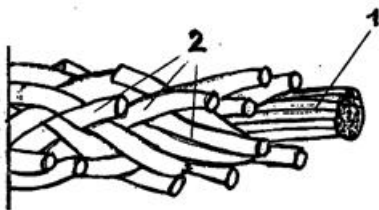

DE-U-202006008644

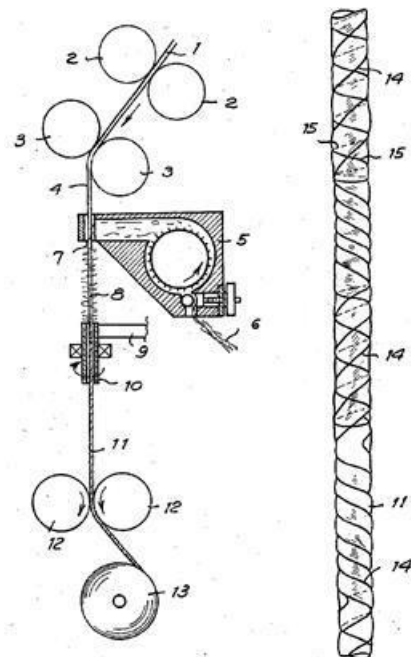

US-A-4 056 924

### References

#### Limiting references

*This place does not cover:*

Cored yarns or threads with an elastic core and/or sheath	<a href="#">D02G 3/32</a>
---	---------------------------

**D02G 3/365**

{around which a reel supporting feeding spool rotates}

**Definition statement**

*This place covers:*

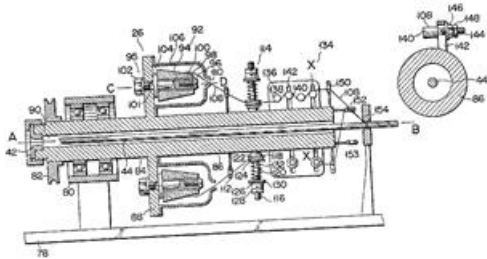

CH-A-607 246

**D02G 3/38**

Threads in which fibres, filaments, or yarns are wound with other yarns or filaments, {e.g. wrap yarns, i.e. strands of filaments or staple fibres are wrapped by a helically wound binder yarn; ([D02G 3/32](#) takes precedence)}; (covering endless core threads with fibres by using open-end spinning techniques [D01H 4/00](#))

**Definition statement**

*This place covers:*

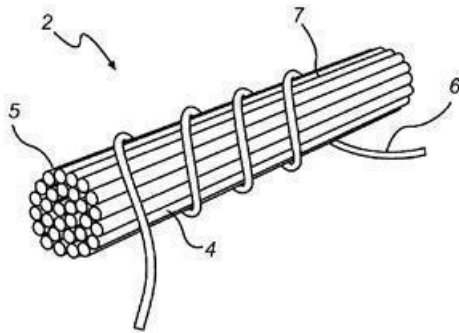

WO-A-2009037631

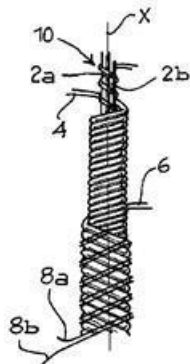

EP-A-1 964 952

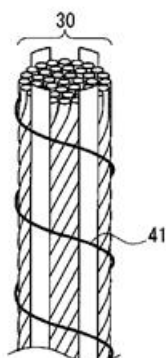

WO-A-2009/131149

## D02G 3/40

**Yarns in which fibres are united by adhesives; Impregnated yarns or threads**

### References

#### Informative references

Attention is drawn to the following places, which may be of interest for search:

Passing of yarns, threads or filaments through liquids, gases or vapours to effect treatment	<a href="#">D06B 3/04</a>
--	---------------------------

## D02G 3/404

**{Yarns or threads coated with polymeric solutions}**

### References

#### Informative references

Attention is drawn to the following places, which may be of interest for search:

Modifying the surface of filaments, yarns or threads by treating with particulate, semi-solid, or solid substances	<a href="#">D02J 3/18</a>
--	---------------------------

## D02G 3/406

**{where the polymeric solution is removable at a later stage, e.g. by washing}**

### Definition statement

*This place covers:*

Yarns or threads coated with polymeric solutions removable at a later stage. The polymeric solution can also be in the form of a yarn, e.g. twisted or blended with other components of the yarn.

## References

### Informative references

Attention is drawn to the following places, which may be of interest for search:

Woven fabrics using scaffolding threads, i.e. threads removed after weaving	<a href="#">D03D 15/68</a>
---	----------------------------

## D02G 3/42

### Chenille threads

### Definition statement

This place covers:

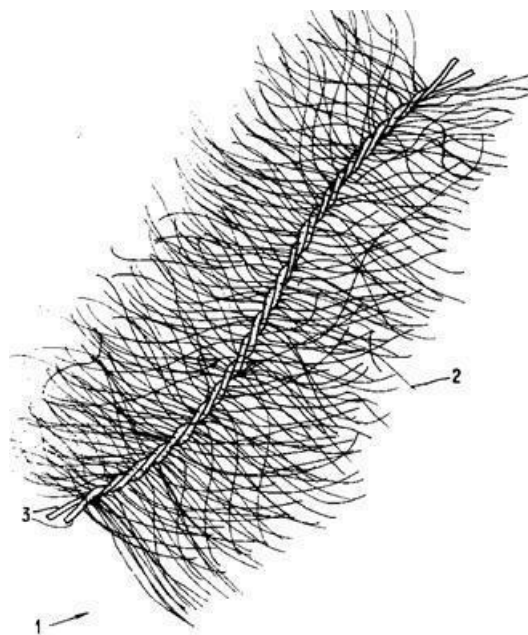

EP-A-0 620 185

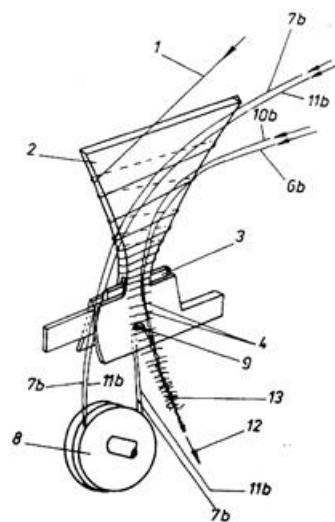

DE 3 445 138

## References

### Informative references

Attention is drawn to the following places, which may be of interest for search:

Chenille fabrics	<a href="#">D03D 27/18</a>
Chenille trimmings	<a href="#">D04D 3/00</a>

## Glossary of terms

In this place, the following terms or expressions are used with the meaning indicated:

Chenille yarn	is manufactured by placing short lengths of yarn, called the "pile", between two core yarns and then twisting the yarn together. The edges of these piles then stand at right angles from the yarn's core, giving the chenille both its softness and its characteristic look. Chenille will look different in one direction compared to another, as the fibres catch the light differently.
---------------	---

## D02G 3/44

Yarns or threads characterised by the purpose for which they are designed {(protective gloves [A41D 19/00](#); protective clothing [A62B 17/00](#); ropes [D07B 1/02](#)}

## References

### Informative references

Attention is drawn to the following places, which may be of interest for search:

Professional, industrial or sporting protective garments	<a href="#">A41D 13/00</a>
Selection of special materials for outerwear	<a href="#">A41D 31/00</a>
Woven fabrics characterised by the material of the yarn	<a href="#">D03D 15/00</a>
Fabrics or articles defined by weft knitting characterised by the thread material	<a href="#">D04B 1/14</a>
Fabrics or articles defined by warp knitting characterised by the thread material	<a href="#">D04B 21/14</a>

## D02G 3/441

{Yarns or threads with antistatic, conductive or radiation-shielding properties (electroconductive, anti-static or radiation-shielding filaments [D01F 1/09](#), [D01F 1/106](#); anti-static fabrics [D03D 15/533](#); conducting, insulating or anti-static layers for floor coverings [D06N 7/0042](#)}

## References

### Informative references

Attention is drawn to the following places, which may be of interest for search:

Threads containing metallic filaments or strips	<a href="#">D02G 3/12</a>
Special materials for outerwear against electric shocks or static electricity	<a href="#">A41D 31/26</a>



Car seat heating	<a href="#">B60N 2/5678</a>
Antistatic fabrics	<a href="#">D03D 15/533</a>
Flexible ohmic-resistance heating	<a href="#">H05B 3/34</a>
Electromagnetic shielding materials comprising electro-conductive fibres	<a href="#">H05K 9/009</a>

## D02G 3/442

{Cut or abrasion resistant yarns or threads}

### References

#### Informative references

Attention is drawn to the following places, which may be of interest for search:

Protective gloves resistant to mechanical aggressions, e.g. cutting, piercing	<a href="#">A41D 19/01505</a>
Special materials for outerwear resistant to mechanical aggressions, e.g. pierceproof materials	<a href="#">A41D 31/24</a>

## D02G 3/443

{Heat-resistant, fireproof or flame-retardant yarns or threads (fire- or flame-proof filaments [D01F 1/07](#); woven fabrics using heat-resistant or fireproof threads [D03D 15/513](#))}

### References

#### Informative references

Attention is drawn to the following places, which may be of interest for search:

Protective gloves with fire protection	<a href="#">A41D 19/01529</a>
Special materials for outerwear against fire and heat	<a href="#">A41D 31/08</a>
Fire resistant clothes	<a href="#">A62B 17/003</a>
Woven fabrics using heat-resistant or fireproof threads	<a href="#">D03D 15/513</a>

## D02G 3/444

{Yarns or threads for use in sports applications (strings for tennis rackets [A63B 51/02](#))}

### Definition statement

This place covers:

Yarns or threads for sport applications, including fishing lines and tennis racket strings made up of yarns.

## References

### Informative references

Attention is drawn to the following places, which may be of interest for search:

Fishing lines	<a href="#">A01K 91/00</a>
Strings for tennis rackets	<a href="#">A63B 51/02</a>

## D02G 3/445

{Yarns or threads for use in floor fabrics (floor fabrics [A47G 27/00](#); floor coverings on textile basis [D06N 7/0005](#))}

### Definition statement

This place covers:

Yarns or threads for use in floor fabrics, e.g. carpets, floor mats, artificial lawn.

## References

### Informative references

Attention is drawn to the following places, which may be of interest for search:

Woven carpets	<a href="#">D03D 27/00</a>
Tufted carpets	<a href="#">D05C 17/02</a>
Artificial grass	<a href="#">E01C 13/08</a>

## D02G 3/447

{Yarns or threads for specific use in general industrial applications, e.g. as filters or reinforcement}

## References

### Informative references

Attention is drawn to the following places, which may be of interest for search:

Screen cloths and wire cloths in papermaking machines	<a href="#">D21F 1/0027</a> , <a href="#">D21F 1/10</a>
Extile reinforcements in driving belts	<a href="#">F16G 1/10</a>
Textile reinforcement in V-belts	<a href="#">F16G 5/06</a>
Packing materials shaped as strands, ropes, threads, ribbons or the like	<a href="#">F16J 15/22</a>

**D02G 3/449**

{Yarns or threads with antibacterial properties (filaments containing agents inhibiting growth of microorganisms [D01F 1/103](#))}

**References****Informative references**

Attention is drawn to the following places, which may be of interest for search:

Special materials for outerwear with antibacterial or antimicrobial materials	<a href="#">A41D 31/30</a>
Filaments containing agents inhibiting growth of microorganisms	<a href="#">D01F 1/103</a>

**D02G 3/48**

Tyre cords {(tyre reinforcements [B60C 9/00](#); metal cords for reinforcing rubber or plastic articles [D07B 1/0606](#))}

**Definition statement**

*This place covers:*

Textile tyre cords and hybrid tyre cords.

**References****Limiting references**

*This place does not cover:*

Metal tyre cords	<a href="#">D07B 1/0606</a>
------------------	-----------------------------

**Informative references**

Attention is drawn to the following places, which may be of interest for search:

Reinforcements or ply arrangement of pneumatic tyres	<a href="#">B60C 9/00</a>
Driving belts made of fibrous material, e.g. textiles, whether rubber-covered or not	<a href="#">F16G 1/10</a> , <a href="#">F16G 1/28</a>
V-belts made of rubber with textile reinforcement	<a href="#">F16G 5/08</a>

**Special rules of classification**

Hybrid cords (i.e. comprising metal wires and filaments or yarns within the same rope or strand) have to be classified in both [D02G 3/48](#) and [D07B 1/0606](#) or lower hierarchy.