

## B23D

**PLANING; SLOTTING; SHEARING; BROACHING; SAWING; FILING; SCRAPING; LIKE OPERATIONS FOR WORKING METAL BY REMOVING MATERIAL, NOT OTHERWISE PROVIDED FOR (making toothed gears or the like [B23F](#); cutting metal by applying heat locally [B23K](#); arrangements for copying or controlling [B23Q](#))**

### Definition statement

*This place covers:*

Planing, slotting, shearing, broaching, sawing, filing, scraping like operations for working metal by removing metal not otherwise provided for..

### Relationships with other classification places

In general, although displaying sometimes a structure which can appear similar, devices which are suitable for shearing metal sheets or metal plates in the range of gauges used in industry for product manufacture are not suitable for cutting paper, plastics, fabrics etc., mainly because of blades shapes and settings. Devices for cutting paper, plastics or fabrics are mainly classified in [B26D](#) and [B26F](#). It is observed that cutting with abrasive disks is seen as sawing, see e.g. [B23D 45/00](#) - [B23D 65/04](#), [B27B](#), [B28D](#).

### References

#### Limiting references

*This place does not cover:*

Surgical saws	<a href="#">A61B 17/14</a>
Sawing wood or similar material	<a href="#">B27B</a>

#### Informative references

*Attention is drawn to the following places, which may be of interest for search:*

Punching, perforating, making articles by processing sheet metal, tubes or profiles	<a href="#">B21D</a>
Grinding	<a href="#">B24</a>
Working rails in situ by planing	<a href="#">E01B 31/15</a>

### Glossary of terms

*In this place, the following terms or expressions are used with the meaning indicated:*

Planing	Also called "shaping" this process relates to the removal of material in the form of chips by a relative movement of at least one tool with a geometrically defined cutting edge relative to a workpiece along a non-circular trajectory. Both the tool and the workpiece are non-rotating. The process is similar to turning ( <a href="#">B23B</a> ) except that in turning either the tool is moved around the workpiece in a circular path or the workpiece is rotated. In turning the tool path is therefore circular with respect to the workpiece whereas in planing the toolpath is non-helical.
---------	--

Slotting	The production of a slot by a process similar to planing, i.e. the removal of material in the form of chips by a relative movement of at least one tool with a geometrically defined cutting edge relative to a workpiece along a non-circular trajectory.
Shearing	To fracture material through the application of a load transverse to the material surface(s) on which the load is applied.
Broaching	Method of machining by chip removal employing a multi-toothed cutting tool in which the functional edges of the tool teeth are so related to one another that the tip of one tooth extends further than that of an adjacent tooth from a datum line interior to the tool extending parallel to the path of relative movement between tool and work and in whose operation the teeth successively engage the work, each tooth or set of teeth removing an amount of material determined by its relationship to the adjacent tooth.
Filing	Removal of material in the form of chips by a tool having multiple geometrically defined cutting edges arranged at similar distances from a datum line interior to the tool extending parallel to the path of relative movement between tool and work in order to produce a surface of predetermined form.
Rasping	Filing with a course file with multiple geometrically defined raised teeth usually formed in a sheet of metal by deformation of the sheet
Sawing	The division of a workpiece into two or more parts using a tool with a toothed, grinding or friction edge by removing material in the form of chips, dust or molten material.
Scraping	Removal of material by a tool, generally a hand tool, comprising a geometrically defined cutting edge, used primarily to alter surface characteristics of the workpiece, rather than change the geometry. Examples include deburring by scraping (i.e. removal of sharp corners) and "roughening" of ground machine tool slideways to provide oil pockets.
Like operations	Operations which remove metal through a geometrically defined cutting edge but for which no other provision exists within the entire classification scheme.

## **B23D 1/00**

### **Planing or slotting machines cutting by relative movement of the tool and workpiece in a horizontal straight line only**

#### **Definition statement**

*This place covers:*

Machines and devices for planing or slotting cutting by relative movement of the tool and workpiece in a horizontal straight line only during the machining pass . The tool or workpiece may be fed in a non-linear manner between passes to produce profiled stock.

Planing/shaping machines are generally (but not necessarily) large and typically used to produce elongate products such as rails or machine tool slideways.

FIG. 6

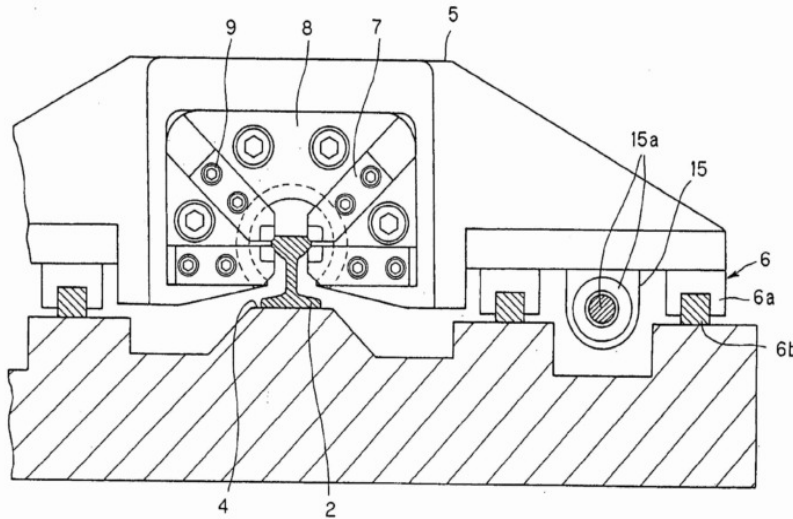

Patent Application Publication Feb. 24, 2005 Sheet 6 of 15 US 2005/0042054 A1

rail planing machine classed in [B23D 1/006](#)

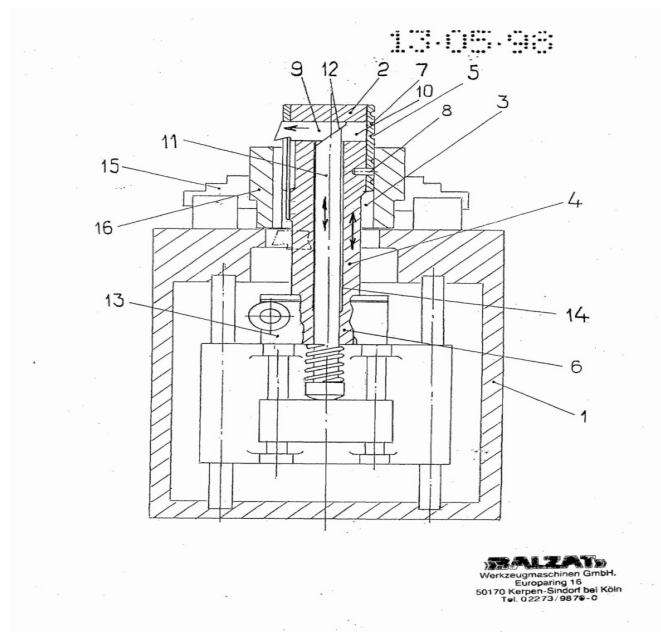

slotting machine classed in [B23D 3/02](#)

### Relationships with other classification places

Both of the terms "planing" and "slotting" relate to the removal of material in the form of chips by a relative movement of at least one tool with a geometrically defined cutting edge and the workpiece along a non-circular trajectory. Both the tool and the workpiece are non-rotating. The process is similar to turning ([B23B](#)) except that in turning either the tool is moved around the workpiece in a circular path

## Relationships with other classification places

or the workpiece is rotated. In turning the tool path is therefore circular with respect to the workpiece whereas in planing or slotting the toolpath is non-helical.

Tools which can be used for both planing/slotting and for turning with distinctive constructional features are classed in [B23B](#) according to the functional feature. This is especially true for tool holders with replaceable indexable inserts.

## References

### Limiting references

*This place does not cover:*

Milling slots	<a href="#">B23C 3/28</a>
Making gears or the like by planing or slotting	<a href="#">B23F</a>
Multi stage processes involving planing/slotting and also other operations classed in <a href="#">B23B</a> , <a href="#">B23C</a> , <a href="#">B23F</a> , making particular items.	<a href="#">B23P 13/00</a> , <a href="#">B23P 15/00</a> , <a href="#">B23P 23/00</a>
Details of machine tools and accessories not related to the operation being performed including:	<a href="#">B23Q</a>
- tool changing	<a href="#">B23Q 3/155</a>
- conveying workpiece into and from machine	<a href="#">B23Q 7/00</a>
- evacuation of swarf,	<a href="#">B23Q 11/0042</a>
- guarding & protective coverings	<a href="#">B23Q 11/08</a>
Adaptive control and/or computer controls for planing or slotting processes	<a href="#">B23Q 15/00</a> , <a href="#">G05B 15/02</a>
- measuring or sensing	<a href="#">B23Q 17/00</a>
Planing of wood	<a href="#">B27C 1/00</a>
Hand planes for wood	<a href="#">B27G 17/00</a>

### Informative references

*Attention is drawn to the following places, which may be of interest for search:*

Details of turning tools which may also be usable as planing or slotting tools	<a href="#">B23B 27/00</a>
Details of turning tool holders which may also be usable as planing or slotting tool holders	<a href="#">B23B 29/00</a>
Machines for milling of window frames which may include slotting tools	<a href="#">B23C 3/128</a>
Planing or slotting of gear teeth	<a href="#">B23F 1/04</a> , <a href="#">B23F 5/12</a> , <a href="#">B23F 9/04</a>
Planing or slotting tools for making gear teeth	<a href="#">B23F 21/04</a>
Constructional features of machine tools in general	<a href="#">B23Q</a>
Features of copying devices	<a href="#">B23Q 35/00</a>

## Special rules of classification

The use of planing and slotting machines in metal working is not as widespread as it once was as a result of developments in milling machines and computer controls for milling machines. The field is therefore relatively slow-moving and classification in these groups is simply according to a literal interpretation of the group and subgroup headings. The feed movement of [B23D 1/28](#) refers to the relative feed movement of the tool and workpiece between the linear cutting passes.

## Synonyms and Keywords

In patent documents, the following words/expressions are often used with the meaning indicated:

"planing"	"shaping"
-----------	-----------

## B23D 3/00

**Planing or slotting machines cutting by relative movement of the tool and workpiece in a vertical or inclined straight line**

### Definition statement

*This place covers:*

Planing or slotting machines cutting by relative movement of the tool and workpiece in a vertical or inclined straight line. The tool or workpiece may be fed in a non-linear manner between passes to produce profiled stock.

## B23D 5/00

**Planing or slotting machines cutting otherwise than by relative movement of the tool and workpiece in a straight line**

### Definition statement

*This place covers:*

Planing or slotting machines cutting otherwise than by relative movement of the tool and workpiece in a straight line, i.e. in which the actual cutting stroke is not linear, so that non-prismatic surfaces can be produced..

## B23D 7/00

**Planing or slotting machines characterised only by constructional features of particular parts (constructional features of these parts per se [B23Q](#))**

### Definition statement

*This place covers:*

Planing or slotting machines characterised only by constructional features of particular parts. If characterising features relate to the pillars or to the cross beam, document should be classed in [B23D 7/04](#), rather than in [B23D 7/02](#), as these terms are more specific than the term "frame" of [B23D 7/02](#).

## B23D 9/00

**Hand-operated planing devices; Portable planing apparatus**

### Definition statement

*This place covers:*

Hand-operated planing devices; Portable planing apparatus

**B23D 11/00**

**Planing or slotting devices able to be attached to a machine tool, whether or not replacing an operative portion of the machine tool**

**Definition statement**

*This place covers:*

Planing or slotting devices able to be attached to a machine tool that is not primarily designed for planing or slotting, whether or not replacing an operative portion of the machine tool

**B23D 13/00**

**Tools or tool holders specially designed for planing or slotting machines (features applicable also to turning-machines [B23B 27/00](#), [B23B 29/00](#); for cutting gear teeth [B23F 21/04](#))**

**Definition statement**

*This place covers:*

Tools or tool holders specially designed for planing or slotting machines

**B23D 15/00**

**Shearing machines or shearing devices cutting by blades which move parallel to themselves**

**Definition statement**

*This place covers:*

Metal sheets, metal plates and metal bars or rods shearing devices comprising at least one blade which translates or roto-translates, in the latter case the blade being articulated about at least two pivoting links, the cooperating cutting edges of the shearing devices being offset or abutting.

**Special rules of classification**

Abutting means that the cutting edges pinch the material between them and the blades do not essentially cross.

**B23D 17/00**

**Shearing machines or shearing devices cutting by blades pivoted on a single axis (on an axis parallel to the blade [B23D 15/10](#); hand-held devices [B23D 29/00](#))**

**Definition statement**

*This place covers:*

Metal sheets, metal plates and metal bars or rods shearing devices comprising at least one elongated, possibly curved blade which rotates (completely or partially), or roto-translates, the blade being articulated about a single pivoting link, the cooperating cutting edges of the shearing devices being offset or abutting.

## References

### Limiting references

*This place does not cover:*

Disc blades	<a href="#">B23D 19/00</a>
-------------	----------------------------

### Special rules of classification

Abutting means that the cutting edges pinch the material between them and the blades do not essentially cross.

## B23D 19/00

Shearing machines or shearing devices cutting by rotary discs (by friction saw-discs [B23D 45/00](#))

### Definition statement

*This place covers:*

Shearing machines or shearing devices cutting by rotary discs, the cooperating cutting edges of the shearing devices being offset or abutting.

### Special rules of classification

Abutting means that the cutting edges pinch the material between them and the blades do not essentially cross.

## B23D 21/00

Machines or devices for shearing or cutting tubes (as additional equipment for deep-drawing presses [B21D 24/16](#))

### Definition statement

*This place covers:*

Devices for shearing (the cooperating cutting edges of the shearing devices being offset or abutting) or cutting tubes. The term tube is to be intended as a profile showing a continuous, convex, closed section.

## References

### Limiting references

*This place does not cover:*

Cutting profiles	<a href="#">B23D 23/00</a>
Sawing devices with circular blades for cutting tubes	<a href="#">B23D 45/12</a>
Cutting by turning	<a href="#">B23B</a>
Cutting by milling	<a href="#">B23C</a>

### Special rules of classification

Abutting means that the cutting edges pinch the material between them and the blades do not essentially cross.

## B23D 23/00

### Machines or devices for shearing or cutting profiled stock (hand-held devices [B23D 29/00](#))

#### Definition statement

*This place covers:*

Devices for shearing (the cooperating cutting edges of the shearing devices being offset or abutting) or cutting metal profiles showing a discontinuous, concave or open section, window coverings, window or door profiles.

#### References

##### Limiting references

*This place does not cover:*

Cutting tubes	<a href="#">B23D 21/00</a>
Turning	<a href="#">B23B</a>
Milling	<a href="#">B23C</a>

#### Special rules of classification

Abutting means that the cutting edges pinch the material between them and the blades do not essentially cross.

## B23D 25/00

### Machines or arrangements for shearing stock while the latter is travelling otherwise than in the direction of the cut (controlling slack in travelling flexible stock [B21C 47/10](#))

#### Definition statement

*This place covers:*

Machines or arrangements for shearing stock while the latter is travelling otherwise than in the direction of the cut, the cooperating cutting edges of the shearing devices being offset or abutting (i.e. flying shears).

#### Special rules of classification

Abutting means that the cutting edges pinch the material between them and the blades do not essentially cross.

## B23D 27/00

### Machines or devices for cutting by a nibbling action

#### Definition statement

*This place covers:*

Machines or devices comprising at least one punch like tool and adapted to produce a line of cut which is the result of a sequence of overlapping punching operations.



## B23D 29/00

Hand-held metal-shearing or metal-cutting devices (with nibbling action [B23D 27/02](#); hand-operated devices for metal-cutting otherwise than by shearing [B26B](#))

### Definition statement

*This place covers:*

Devices in which the cooperating cutting edges of the shearing devices are offset or abutting.

### References

#### Limiting references

*This place does not cover:*

Hand operated shearing devices comprising abutting cutting edges	<a href="#">B26B</a>
--	----------------------

### Special rules of classification

Abutting means that the cutting edges pinch the material between them and the blades do not essentially cross.

## B23D 31/00

Shearing machines or shearing devices covered by none or more than one of the groups [B23D 15/00](#) - [B23D 29/00](#); Combinations of shearing machines

### Definition statement

*This place covers:*

In addition to combinations of similar or different shearing machines as defined in the preceding main groups, breaking machines (e.g. for rails, connecting rods, rings), demolition shears, devices for trimming deep drawn products outside the press.

### References

#### Informative references

*Attention is drawn to the following places, which may be of interest for search:*

Disintegrating by knives	<a href="#">B02C 18/00</a>
Trimming combined with deep-drawing presses	<a href="#">B21D 24/16</a>

## B23D 33/00

Accessories for shearing machines or shearing devices (feeding stock to machines or removing stock [B21D 43/00](#))

### Definition statement

*This place covers:*

Feeding, holding, positioning or guiding stock directly into the operating area of the shearing machines or devices, devices for indicating the position of the cut.

## References

### Informative references

Attention is drawn to the following places, which may be of interest for search:

Indicating the position of the cut	<a href="#">B21D 28/04</a>
------------------------------------	----------------------------

## Special rules of classification

The accessories are meant to be part of the shear, a feeder of a general purpose should be classified in [B21D 43/00](#) (see title)

## B23D 35/00

### Tools for shearing machines or shearing devices; Holders or chucks for shearing tools

#### Definition statement

*This place covers:*

Shapes and sections of the cutting members, means for mounting and adjusting the position of cutting members

#### Special rules of classification

Shapes can be any shape, sections are profiles of cutting members as viewed across their sections

## B23D 36/00

### Control arrangements specially adapted for machines for shearing or similar cutting, or for sawing, stock which the latter is travelling otherwise than in the direction of the cut

#### Definition statement

*This place covers:*

Control means for coordinating the action between feeding means and shearing means

## References

### Informative references

Attention is drawn to the following places, which may be of interest for search:

Control means for cutting non metallic workpieces	<a href="#">B26D 5/00</a>
---	---------------------------

## B23D 37/00

### Broaching machines or broaching devices

#### Definition statement

*This place covers:*

Broaching machines or devices. Broaching is similar to shaping/planing ([B23D 1/00-B23D 13/00](#)) except that a tool with multiple teeth is employed. The difference in height between successive teeth

on a broaching tool determines the feed, and hence the chip thickness, whereas in shaping or planing the feed is determined by a relative movement between tool and workpiece between each pass.

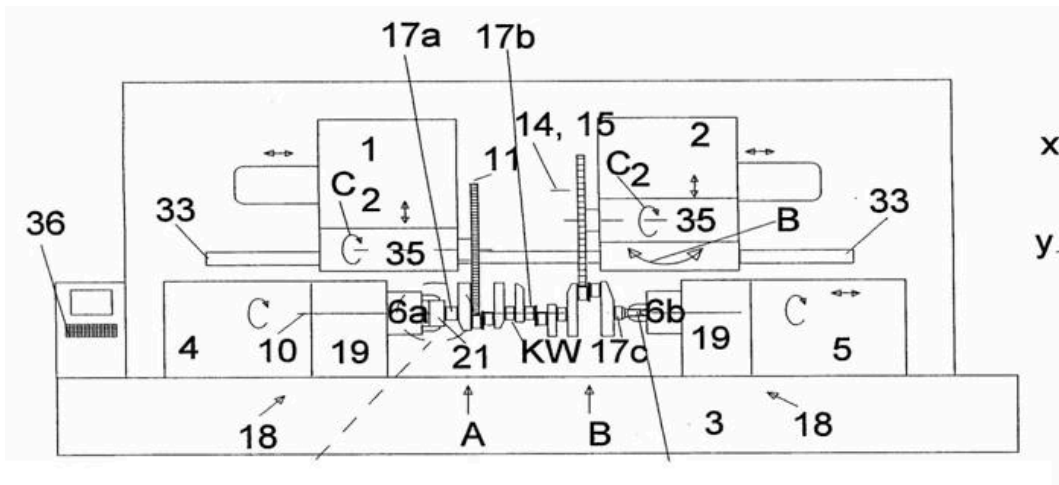

Broaching of cylindrical workpieces e.g. crankshafts [B23D 37/005](#)

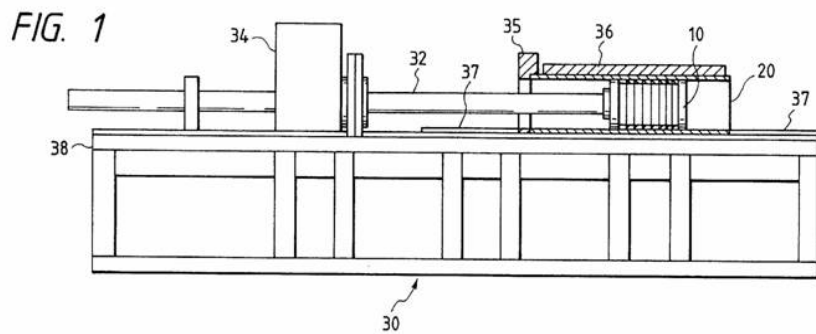

Horizontal broaching machine [B23D 37/04](#)

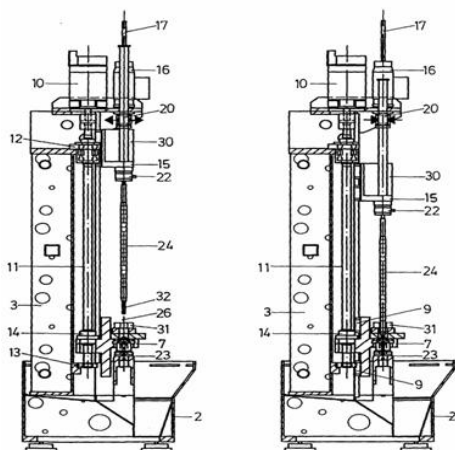

Vertical Broaching machine for inner surface [B23D 37/10](#)

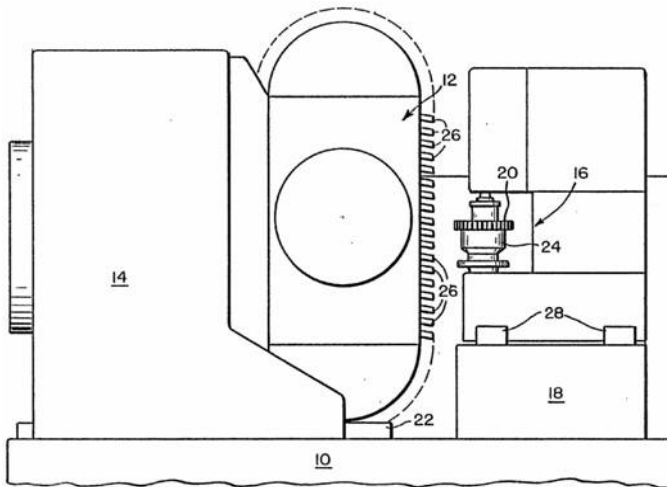

Broaching machine with tools on chain [B23D 37/18](#)

### Relationships with other classification places

Broaching is similar to shaping/planning ([B23D 1/00-B23D 13/00](#)) except that a tool with multiple teeth is employed. The difference in height between successive teeth on a broaching tool determines the feed, and hence the chip thickness, whereas in shaping or planing the feed is determined by a relative movement between tool and workpiece between each pass.

### References

#### Limiting references

*This place does not cover:*

Making gears or the like by broaching	<a href="#">B23F</a>
Multi stage processes involving broaching and also other operations classed in <a href="#">B23B</a> , <a href="#">B23C</a> , <a href="#">B23E</a> , making particular items.	<a href="#">B23P 13/00</a> , <a href="#">B23P 15/00</a> , <a href="#">B23P 23/00</a>
Details of machine tools and accessories not related to the operation being performed including:	<a href="#">B23Q</a>
- tool changing	<a href="#">B23Q 3/155</a>
- conveying workpiece into and from machine	<a href="#">B23Q 7/00</a>
- evacuation of swarf,	<a href="#">B23Q 11/0042</a>
- guarding & protective coverings	<a href="#">B23Q 11/08</a>
Adaptive control and/or computer controls for broaching processes	<a href="#">B23Q 15/00</a> , <a href="#">G05B 15/02</a>
- measuring or sensing	<a href="#">B23Q 17/00</a>

#### Informative references

*Attention is drawn to the following places, which may be of interest for search:*

Turning of crankshafts or camshafts	<a href="#">B23B 5/18</a>
Fixation of cutting inserts in metal-removing tools	<a href="#">B23B 27/16</a> , <a href="#">B23C 5/22</a>
Milling of crankshafts	<a href="#">B23C 3/06</a>
Milling of camshafts	<a href="#">B23C 3/08</a>

Construction of milling tools	<a href="#">B23C 5/00</a>
Broaching of gears	<a href="#">B23F 1/08</a> , <a href="#">B23F 5/28</a> , <a href="#">B23F 9/003</a>
Broach-milling tools for making gears	<a href="#">B23F 21/24</a>
Broaching tools for making gears	<a href="#">B23F 21/26</a>
Manufacture of crankshafts or camshafts	<a href="#">B23P 15/00</a>
Constructional features of machine tools in general	<a href="#">B23Q</a>

### Special rules of classification

[B23D 37/005](#) for rotary broaching takes precedence over all other subgroups

Classification in this group is simply according to a literal interpretation of the group and subgroup headings, taking into account the notes concerning precedence and the references contained within the subgroups. The term "horizontally arranged" of [B23D 37/02](#) should be understood a meaning arranged so the teeth or the broach are arranged in a generally horizontal plane and the tool moves horizontally with respect to the workpiece. Similarly the teeth of the broaching tools of [B23D 37/08](#) are arranged in a generally vertical plane and the tool describes a generally vertical motion with respect to the workpiece.

## B23D 39/00

### Accessories for broaching machines or broaching devices

#### Definition statement

*This place covers:*

Accessories for broaching machines or broaching devices. Broaching is similar to shaping/planing ([B23D 1/00-B23D 13/00](#)) except that a tool with multiple teeth is employed. The difference in height between successive teeth on a broaching tool determines the feed, and hence the chip thickness, whereas in shaping or planing the feed is determined by a relative movement between tool and workpiece between each pass.

### Special rules of classification

Classification in this group is simply according to a literal interpretation of the group and subgroup headings, taking into account the notes concerning precedence and the references contained within the subgroups.

## B23D 41/00

### Broaching machines or broaching devices characterised only by constructional features of particular parts (constructional features of these parts per se [B23Q](#))

#### Definition statement

*This place covers:*

Broaching machines or broaching devices characterised only by constructional features of particular parts. Broaching is similar to shaping/planing ([B23D 1/00-B23D 13/00](#)) except that a tool with multiple teeth is employed. The difference in height between successive teeth on a broaching tool determines the feed, and hence the chip thickness, whereas in shaping or planing the feed is determined by a relative movement between tool and workpiece between each pass.

## Special rules of classification

Classification in this group is simply according to a literal interpretation of the group and subgroup headings, taking into account the notes concerning precedence and the references contained within the subgroups.

## B23D 43/00

### Broaching tools (for cutting gear teeth [B23F 21/26](#))

#### Definition statement

*This place covers:*

Broaching tools. Broaching is similar to shaping/planning ([B23D 1/00-B23D 13/00](#)) except that a tool with multiple teeth is employed. The difference in height between successive teeth on a broaching tool determines the feed, and hence the chip thickness, whereas in shaping or planing the feed is determined by a relative movement between tool and workpiece between each pass. Broaching tools are multi-toothed cutting tools in which the geometrically defined functional edges of the tool teeth are so related to one another that the tip of one tooth (or set of teeth) extends further than that of an adjacent tooth (or set of teeth) from a datum line interior to the tool extending parallel to the path of relative movement between the tool and the work and in whose operation the teeth successively engage the work, each tooth or set of teeth removing an amount of material determined by its relationship to the adjacent tooth (or set of teeth). In the case of rotary broaches no relative movement is necessary between the axis of the tool and the work in order to effect cutting.

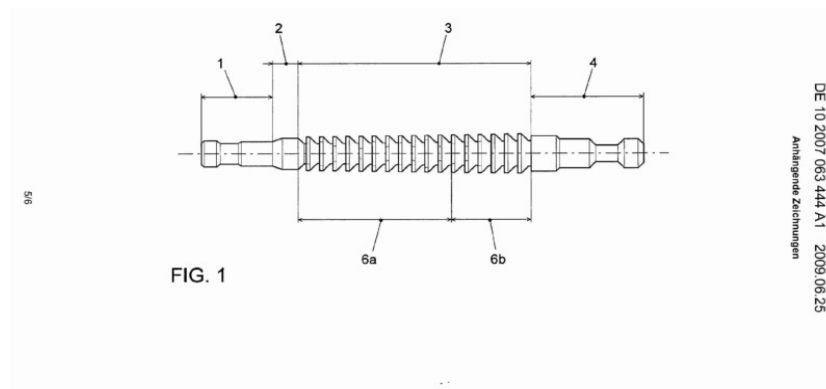

#### linear broach [B23D 43/02](#)

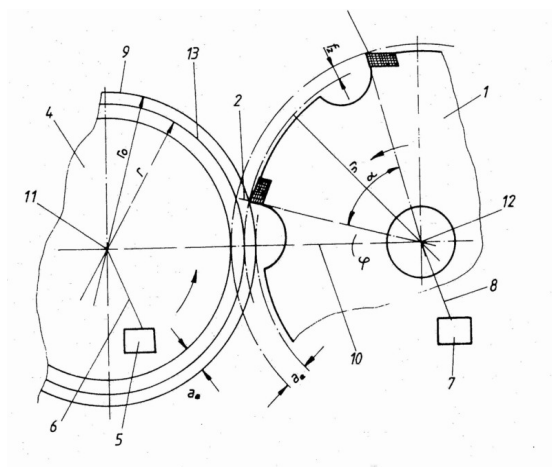

#### Rotational broach [B23D 43/06](#)

## Special rules of classification

Classification in this group is simply according to a literal interpretation of the group and subgroup headings, taking into account the notes concerning precedence and the references contained within the subgroups.

## B23D 45/00

**Sawing machines or sawing devices with circular saw blades or with friction saw discs (shearing machines with rotary discs [B23D 19/00](#) - [B23D 25/00](#))**

### Definition statement

*This place covers:*

- Machines or devices for sawing in general or sawing metal ([B23D 45/00](#), [B23D 49/00](#), [B23D 53/00](#), [B23D 57/00](#))
- Constructional features of particular parts thereof ([B23D 47/00](#), [B23D 51/00](#), [B23D 55/00](#))
- Accessories specially designed for sawing machines or sawing devices ([B23D 59/00](#))
- Tools for sawing machines or sawing devices, clamping devices for these tools, saw blades ([B23D 61/00](#))
- Dressing the tools of sawing machines or sawing devices ([B23D 63/00](#))
- Making tools for sawing machines or sawing devices ([B23D 65/00](#))

### Relationships with other classification places

[B23D](#) is the main entry for sawing. Other large areas covering sawing are [B27B](#) (sawing wood or similar material) and [B28D 1/02](#) (sawing stone). Precedence is given to [B23D](#). Features not restricted to a particular type of saw are classified in [B23D](#). However, such features are classified in [B27B](#) if a more specific entry exists in [B27B](#), for example:

- [B27B 5/30](#): mounting/securing devices for circular saw blades or spindles
- [B27B 5/38](#): braking devices for the circular saw blade or the spindle
- [B27B 17/00](#): details of chain saws, equipment for chain saws
- [B27B 27/00](#): guide fences or stops
- [B27B 33/14](#): saw chains

### References

#### Limiting references

*This place does not cover:*

Shearing machines with rotary discs	<a href="#">B23D 19/00</a> - <a href="#">B23D 25/00</a>
Control of machines with circular saw blades for sawing stock while the latter is travelling otherwise than in the direction of the cut	<a href="#">B23D 36/00</a>
Constructional features of particular parts per se	<a href="#">B23Q</a>
Grinders for cutting-off	<a href="#">B24B 27/06</a>
Details or components, e.g. casings, bodies, of portable power-driven saws not particularly related to the operation performed	<a href="#">B25F 5/00</a>
Safety guards or devices specially designed for saws	<a href="#">B27G 19/00</a> , <a href="#">B23Q 11/00</a> , <a href="#">F16P</a>

**Application-oriented references**

Examples of places where the subject matter of this place is covered when specially adapted, used for a particular purpose, or incorporated in a larger system:

Sawing wood or similar material	<a href="#">B27B</a>
Sawing stone or stone-like materials	<a href="#">B28D 1/02</a>
Accessories specially adapted for use with machines for sawing of gems, jewels, crystals	<a href="#">B28D 5/0058</a>
Sawing gems, jewels, crystals with discs or wheels	<a href="#">B28D 5/022</a>
Sawing gems, jewels, crystals with blades or wires	<a href="#">B28D 5/042</a> , <a href="#">B28D 5/045</a>
Accessories specially adapted for use with machines or devices for sawing stone	<a href="#">B28D 7/00</a>

**Informative references**

Attention is drawn to the following places, which may be of interest for search:

Saws specially adapted for pruning or debranching	<a href="#">A01G 3/08</a>
Sawing apparatus specially adapted for felling trees	<a href="#">A01G 23/091</a>
Meat or bone saws	<a href="#">A22B 5/20</a>
Surgical saws	<a href="#">A61B 17/14</a>
Saws for dentistry	<a href="#">A61C 3/12</a>
Grinders for cutting-off	<a href="#">B24B 27/06</a>
Auxiliary devices facilitating proper operation of wood saws	<a href="#">B27G 19/00</a>

**Glossary of terms**

In this place, the following terms or expressions are used with the meaning indicated:

Feeding work	moving a workpiece into engagement with a saw blade while sawing
Conveying or transporting work	moving a workpiece before, after or between sawing operations
Discharging work	moving a workpiece away from a saw blade after sawing

**B23D 45/003**

{for particular purposes}

**Definition statement**

This place covers:

Features of saws which are specific for a particular application, for example, devices for sawing venetian window blinds, railroad rails, pallets.

**References****Informative references**

Attention is drawn to the following places, which may be of interest for search:

Machines for disassembling pallets	<a href="#">B23P 19/041</a>
------------------------------------	-----------------------------



Sectioning or slitting rails, e.g. by sawing, shearing, flame-cutting	<a href="#">E01B 31/04</a>
Devices or accessories for making or mounting lamellar blinds or parts thereof	<a href="#">E06B 9/266</a>

**B23D 45/006**

{with means to attach the sawing device to the workpiece}

**References**

**Informative references**

Attention is drawn to the following places, which may be of interest for search:

Sectioning or slitting rails, e.g. by sawing, shearing, flame-cutting	<a href="#">E01B 31/04</a>
---	----------------------------

**B23D 45/025**

{Radial sawing machines}

**Definition statement**

This place covers:

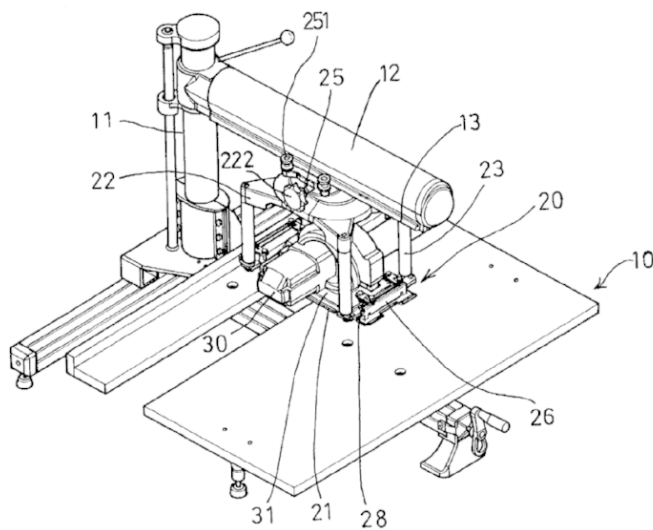

FIG. 1

Patent Application Publication Sep. 18, 2003 Sheet 1 of 7 US 2003/0172788 A1

(US2003/017288 A1)

## B23D 45/028

{the saw carriage being mounted on a pivoted lever}

### Definition statement

*This place covers:*

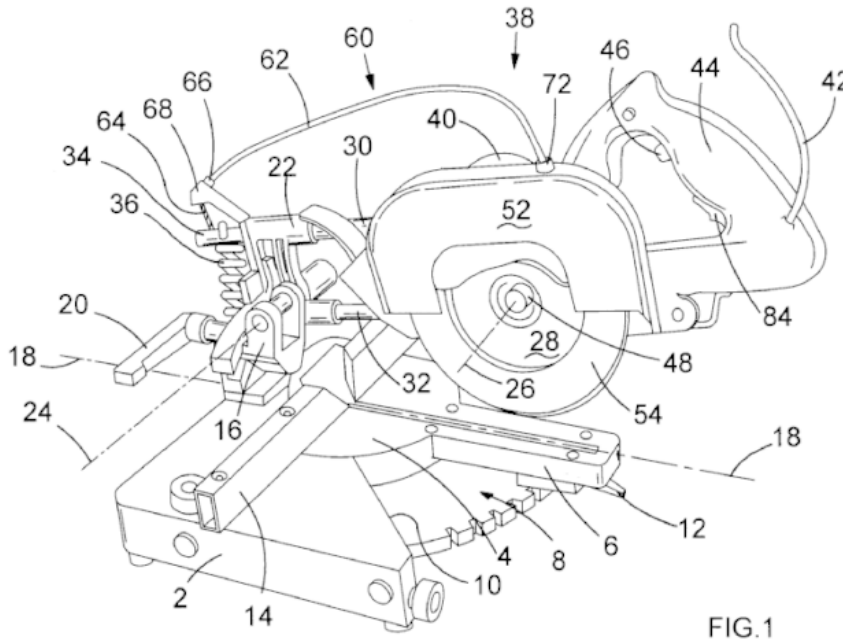

(EP 1 772 221 A1)

## B23D 47/00

**Sawing machines or sawing devices working with circular saw blades, characterised only by constructional features of particular parts (constructional features of these parts per se [B23Q](#); details or components, e.g. casings, bodies, of portable power-driven tools not particularly related to the operation performed [B25F 5/00](#))**

### References

#### Limiting references

*This place does not cover:*

Details or components, e.g. casings, bodies, of portable power-driven saws not particularly related to the operation performed	<a href="#">B25F 5/00</a>
--	---------------------------

#### Informative references

*Attention is drawn to the following places, which may be of interest for search:*

Circular saw blades, clamping devices therefor	<a href="#">B23D 61/02</a>
Constructional features of particular parts per se	<a href="#">B23Q</a>
Details; Component parts; Accessories for circular wood saws	<a href="#">B27B 5/29</a>
Mounting or securing circular saw blades or saw spindles	<a href="#">B27B 5/30</a> - <a href="#">B27B 5/36</a>

Devices for braking the circular saw blade or the saw spindle; Devices for damping vibrations of the circular saw blade, e.g. silencing	<a href="#">B27B 5/38</a>
Arrangements for adjusting the cutting depth or the amount of tilting of portable power-driven circular saws for manual operation	<a href="#">B27B 9/02</a>
Guiding equipment for portable power-driven circular saws for manual operation	<a href="#">B27B 9/04</a>
Guide fences	<a href="#">B27B 27/00</a>

**Special rules of classification**

Reference [B23Q](#) is non-limiting in the main group [B23D 47/00](#). CPC will be updated/corrected once this inconsistency is resolved in IPC.

**B23D 47/128**

**{of means to position the saw blade at a specified angle when adjusting about an axis parallel to the work support surface}**

**Definition statement**

*This place covers:*

A mechanism for locking or otherwise holding the blade at an angle when adjusting about an axis parallel to the work support surface. Generic blade pivoting need not be placed here.

Illustrative example of subject matter classified in this place:

Note, in the figure below, bevel adjustment mechanism 40 for adjusting rotational angle about axis 48 is illustrated as including a locking knob.

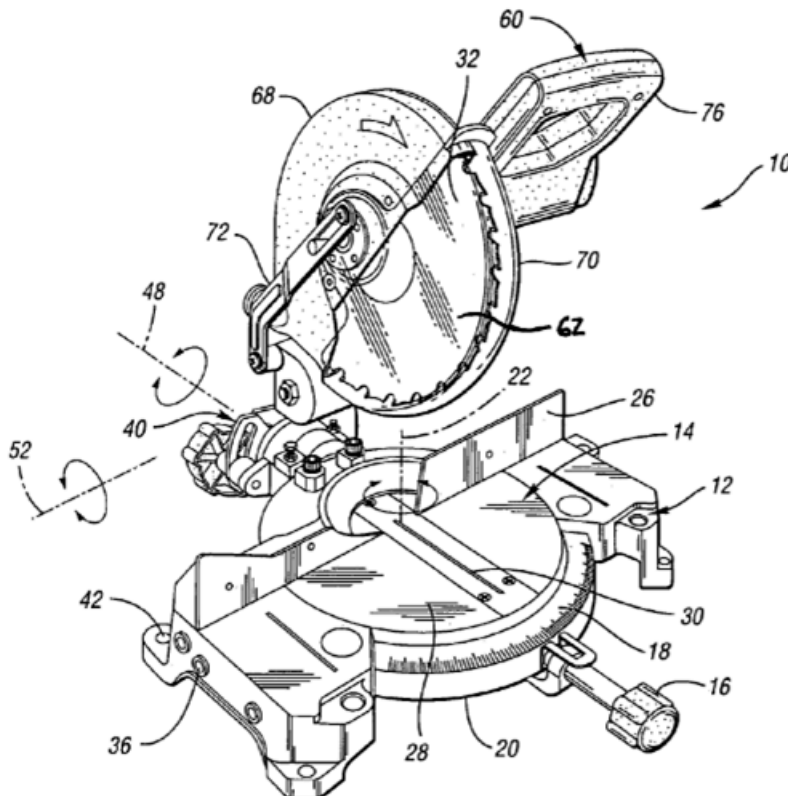

## B23D 47/132

{of means to position the saw blade at a specified angle when adjusting about an axis perpendicular to the work support surface}

### Definition statement

*This place covers:*

A mechanism for locking or otherwise holding the blade at an angle when adjusting about an axis perpendicular to the work support surface. Generic blade pivoting need not be placed here.

Illustrative example of subject matter classified in this place:

Note, in the figure below, locking mechanism includes lever 134 which is actuated to disengage a detent from one of the recesses 42.

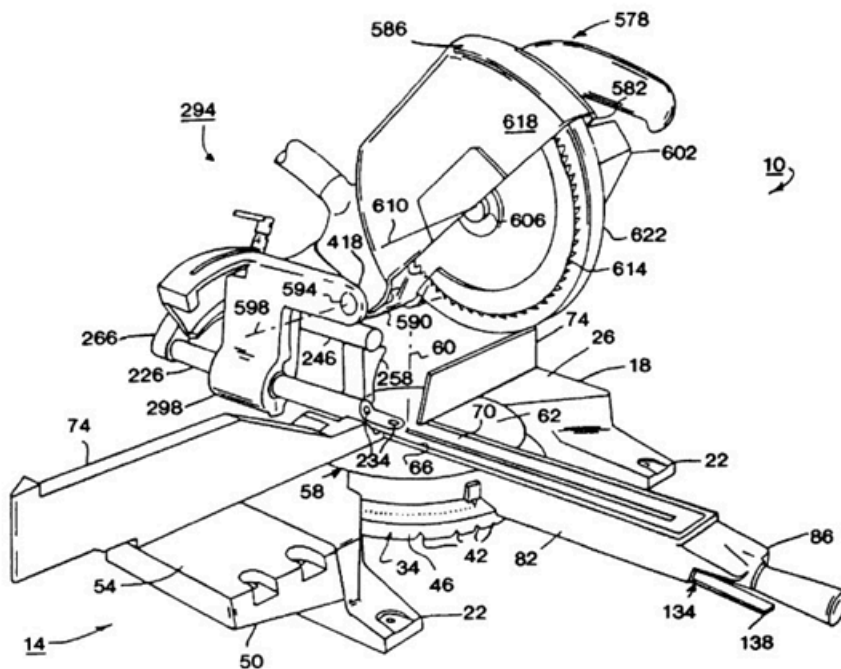

## B23D 49/00

Machines or devices for sawing with straight reciprocating saw blades, e.g. hacksaws

### References

#### Informative references

Attention is drawn to the following places, which may be of interest for search:

Hacksaws with bows adjustable in length or height	<a href="#">B23D 51/12</a>
---	----------------------------

**B23D 49/012****{combined with tool of another type}****Definition statement***This place covers:*

Illustrative example of subject matter classified in this place:

Note, in the figure below, a reciprocating blade combined with a rotating blade.

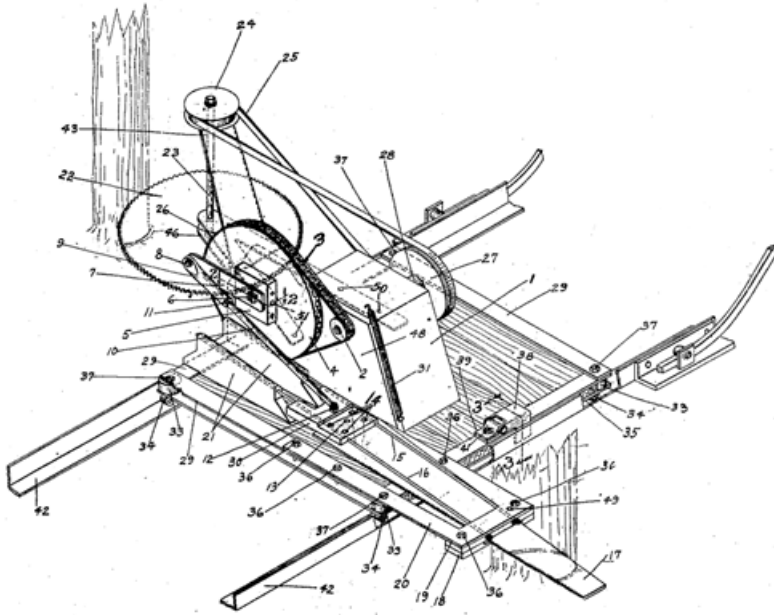
**B23D 49/013****{with means to change to another type of tool}****Definition statement***This place covers:*

Illustrative examples of subject matter classified in this place:

Note, in Fig. 1 below, a reciprocating saw that has been converted to a sander.

1.

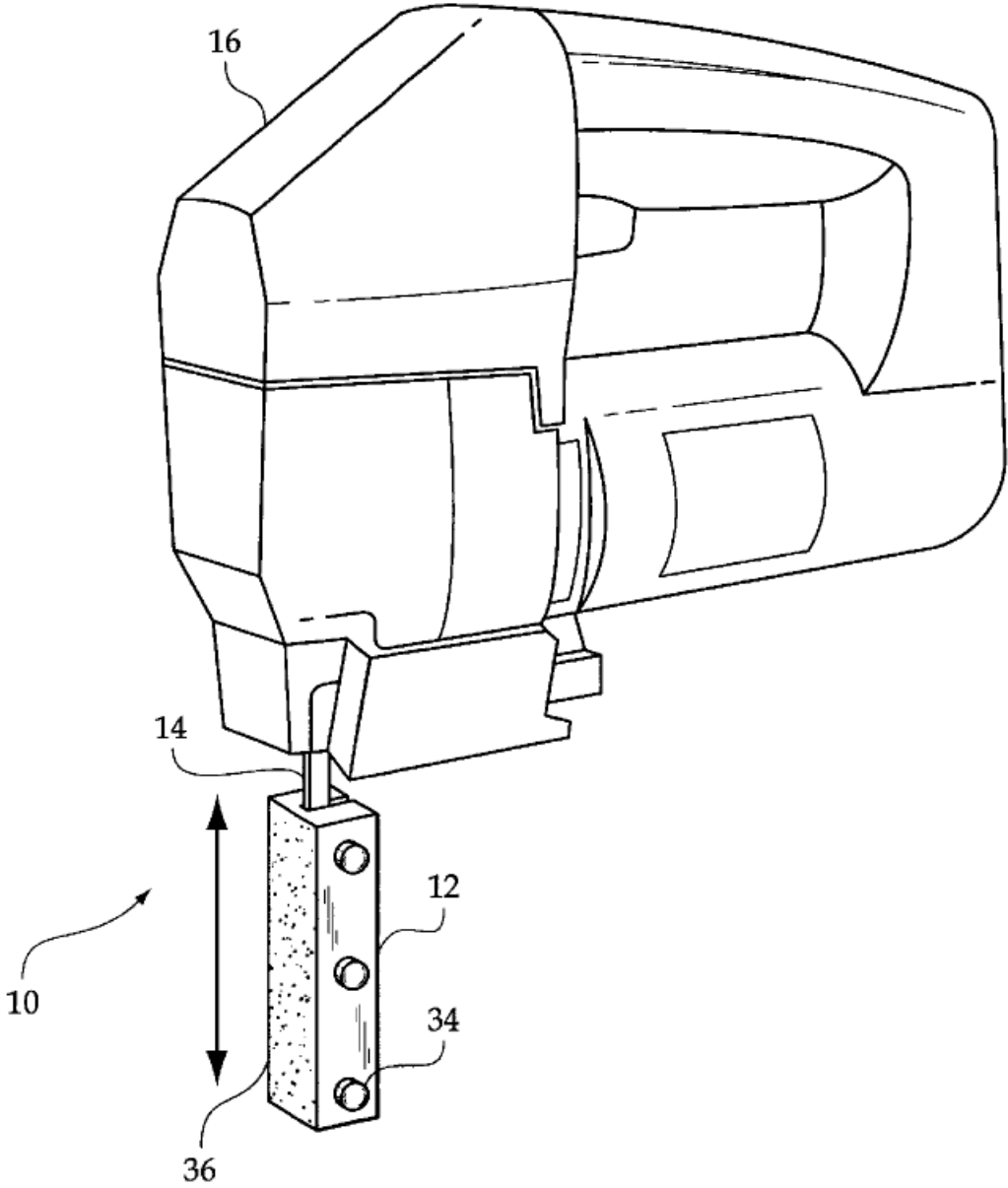

Note, in Fig. 2 below, a reciprocating saw that has been converted to a rotary saw.

2.

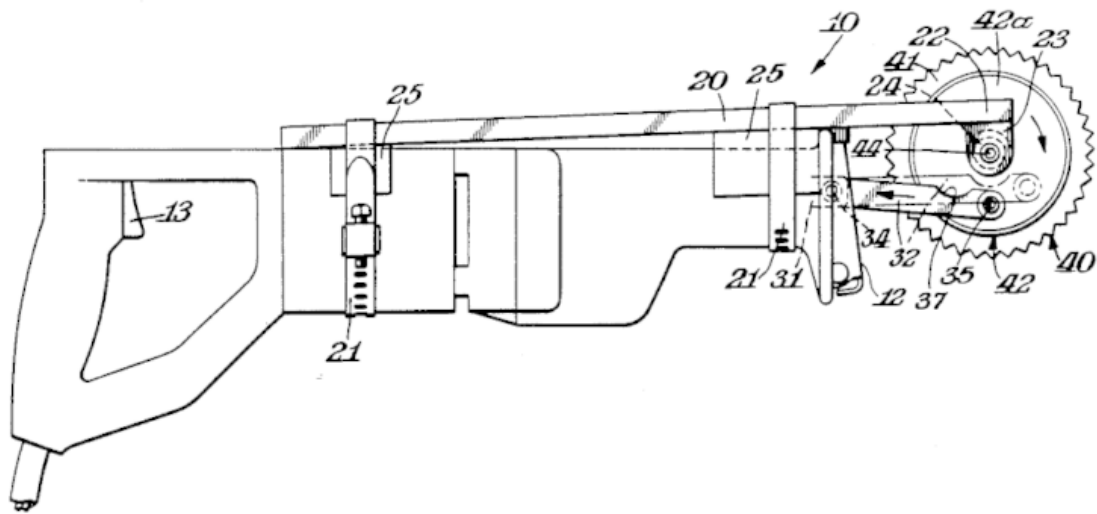

### B23D 49/125

{with wire-type frames}

### Definition statement

This place covers:

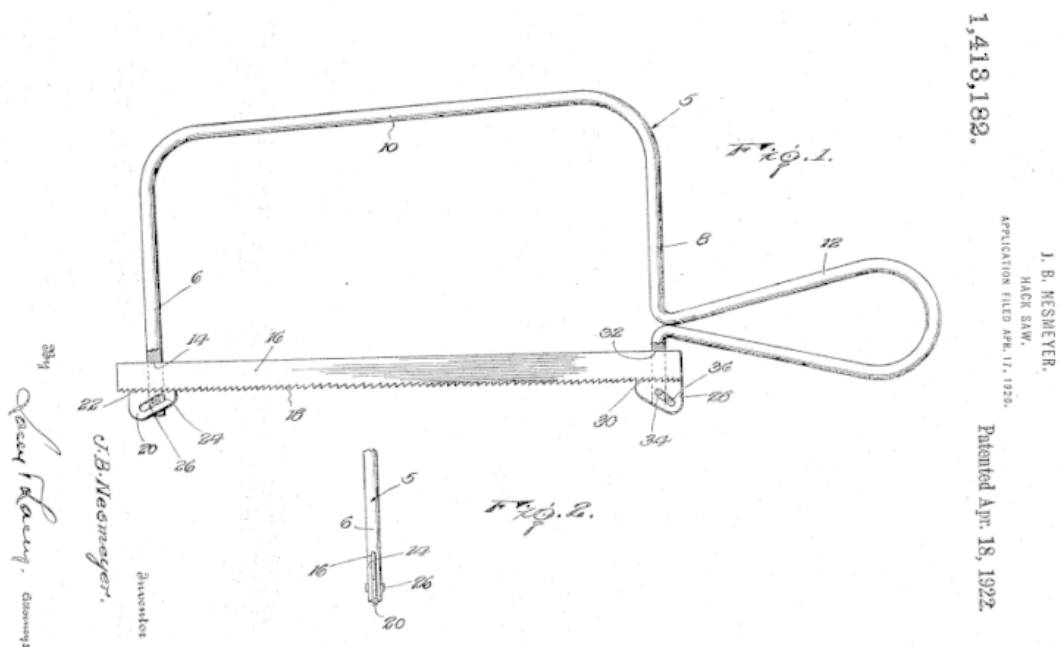

(US 1 413 182)

## B23D 49/14

Pad saws {(B23D 49/105, B23D 49/11, B23D 49/16 take precedence)}

### Definition statement

This place covers:

Aug. 12, 1952

B. A. DERR

2,606,584

HANDSAW

Filed May 15, 1950

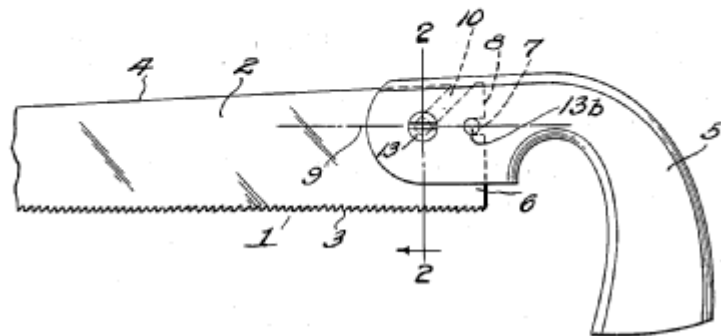

(US 2 606 584)

## B23D 49/162

{Pad sawing devices}

### Definition statement

This place covers:

Fig. 1

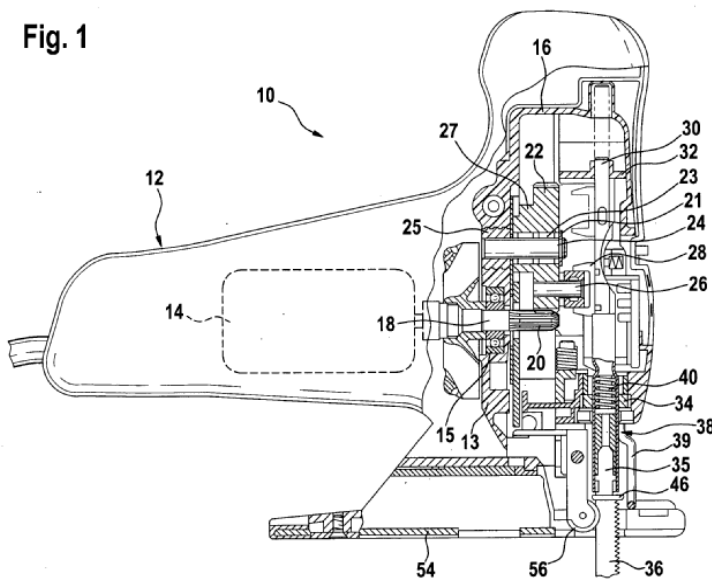

DE 10 2008 003 739 A1 2009.07.16  
Anhängende Zeichnungen



(DE 10 2008 003 739 A1)

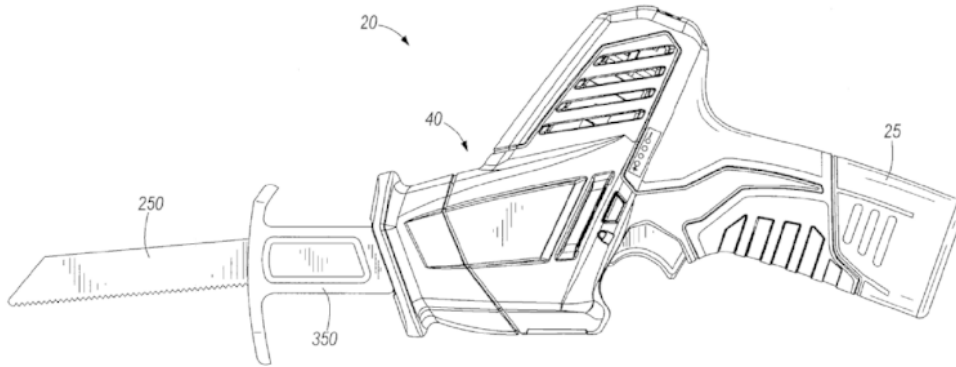
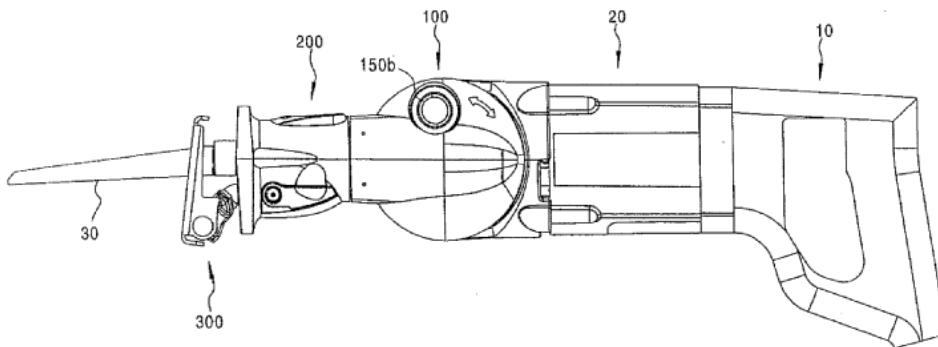

FIG. 1

Patent Application Publication Jul. 1, 2010 Sheet 1 of 14 US 2010/0162579 A1

(US 2010/0162579 A1)



EP 1 894 304 A1

(EP 1 884 304 A1)

EP 1 325 790 A2

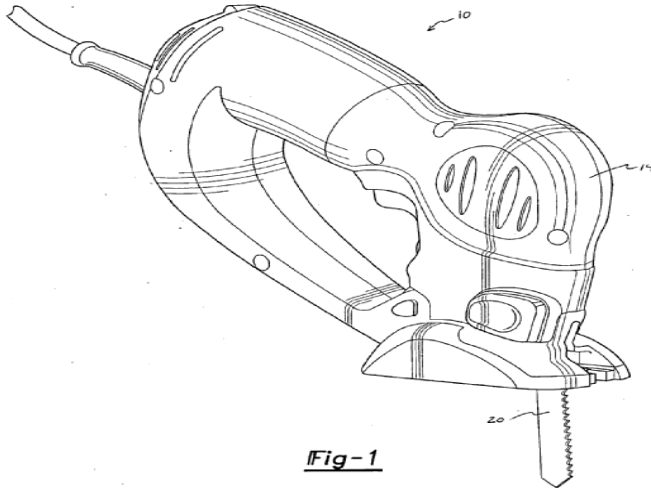

(EP 1 325 790 A2)

## B23D 49/165

{with means to move the saw blades in an orbital path}

### Definition statement

*This place covers:*

U.S. Patent    Dec. 16, 2003    Sheet 8 of 13    US 6,662,455 B2

FIG. 16

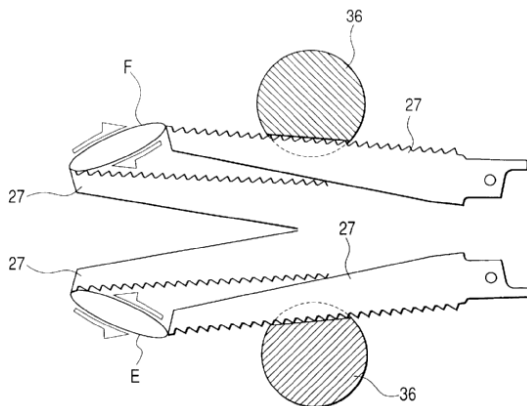

US 6 662 455 B2

U.S. Patent Apr. 1, 2008 Sheet 3 of 5 US 7,350,302 B2

**FIG. 4**

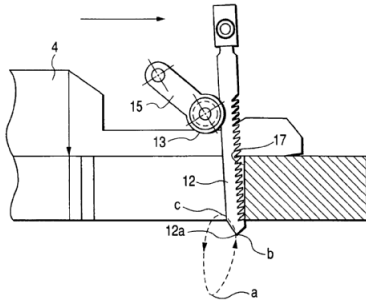

**FIG. 5**

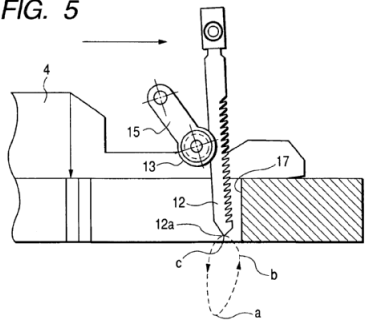

US 7 350 302 B2

**B23D 49/167**

{with means to adjust the guide plate or with means to adjust the plane in which the saw blade moves}

**Definition statement**

*This place covers:*

DE 10 2008 001 762 A1 2009.11.19  
Anhängende Zeichnungen

**Fig. 1**

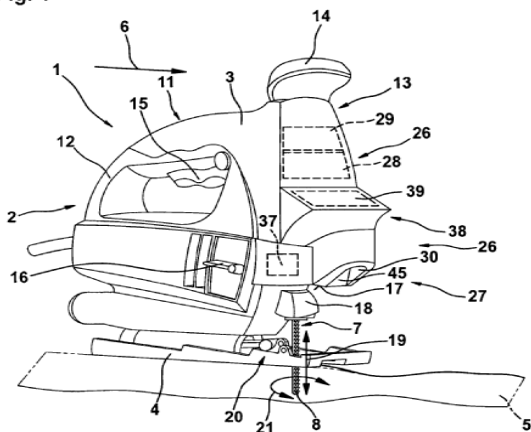

DE 10 2008 001 762 A1 2009.11.19

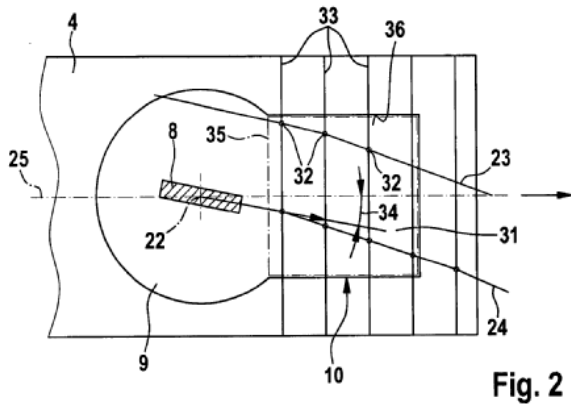

the saw blade being rotatable around its longitudinal axis during sawing for sawing along a curved path (DE 10 2008 001 762 A1)

DE 10 2007 034 529 A1 2009.01.29  
Anhängende Zeichnungen

Fig. 1

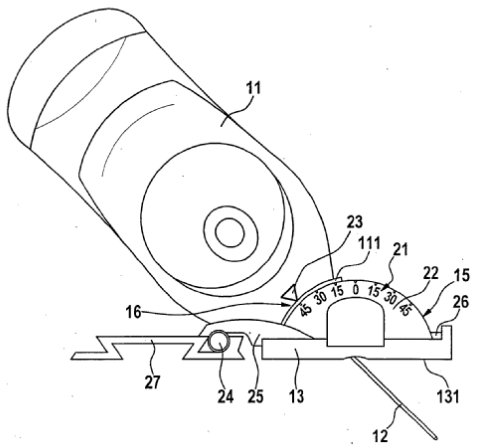

the saw being angularly adjustable relative to its foot plate

(DE 10 2007 034 529 A1)

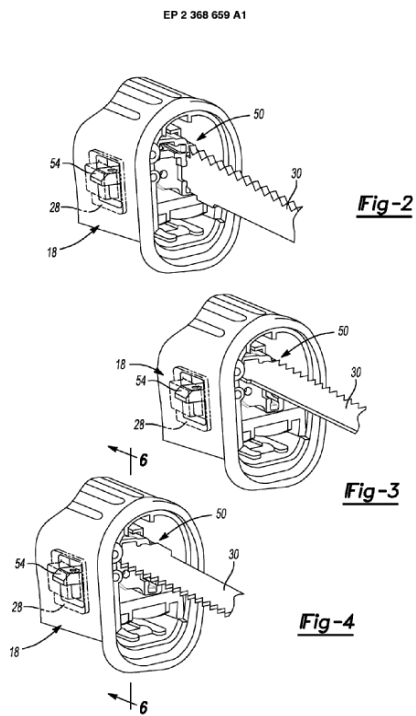

the saw blade being mountable in different planes (EP 2 368 659 A1)

Patent Application Publication Jun. 24, 2010 Sheet 2 of 8 US 2010/0154231 A1

EP 1 884 304 A1

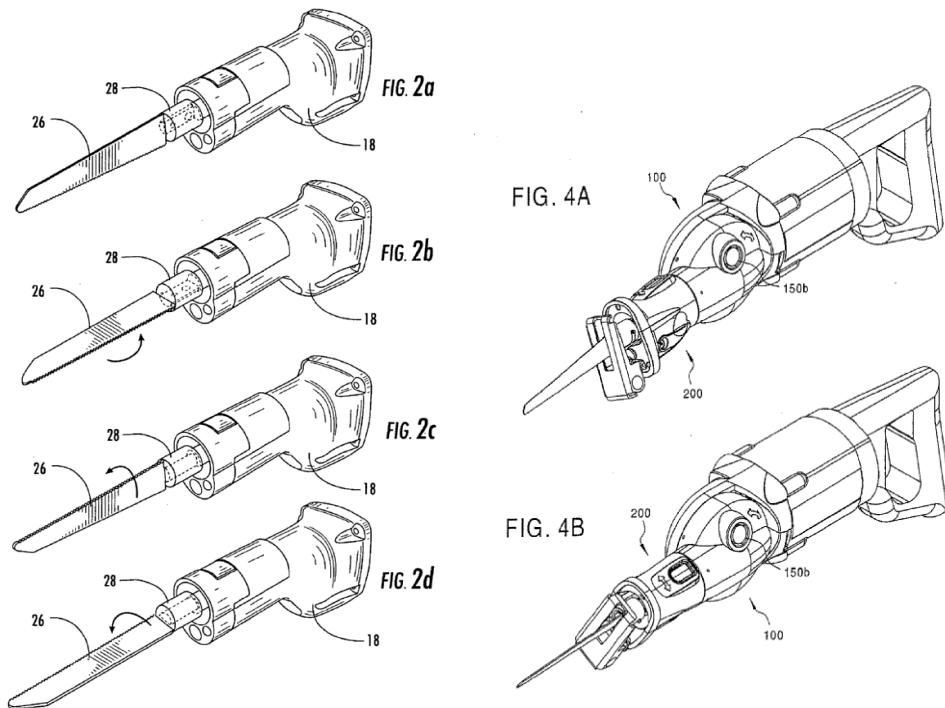

the saw blade being adjustable in different planes (US 2010/0154231 A1 and EP 1 884 304 A1)

**B23D 49/211**

{whereby the saw carrier pivots about an axis to feed the saw blade into the workpiece during cutting}

**Definition statement**

*This place covers:*

Illustrative example of subject matter classified in this place:

Note, in the figure below, the pivoting of the reciprocating saw carriage.

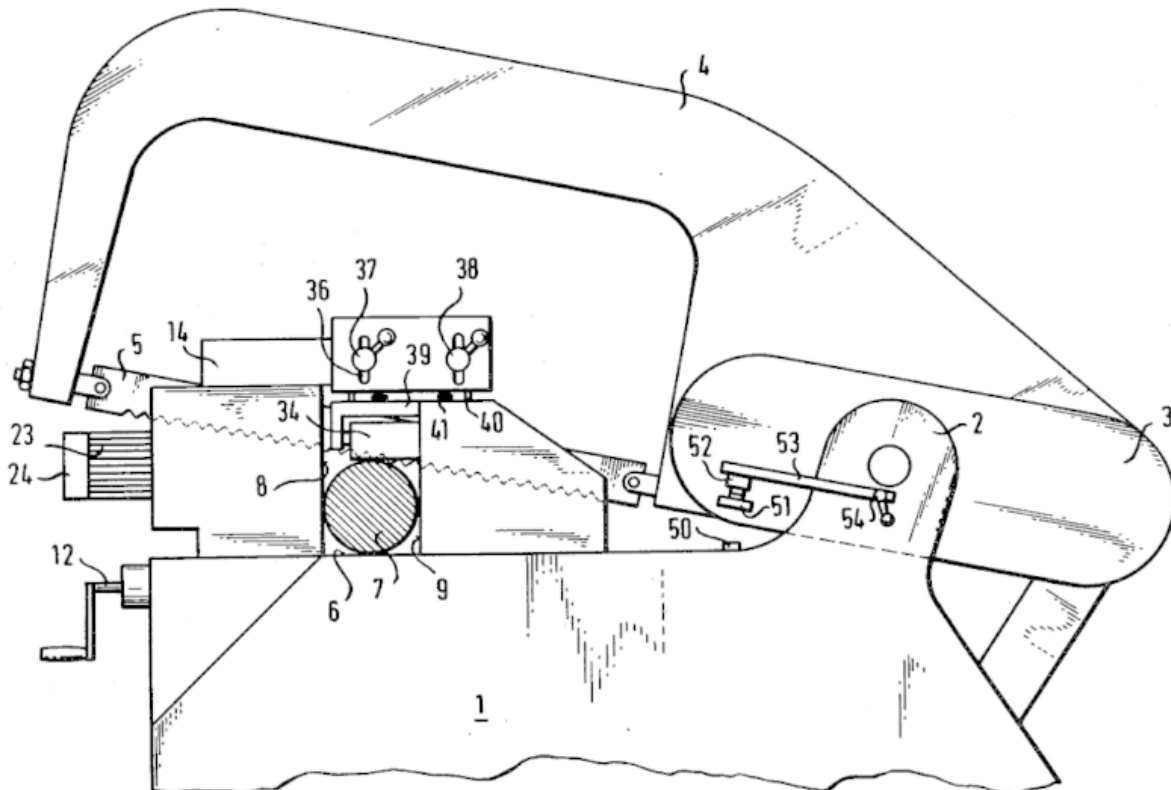
**B23D 51/00**

Sawing machines or sawing devices working with straight blades, characterised only by constructional features of particular parts (constructional features of these parts per se [B23Q](#); details or components, e.g. casings, bodies, of portable power-driven tools not particularly related to the operation performed [B25F 5/00](#)); Carrying or attaching means for tools, covered by this subclass, which are connected to a carrier at both ends

**References****Limiting references**

*This place does not cover:*

Straight saw blades	<a href="#">B23D 61/12</a>
---------------------	----------------------------

Constructional features of particular parts per se	<a href="#">B23Q</a>
Details or components, e.g. casings, bodies, of portable power-driven saws not particularly related to the operation performed	<a href="#">B25F 5/00</a>
Guide fences	<a href="#">B27B 27/00</a>

**Informative references**

Attention is drawn to the following places, which may be of interest for search:

Arrangements for stretching the saw blade of hand saws without power drive for sawing wood	<a href="#">B27B 21/06</a>
--	----------------------------

**B23D 51/026**

{by plural opposed guide surfaces}

**Definition statement**

*This place covers:*

Illustrative example of subject matter classified in this place:

Note, in the figure below, how a guide is contacting both sides of the reciprocating blade.

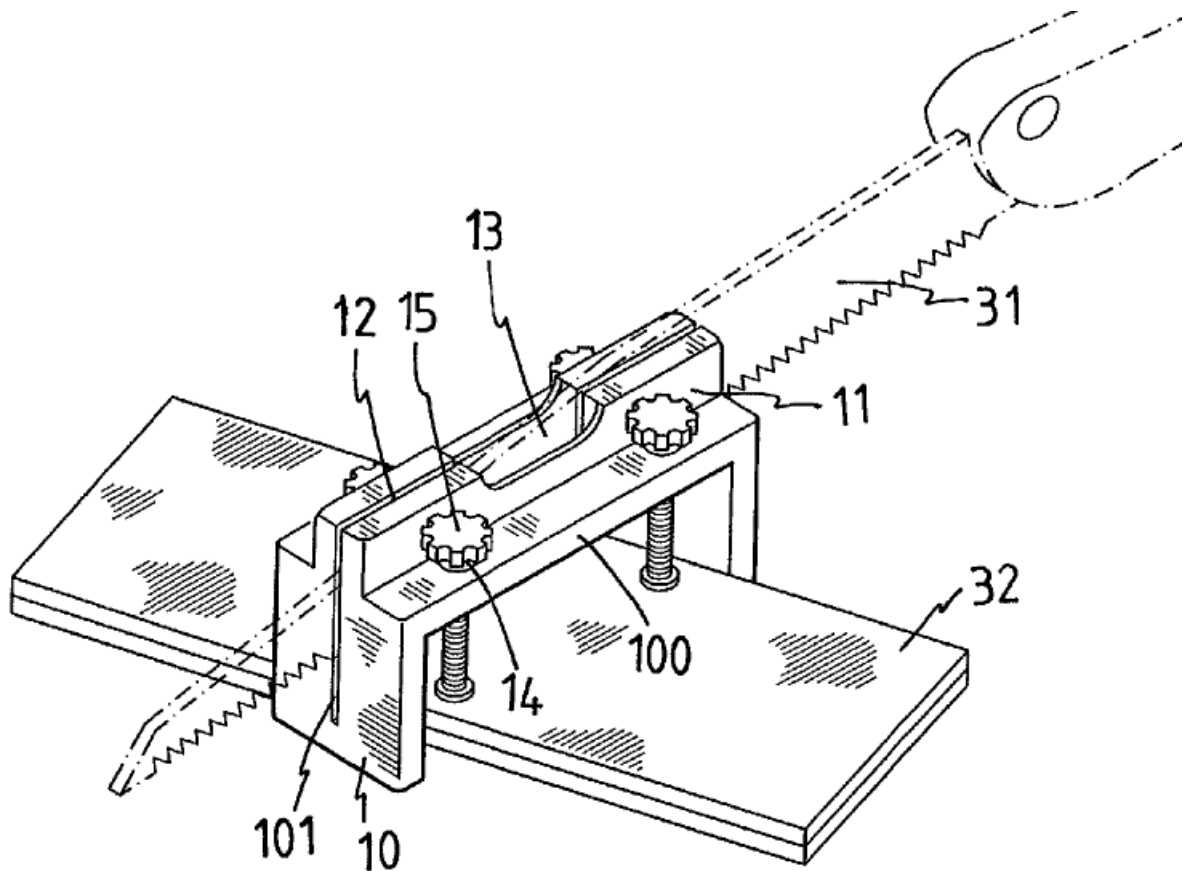

**B23D 51/027**

{with adjustment of a space between the guide surfaces}

**Definition statement**

*This place covers:*

Adjustment providing a wider or narrower space for the blade, or for part of the tool that moves with the blade, or for the workpiece.

**B23D 51/028**

{with adjustment of the guide surfaces by rotation about an axis parallel to the work support surface}

**Definition statement**

*This place covers:*

Illustrative example of subject matter classified in this place:

Note, in the figure below, the horizontal pivot axis.

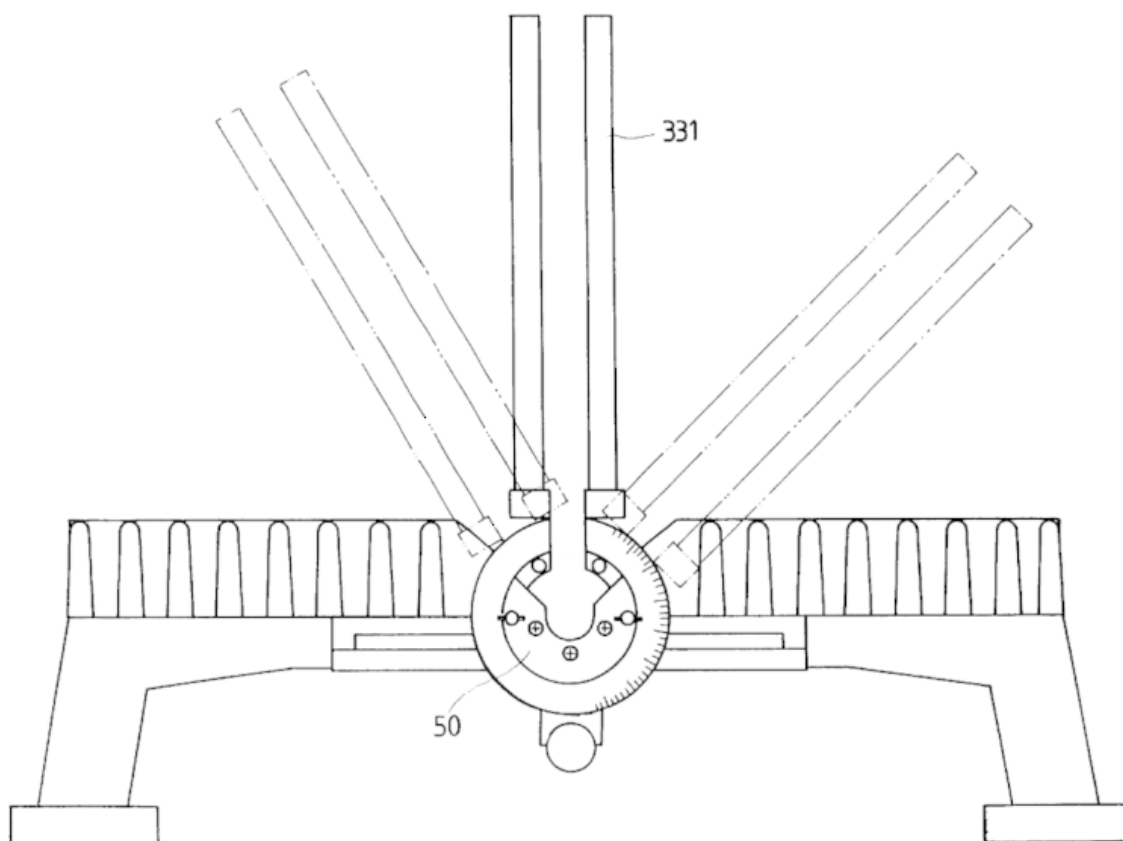



**B23D 51/029**

{with adjustment of the guide surfaces by rotation about an axis perpendicular to the work support surface}

**Definition statement**

*This place covers:*

Illustrative example of subject matter classified in this place:

Note, in the figure below, the vertical pivot axis.

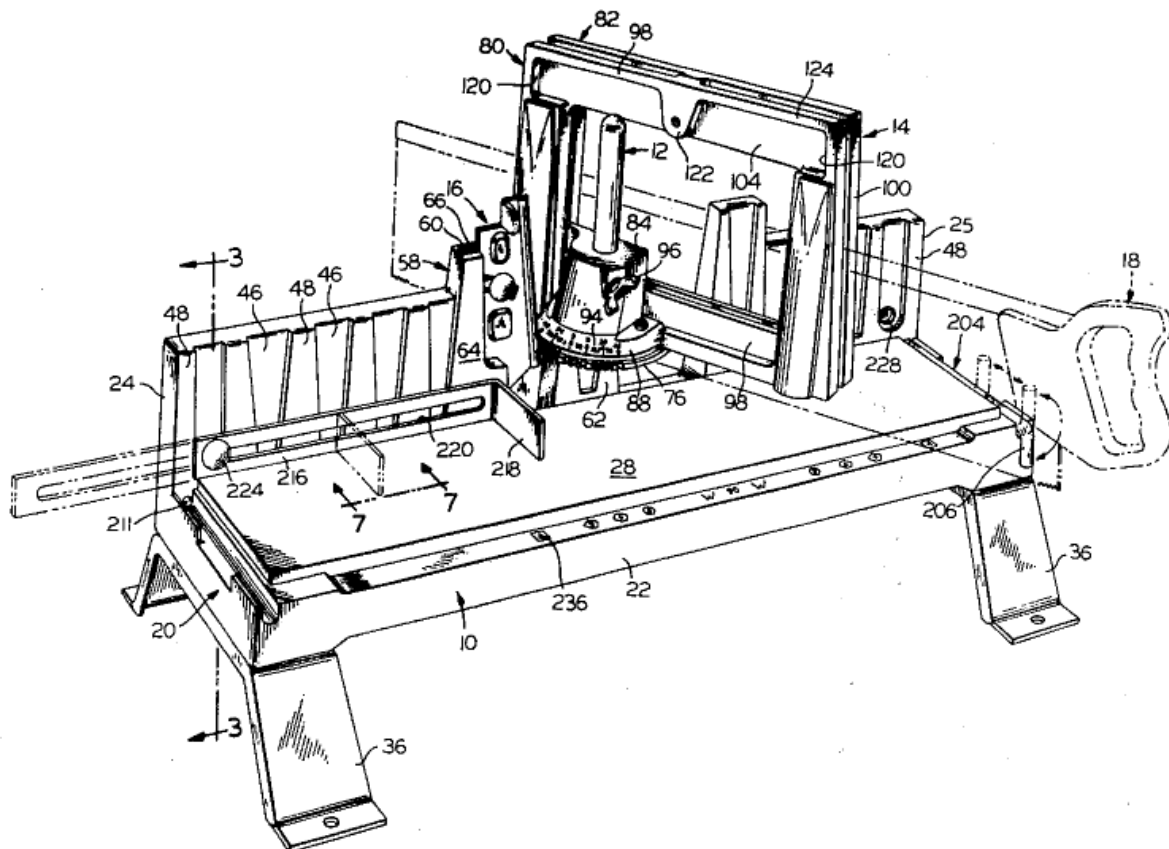
**B23D 51/161**

{with dynamic balancing}

**Definition statement**

*This place covers:*

Devices provided with a counterbalancing means to negate or neutralize the kinetic effect of the tool.

## **B23D 51/1615**

**{with shock absorbing means}**

### **Definition statement**

*This place covers:*

Devices provided with dampers, springs or similar mechanisms to dissipate, or render less harmful, the vibrations or "jars" caused by the to-and-fro movements of the tool. These mechanisms could be in the drive train, the housing, the handle or elsewhere.

## **B23D 51/162**

**{Stored energy furnished drive in one direction}**

### **Definition statement**

*This place covers:*

Devices having means which capture energy to move or assist in moving the tool in the opposite direction of the tool movement.

Illustrative example of subject matter classified in this place:

The energy storing mechanism is shown as a spring (5) in the figure below.

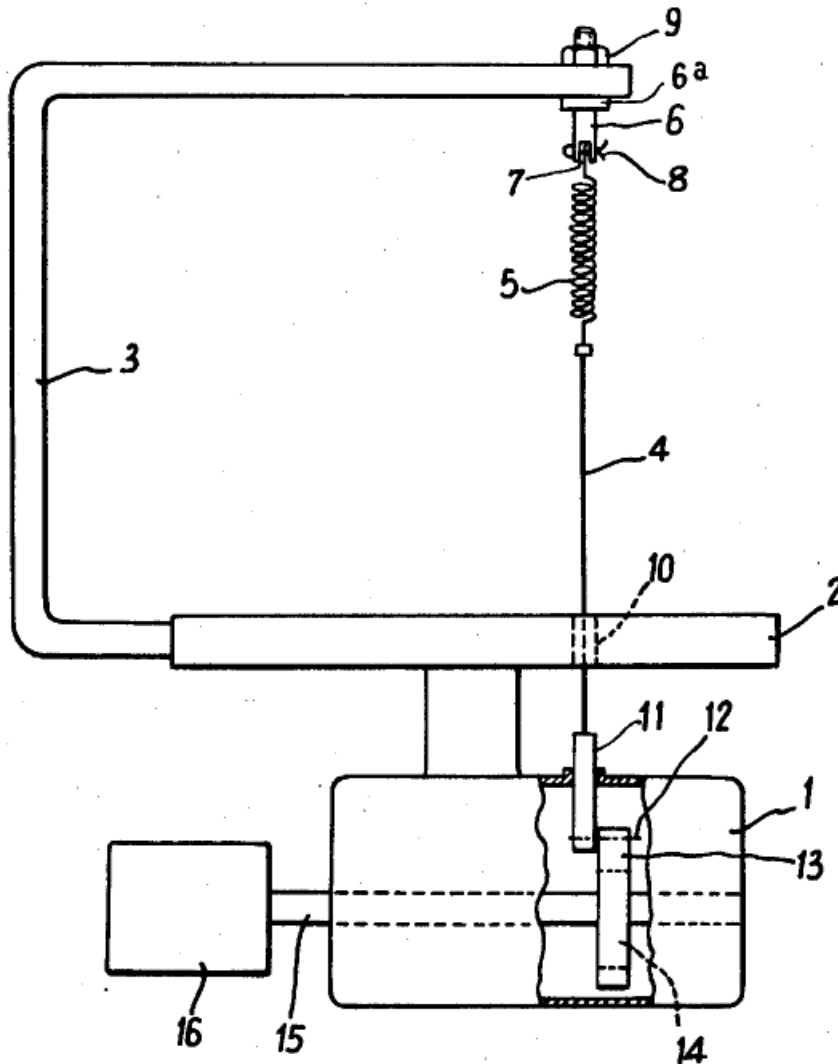

### B23D 53/00

Machines or devices for sawing with strap saw-blades which are effectively endless in use, e.g. for contour cutting

#### References

##### Limiting references

*This place does not cover:*

Band or strap sawing machines specially designed for length cutting of trunks with a plurality of band saw blades	<a href="#">B27B 15/08</a>
---	----------------------------

**B23D 53/0051****{Contiguous oppositely moving saw blade portions}****Definition statement***This place covers:*

Illustrative example of subject matter classified in this place:

Note, in the figure below, how one blade section abuts another blade section, but is running in the opposite direction.

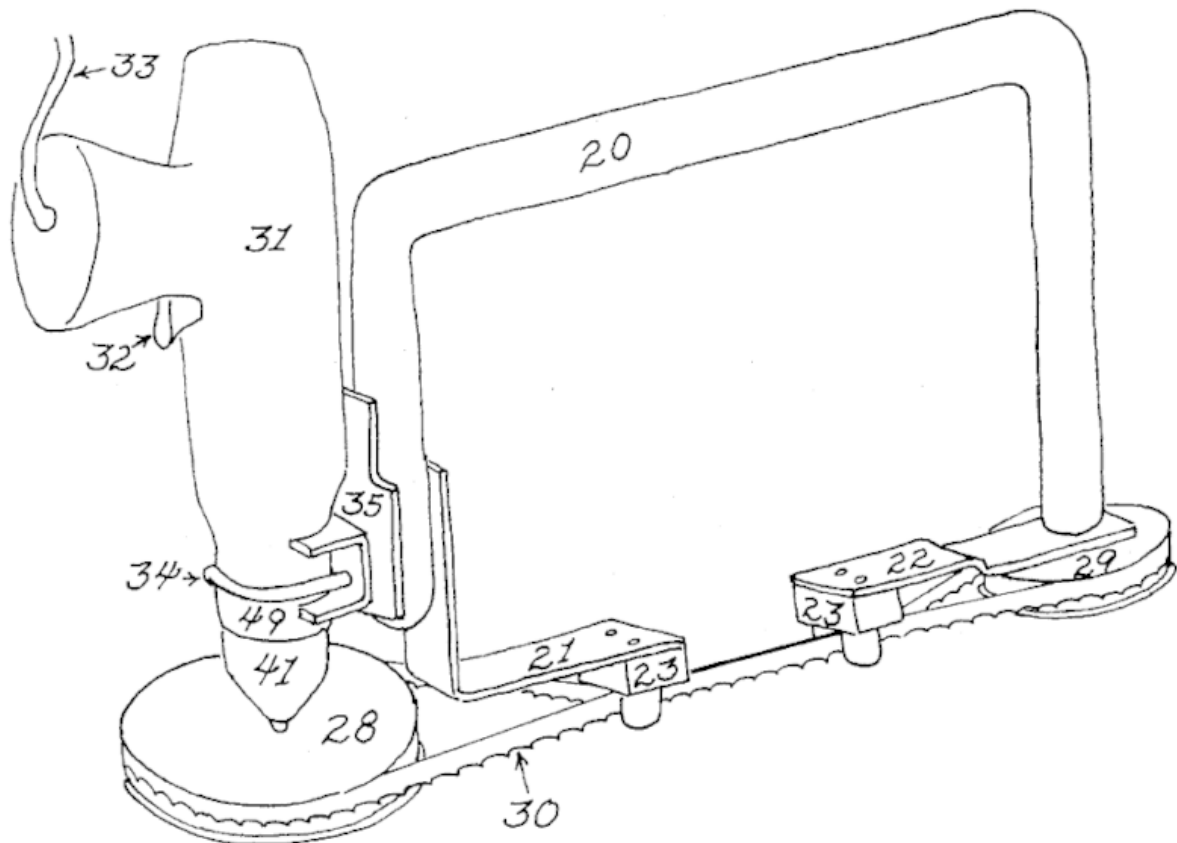
**B23D 53/0052****{with adjustment of separation between cutting zones}****Definition statement***This place covers:*

Illustrative example of subject matter classified in this place:

Note, in the figure below, how the two blades (B) can have their spacing adjusted left and right.

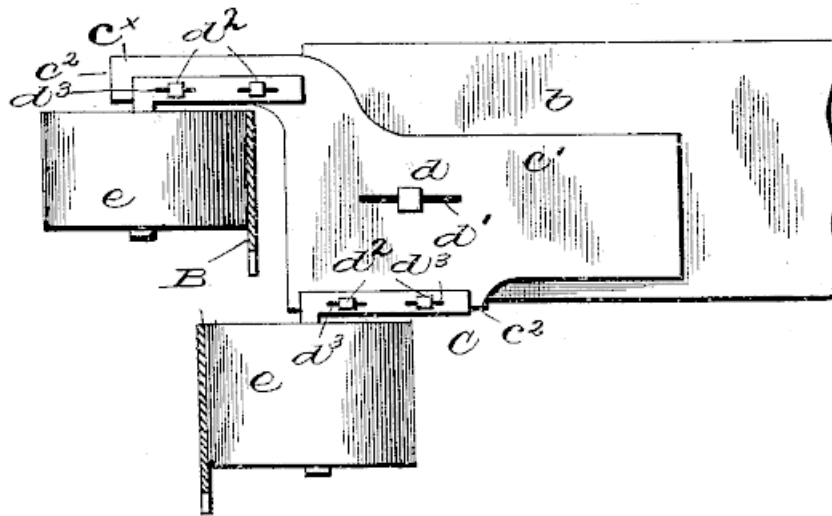

## B23D 53/0054

{by lever means}

### Definition statement

*This place covers:*

Devices wherein the space varying means is a member pivoted about a fulcrum.

Illustrative examples of subject matter classified in this place:

Note the levers (63,65).

1.

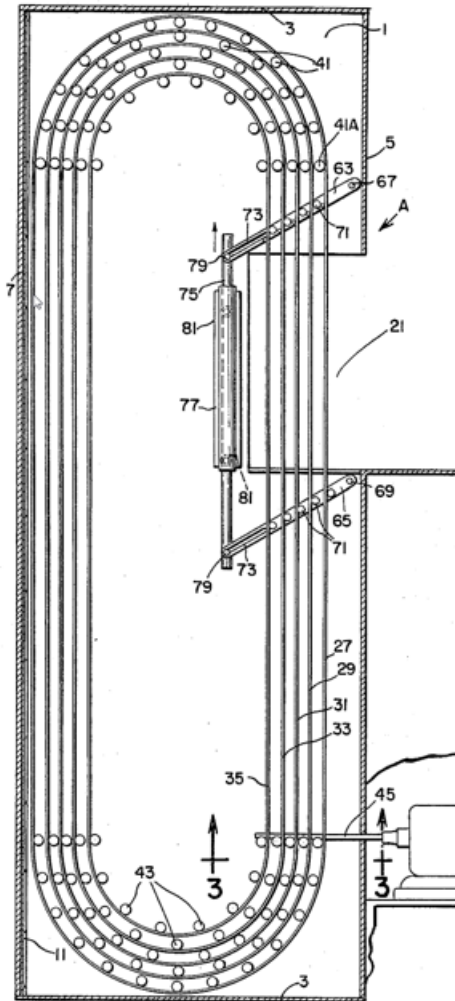

Note the scissoring levers (19).

2.

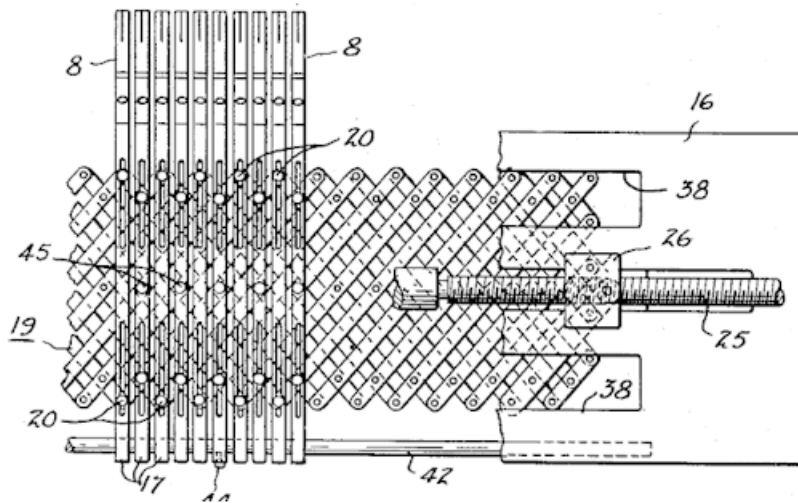

**B23D 53/0056****{by screw threaded means}****Definition statement***This place covers:*

Devices wherein the space varying means is a member having a helical rib thereon that is mated with a second member so that relative rotation between the members varies the spacing between cutting spans.

**B23D 53/0058****{including a saw blade assuming a figure 8 during use}****Definition statement***This place covers:*

Illustrative example of subject matter classified in this place:

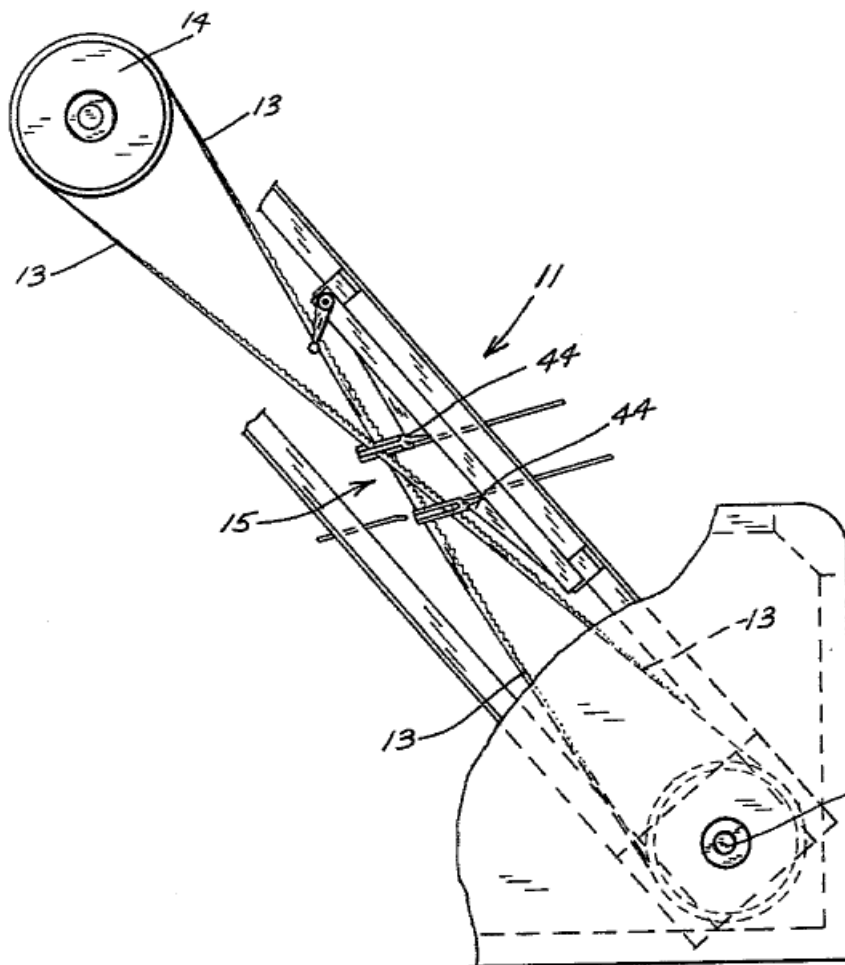

## B23D 53/028

{with adjustment of distance between band and work support surface}

### Definition statement

*This place covers:*

Devices in which the distance between the plane of the cutting span and the plane of the work support surface is changed such that the distance between the cutting span and the work support surface is varied while maintaining the orientation between the cutting span and the support surface.

Illustrative example of subject matter classified in this place:

Note, in the figure below, the positional change shown in phantom.

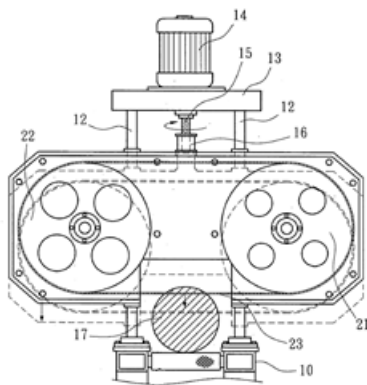

## B23D 53/049

{Angularly adjustable to cut work at a plurality of different angles}

### Definition statement

*This place covers:*

Angularly adjustable band saw blades which in addition to pivoting or shifting during sawing, the band saw can also pivot to adjust the angle of the cut.

Illustrative example of subject matter classified in this place:



Note, in the below figure, how the blade (21) can change angles relative to workpiece (W).

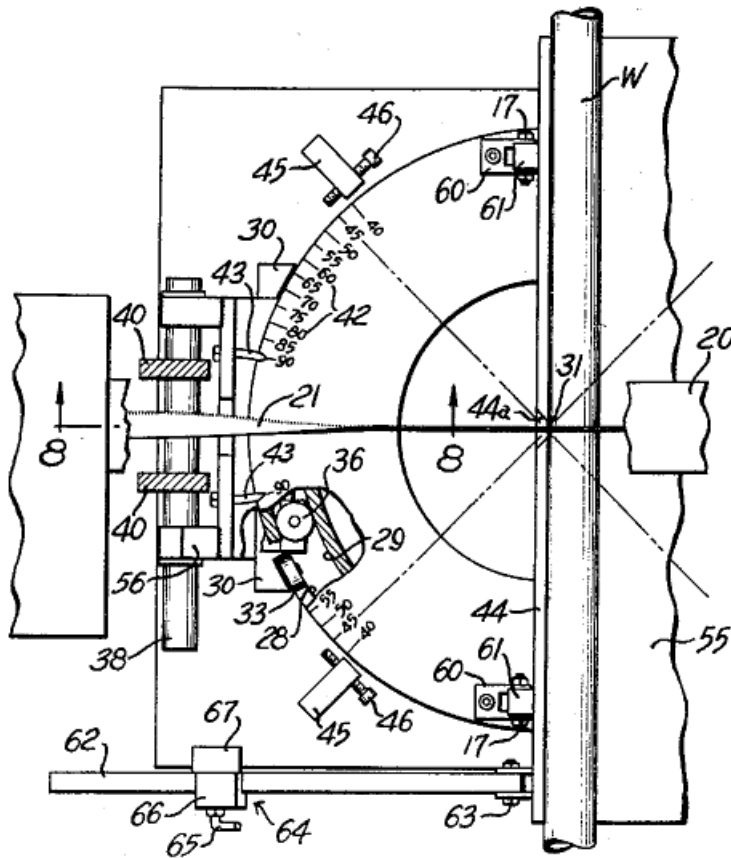

## B23D 55/00

Sawing machines or sawing devices working with strap saw blades, characterised only by constructional features of particular parts (constructional features of these parts per se [B23Q](#))

### References

#### Informative references

Attention is drawn to the following places, which may be of interest for search:

Constructional features of a shiftable or swinging work-table	<a href="#">B23D 53/06</a>
Strap saw blades, for example with incorporated tensioning devices	<a href="#">B23D 61/12</a>
Constructional features of particular parts per se	<a href="#">B23Q</a>
Guide fences	<a href="#">B27B 27/00</a>

### Special rules of classification

Reference [B23Q](#) is non-limiting in the main group [B23D 55/00](#). CPC will be updated/corrected once this inconsistency is resolved in IPC.

**B23D 55/089****{with fluid regulating means for in-feed}****Definition statement***This place covers:*

Illustrative example of subject matter classified in this place:

Note, in the figure below, where a hydraulic and pneumatic cylinder control the advancement of the blade through the workpiece.

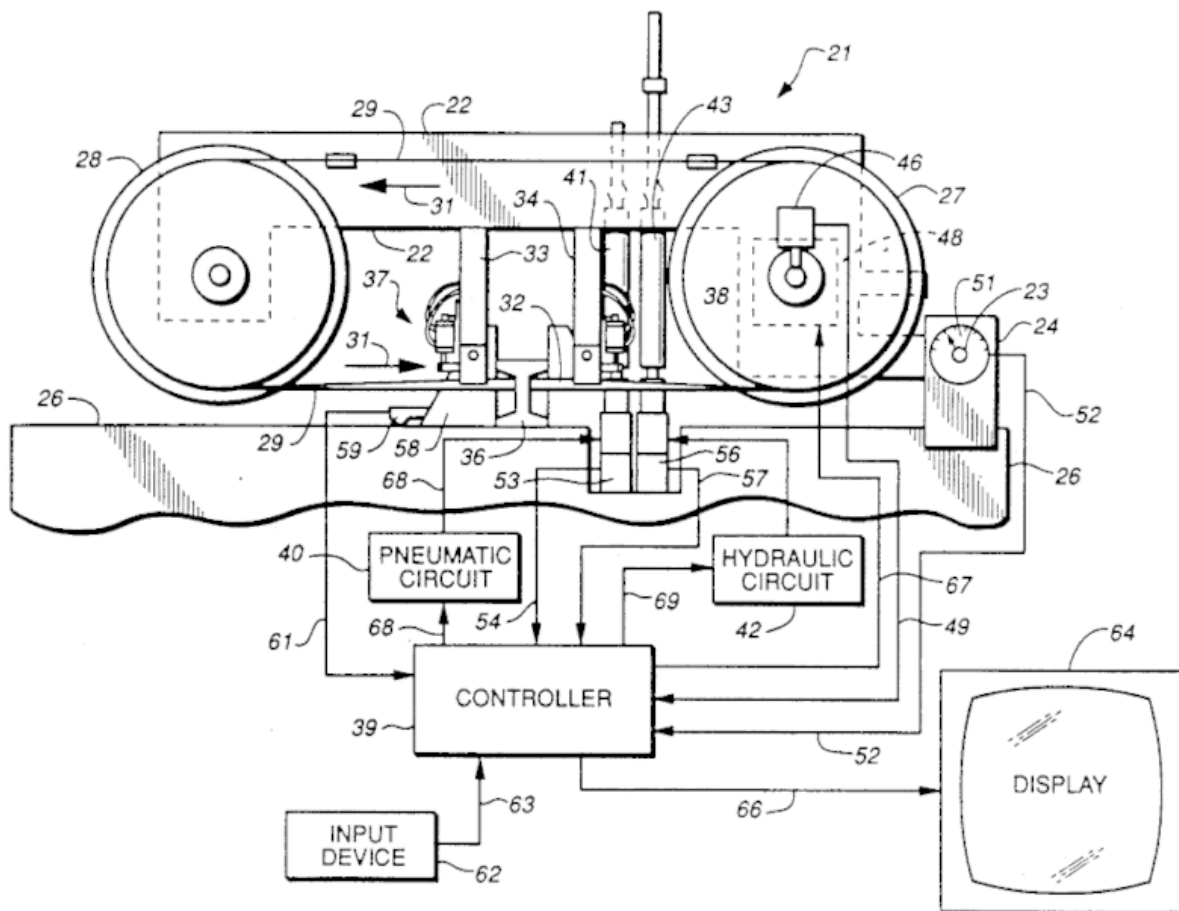
**B23D 55/102****{with means to vary the distance between pulley or sprocket axes}****Definition statement***This place covers:*

Illustrative examples of subject matter classified in this place:

Note, in figure 1 below, a cam (252) is used to change the distance between one pulley and the other.

1.

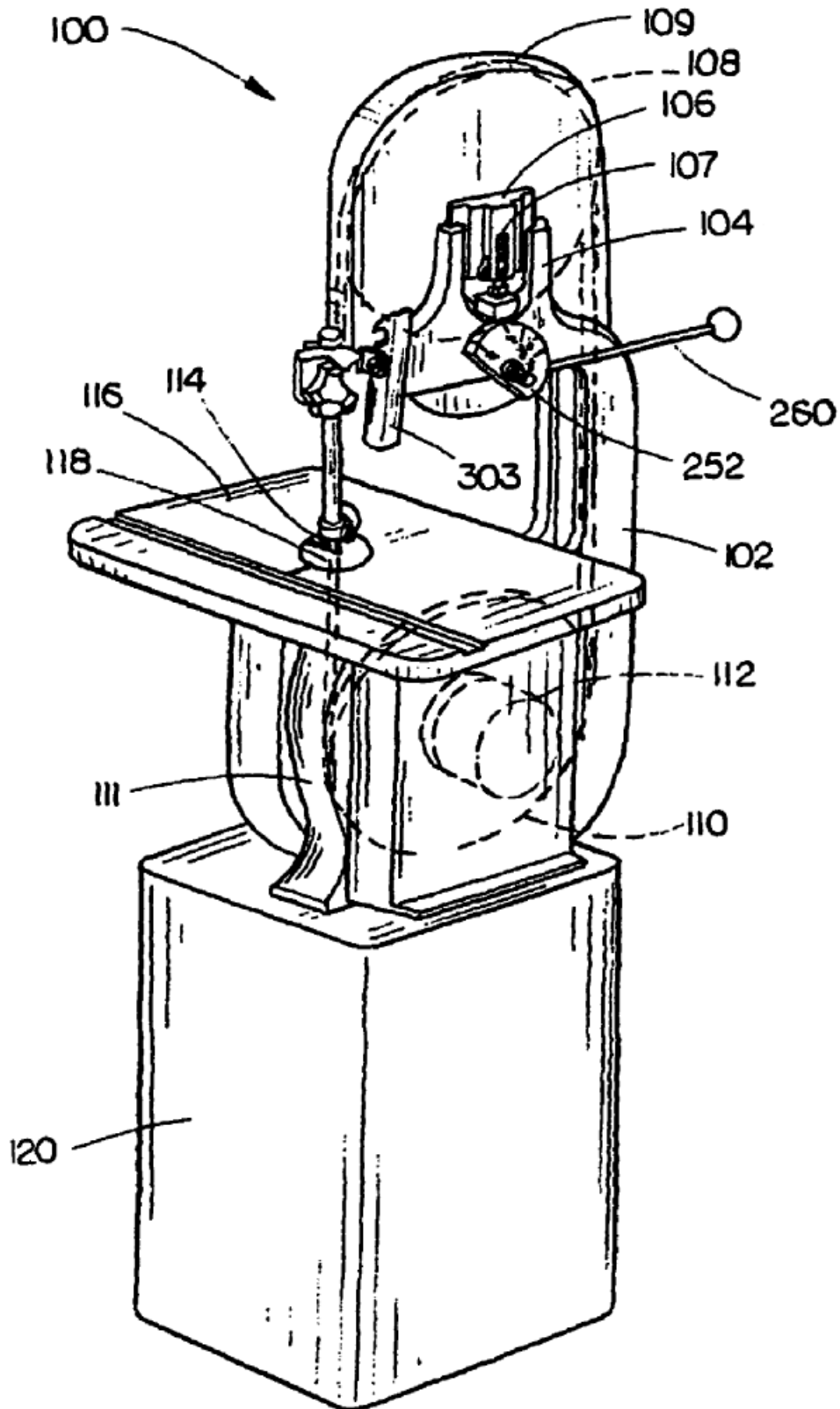

Note, in figure 2 below, a screw adjustment (10) for adjusting the distance between the pulleys.

2.

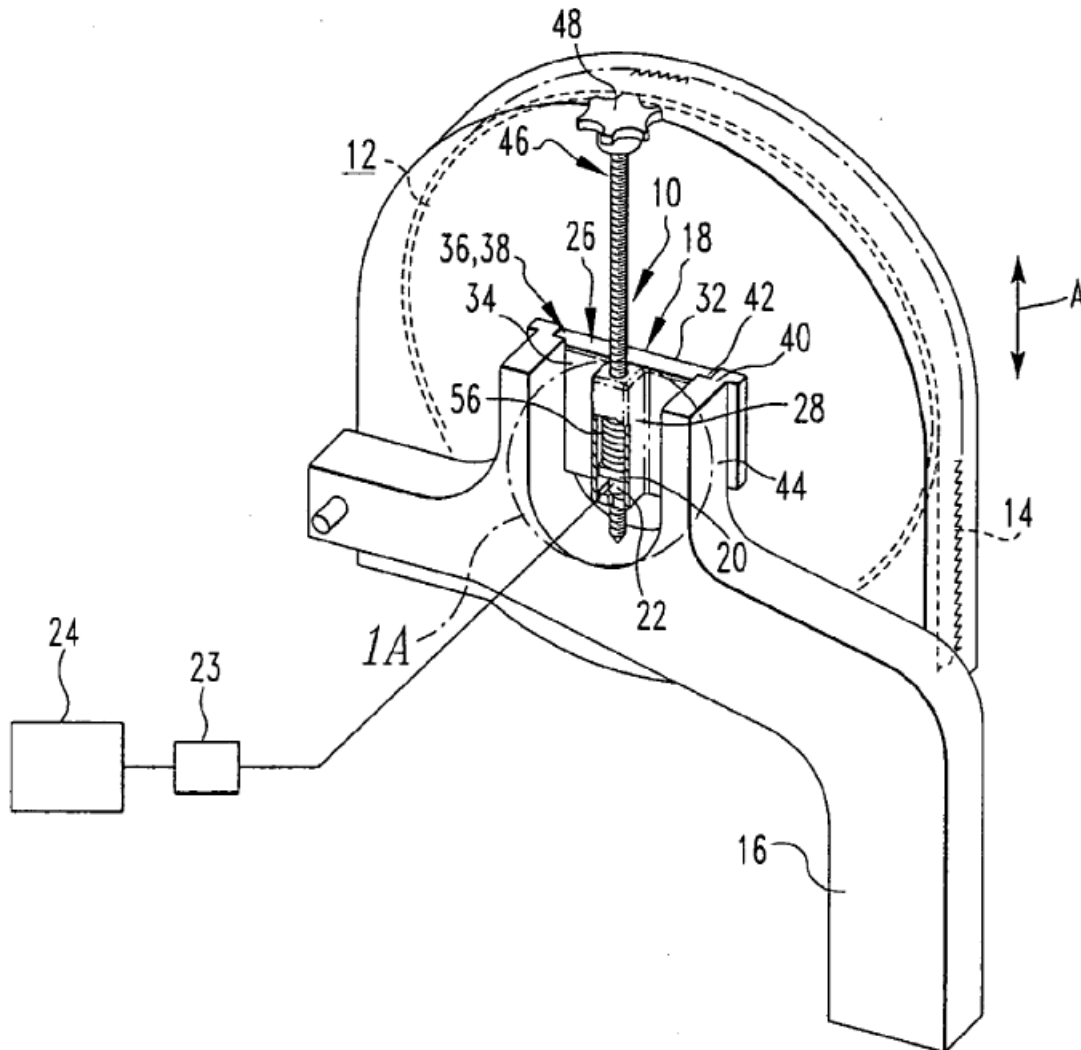

## B23D 55/104

{including means to yieldably bias at least one pulley or sprocket}

### Definition statement

*This place covers:*

Yieldable biasing means, e.g. hydraulics, counterweights, springs.

Illustrative example of subject matter classified in this place:

Note the spring (60) in the figure below.

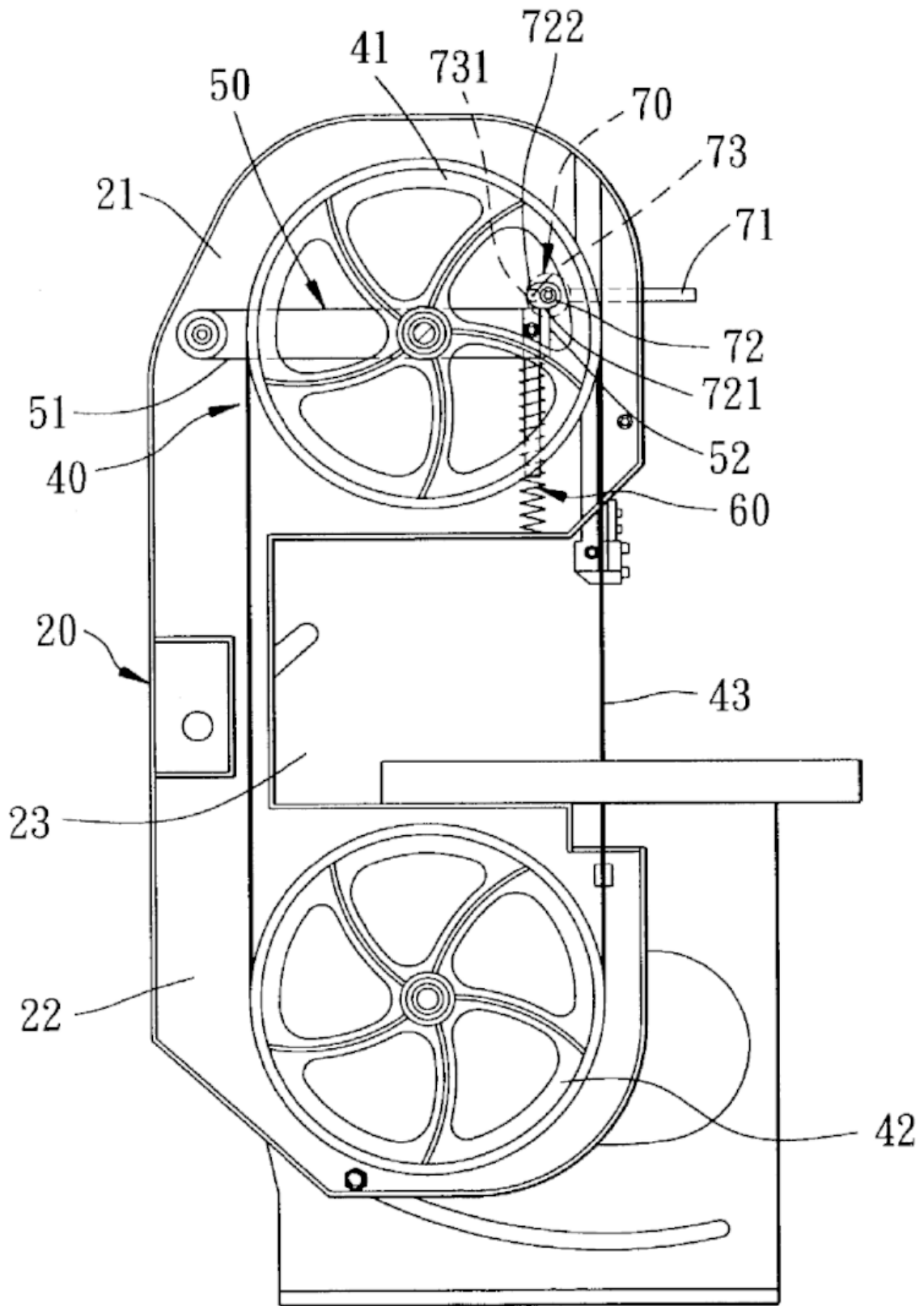

**B23D 55/122**

{of devices for changing angular relationship between pulley or sprocket axes}

**Definition statement**

*This place covers:*

Illustrative example of subject matter classified in this place:

Note the angle changes (2,4) in the figure below.

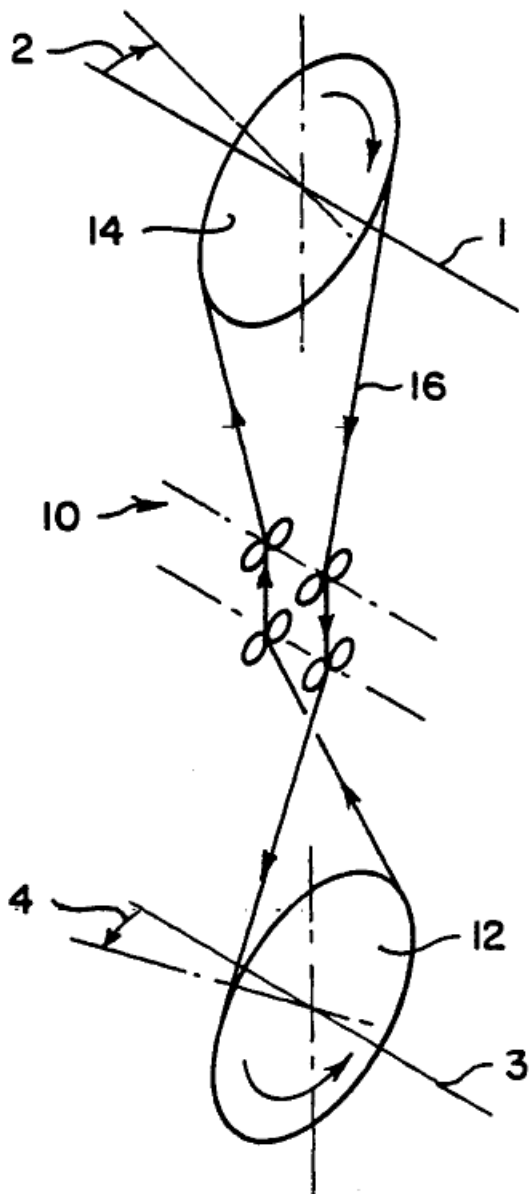

**B23D 57/00**

**Sawing machines or sawing devices not covered by one of the preceding groups [B23D 45/00](#) - [B23D 55/00](#)**

**Definition statement**

*This place covers:*

For example: wire saws, chain saws, saws for sawing under water or at places accessible with difficulty.

**References****Limiting references**

*This place does not cover:*

Saw wires	<a href="#">B23D 61/185</a>
Constructional features of particular parts per se	<a href="#">B23Q</a>
Details of chain saws, equipment for chain saws	<a href="#">B27B 17/00</a>
Saw chains	<a href="#">B27B 33/14</a> , <a href="#">B28D 1/124</a>

**Informative references**

*Attention is drawn to the following places, which may be of interest for search:*

Grinders for cutting-off using a cutting wire	<a href="#">B24B 27/0633</a>
---	------------------------------

**B23D 59/00**

**Accessories specially designed for sawing machines or sawing devices (lubricating or cooling machine tools in general [B23Q 11/12](#))**

**References****Limiting references**

*This place does not cover:*

Devices for removing chips for machine tools in general	<a href="#">B23Q 11/0042</a>
Lubricating or cooling machine tools in general	<a href="#">B23Q 11/12</a>
Mounting for swivelling or tilting a circular saw blade	<a href="#">B27B 5/36</a>
Arrangements for adjusting the cutting depth or the amount of tilting of portable power-driven circular saws for manual operation	<a href="#">B27B 9/02</a>
Guide fences	<a href="#">B27B 27/00</a>
Measuring in general	<a href="#">G01</a>
Controlling in general	<a href="#">G05</a>

**B23D 59/0062****{by blowing}****Definition statement***This place covers:*

Illustrative example of subject matter classified in this place:

Note, in the figure below, the tubes (33,34) that blow air against the sawdust.

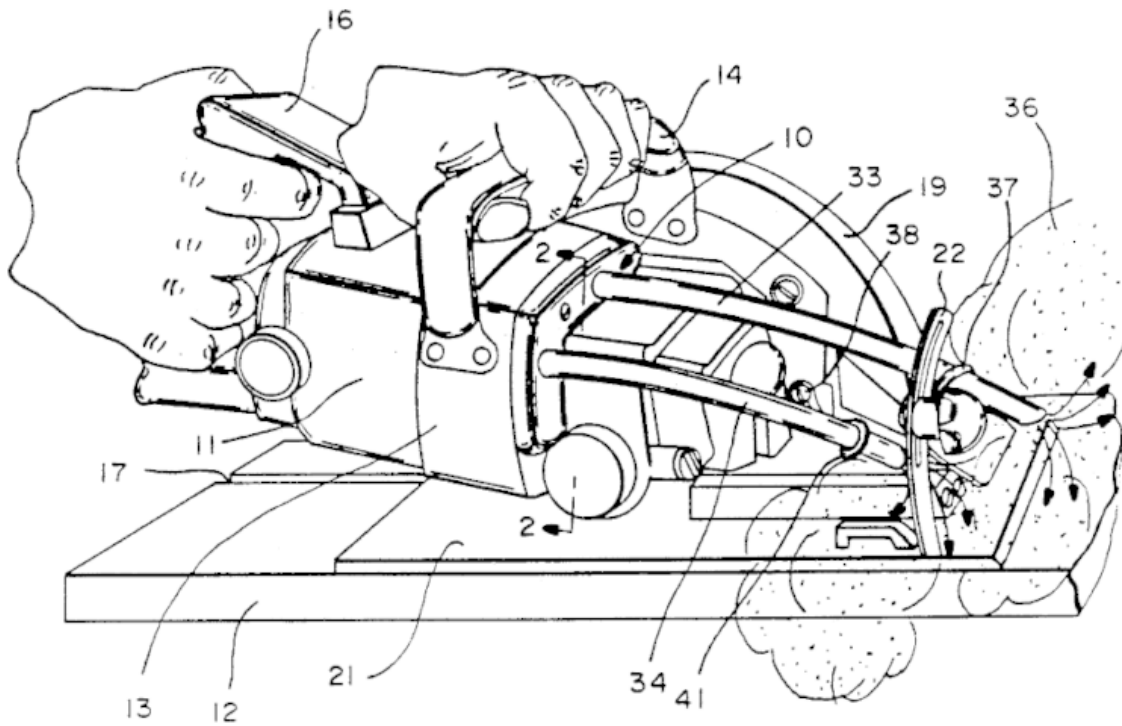
**B23D 59/0064****{by suction}****Definition statement***This place covers:*

Illustrative example of subject matter classified in this place:



Note, in the figure below, the tube (20) that sucks the sawdust away from the saw.

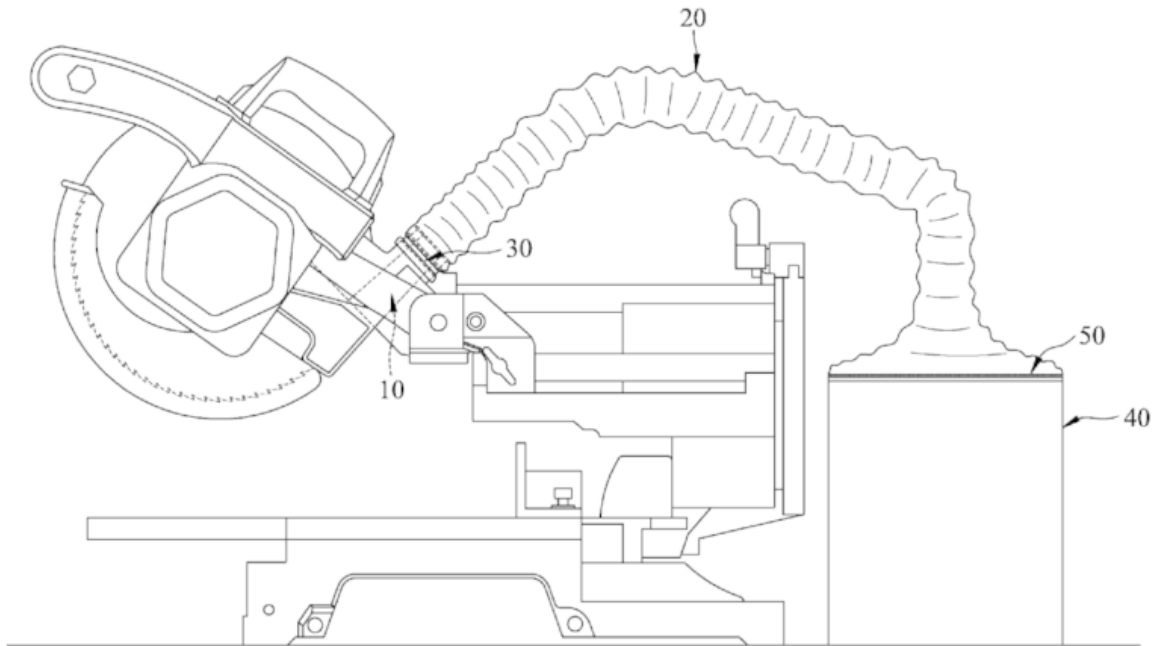

## **B23D 61/00**

**Tools for sawing machines or sawing devices (tools for trepanning [B23B 51/04](#)); Clamping devices for these tools**

### **References**

#### **Limiting references**

*This place does not cover:*

Devices for mounting straight saw blades or other tools	<a href="#">B23D 51/08</a>
Tools for trepanning	<a href="#">B23B 51/04</a>
Cut-off wheels of bonded abrasive or with inserted abrasive blocks	<a href="#">B24D 5/12</a>
Mounting or securing circular saw blades or saw spindles	<a href="#">B27B 5/30</a> - <a href="#">B27B 5/36</a>
Saw chains	<a href="#">B27B 33/14</a> , <a href="#">B28D 1/124</a>

#### **Informative references**

*Attention is drawn to the following places, which may be of interest for search:*

Grinders for cutting-off using a cutting wire	<a href="#">B24B 27/0633</a>
---	------------------------------

## **B23D 61/0212**

**{Varying pitch}**

### **Definition statement**

*This place covers:*

Saw blades where the distance between teeth varies in the direction of travel.

Illustrative example of subject matter classified in this place:

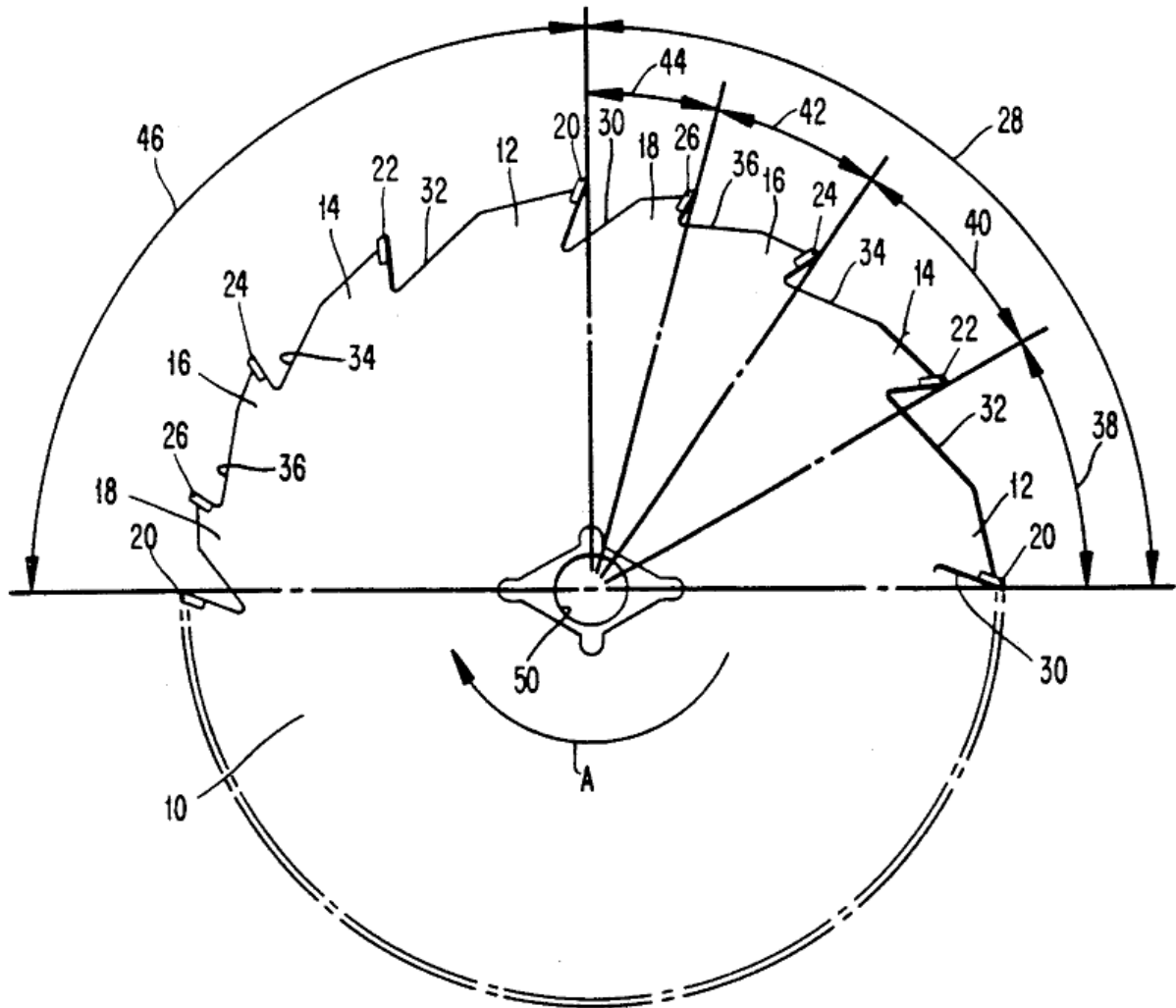

## B23D 61/0214

{Varying tooth height}

### Definition statement

*This place covers:*

Saw blades where the distance from a tooth tip to the center of rotation varies from one tooth to another tooth.

Illustrative example of subject matter classified in this place:

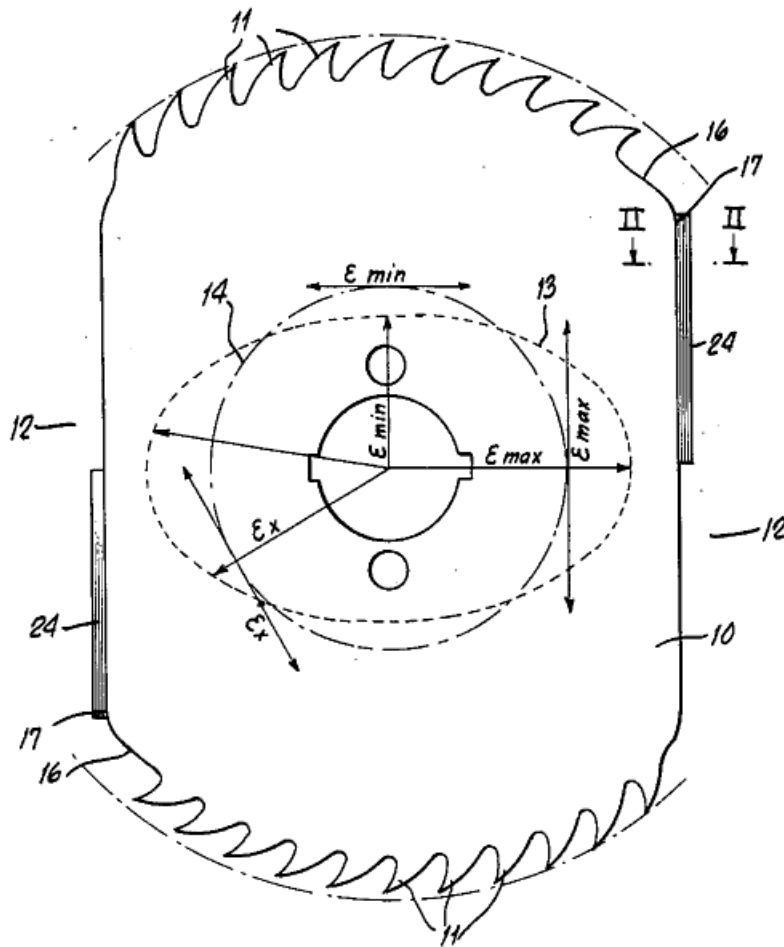

## B23D 61/022

{with depth limiter on the saw blade}

### Definition statement

*This place covers:*

Saw blades having a depth limiter that prevents the cutting tooth from penetrating further into the workpiece.

Illustrative example of subject matter classified in this place:

Note, in the figure below, element (24) acts as a depth limiter.

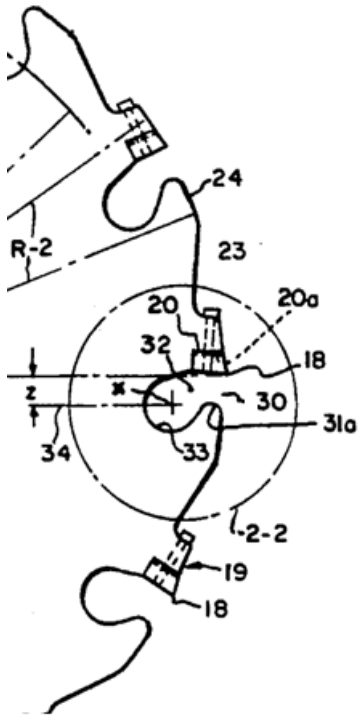

## **B23D 61/0225**

**{with teeth having transversely curved cutting edges}**

### **Definition statement**

*This place covers:*

Illustrative examples of subject matter classified in this place:

Note, in the figures below (Fig. 1a and 1b), the cutting edge (9' in Fig. 1b) is curved in a direction transverse to the plane of the blade.

1a.

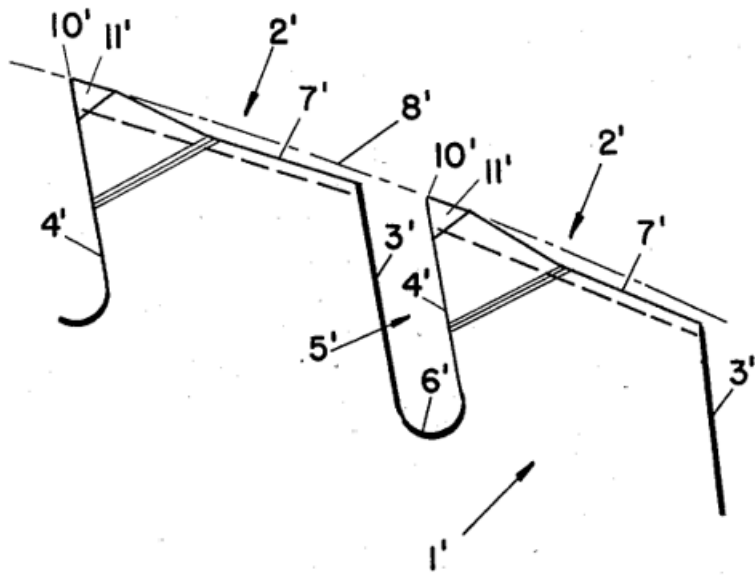

1b.

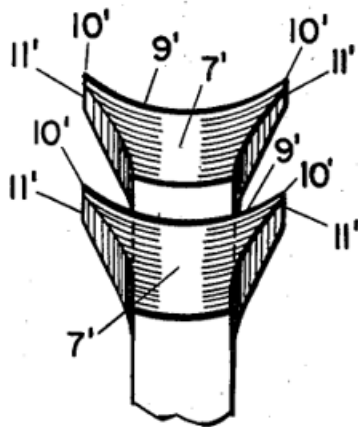

Note, in Fig. 2 below, the cutting edge (50') is curved in a direction transverse to the plane of the blade.

2.

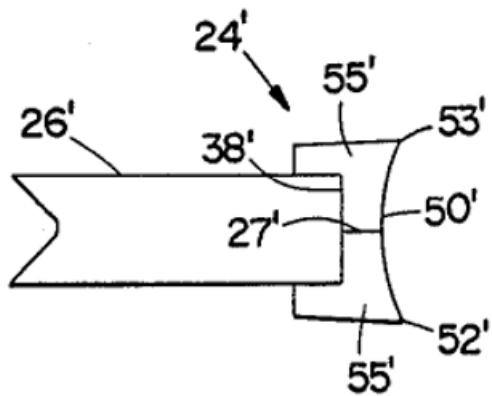

### B23D 61/027

{Element on or along a side of the saw blade for clearing or widening kerf}

#### Definition statement

*This place covers:*

Illustrative example of subject matter classified in this place:

Note elements (4) in the figure below.

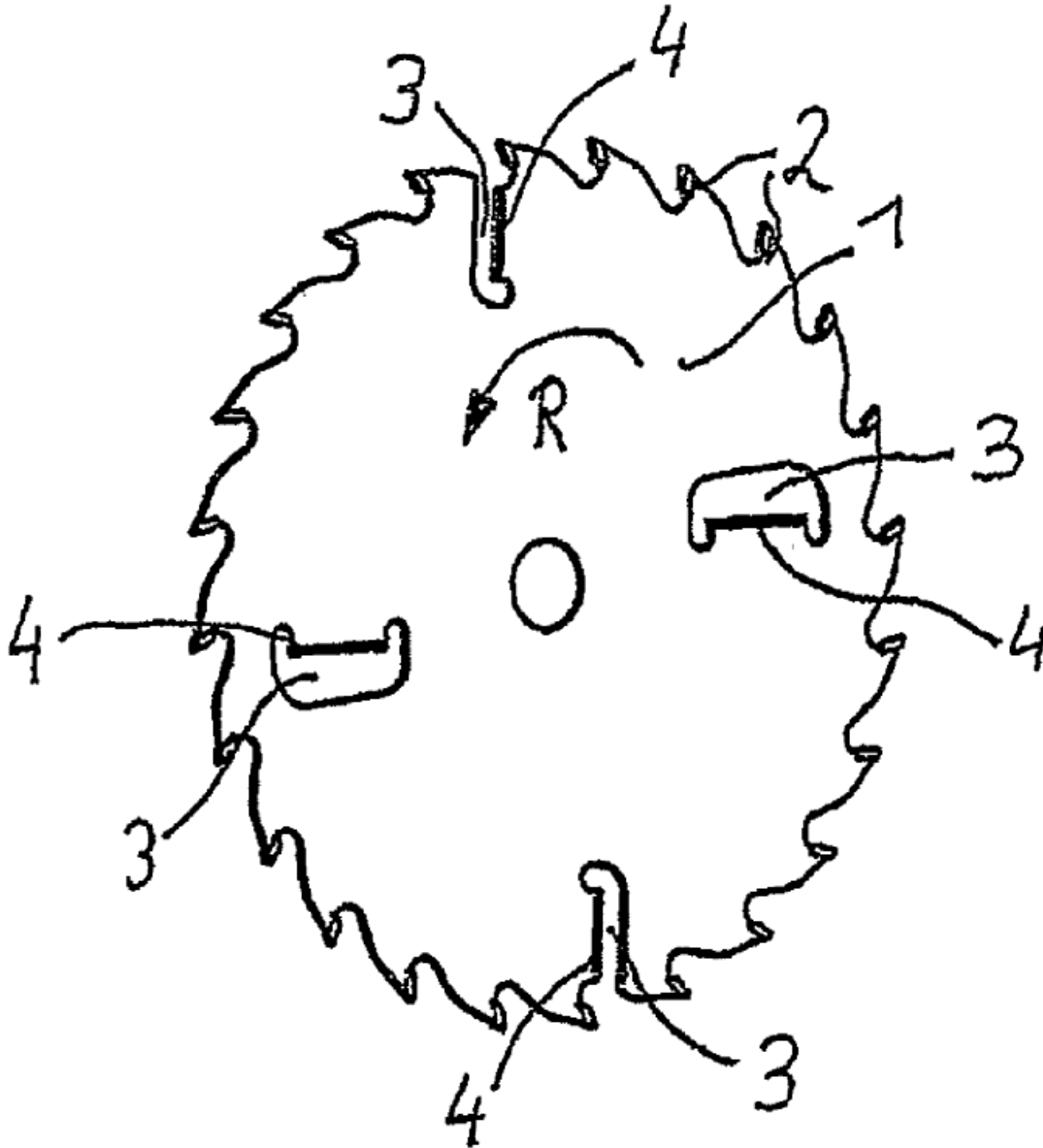

**B23D 61/0275**

{Slots in the saw blade body for reducing tension or vibration}

**Definition statement**

*This place covers:*

Slots on the saw blade body for reducing tension or vibration. The slots could extend to the periphery.

Illustrative example of subject matter classified in this place:

Note slots (548, 550) in the figure below.

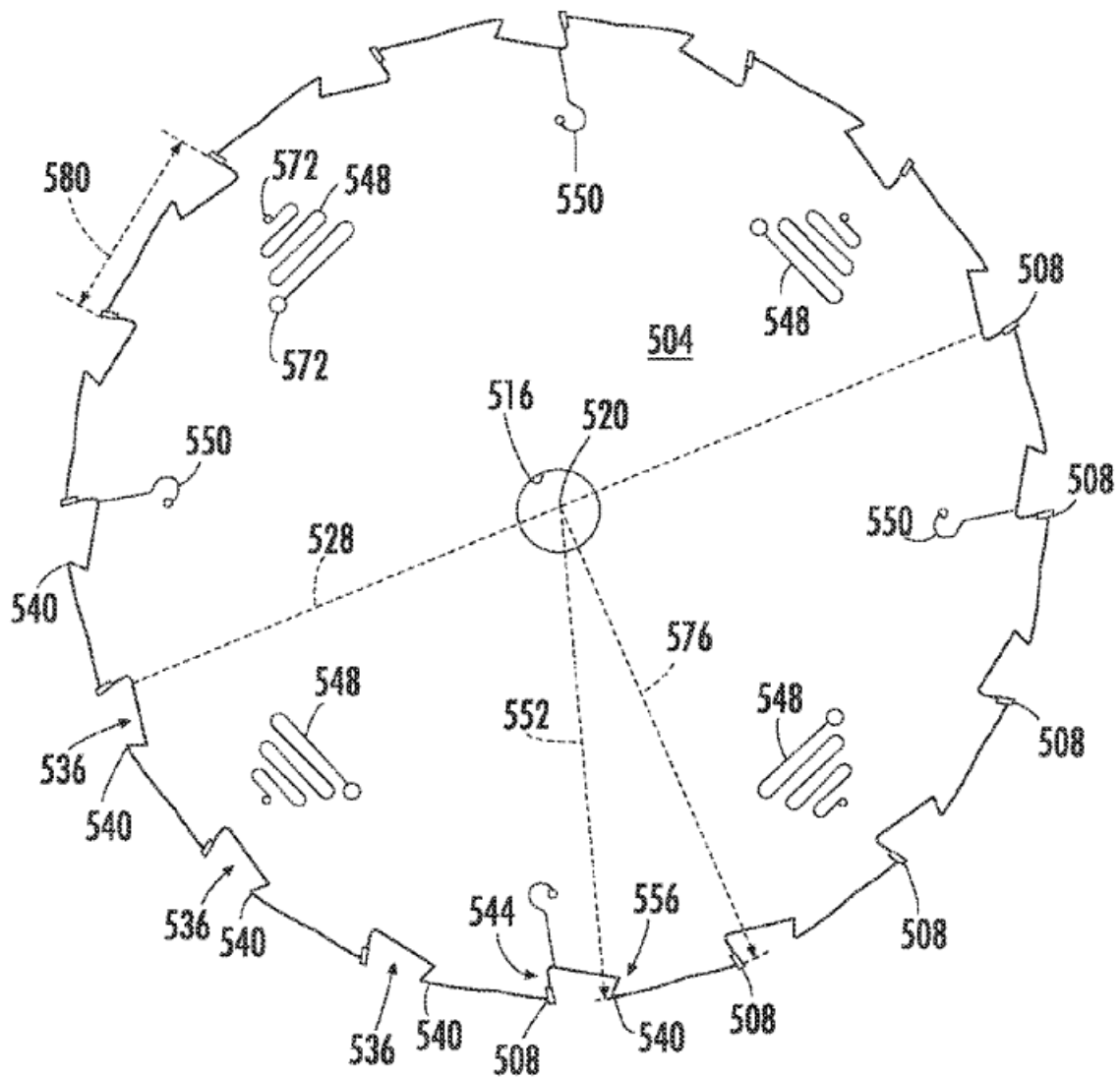

## B23D 61/071

{with teeth connected by independent connecting elements}

### Definition statement

*This place covers:*

Saw blades having at least one independent connecting element, e.g. a bolt, that is separable from the saw blade body for connecting a tooth.

Illustrative examples of subject matter classified in this place:

Note, in Fig .1 below, connecting element 12, but could be any element so long as it is separable from the saw blade body



1.

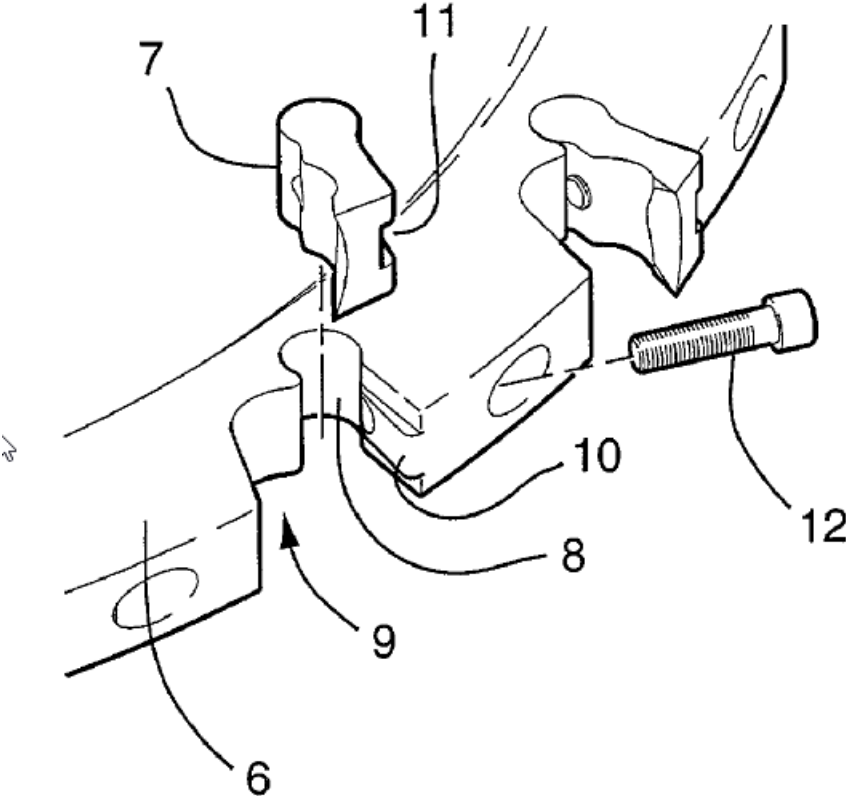

Note, in Fig. 2 below, connecting element 4.

2.

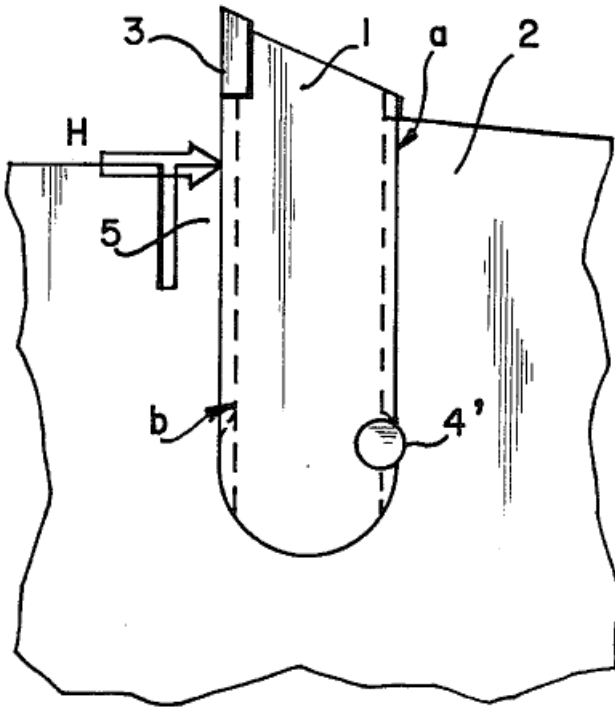

## B23D 61/075

{with teeth connected by deformation}

### Definition statement

*This place covers:*

Circular saw blades with exchangeable inserted saw teeth connected by a flexible portion that could be part of the tooth, of the blade body or of a connecting element.

Illustrative example of subject matter classified in this place:

Note flexible element 3 in the figure below.

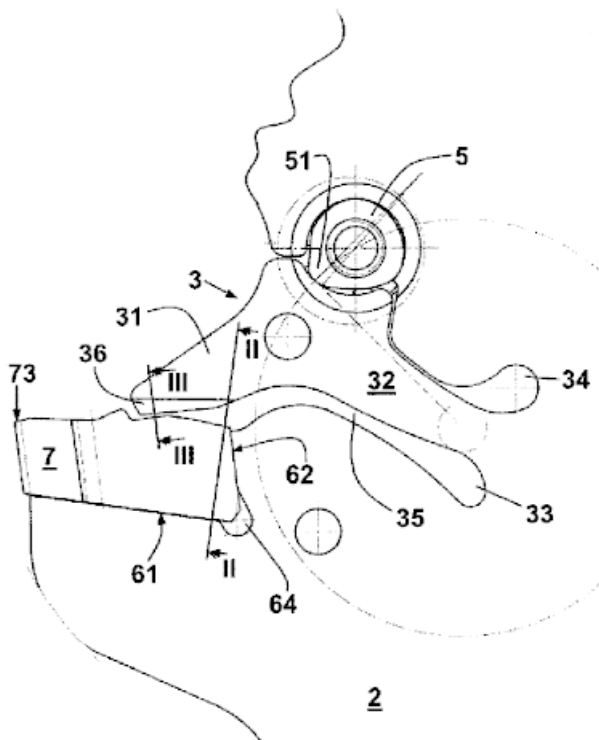

## B23D 61/1212

{Varying pitch}

### Definition statement

*This place covers:*

Saw blades where the distance between teeth varies in the direction of travel.

Illustrative example of subject matter classified in this place:

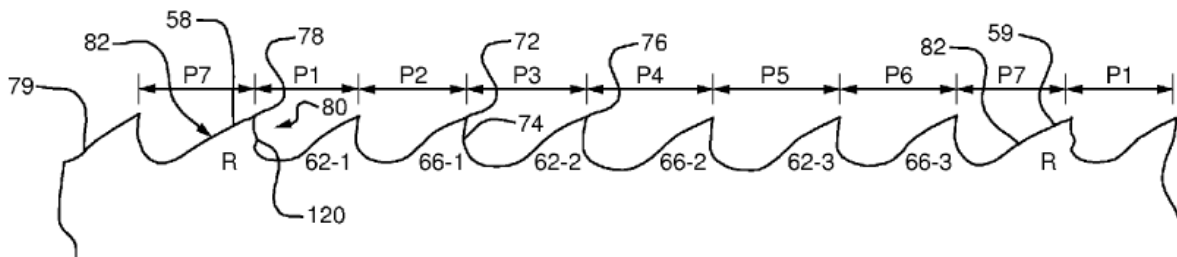

## B23D 61/1214

{Varying height}

### Definition statement

*This place covers:*

Saw blades where the height of one tooth varies from the height of another tooth.

Illustrative example of subject matter classified in this place:

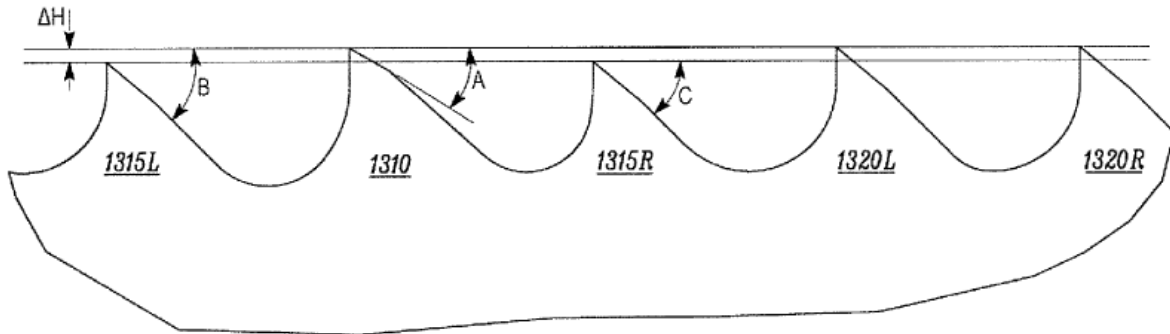

**B23D 61/1216**

{Repeating pattern of groups having three or more teeth}

**Definition statement**

*This place covers:*

Saw blades having repeating patterns of groups of teeth, where each group of teeth includes at least three teeth. Within a group of three or more teeth, there is a variance among the teeth, and the variance can include tooth width, angle, height, set or other change that affects the size or position of a cutting edge of the tooth.

Illustrative example of subject matter classified in this place:

In Fig. 1a below, note the variance between the 3 tooth angles shown in side view

1a.

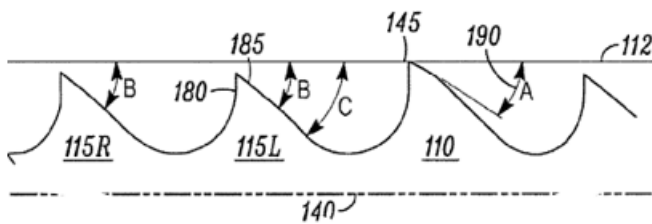

In Fig. 1b below, shown in top view of the detail of Fig. 1a, is a simple example of a repeating group of teeth with left-set, right-set, no-set.

1b.

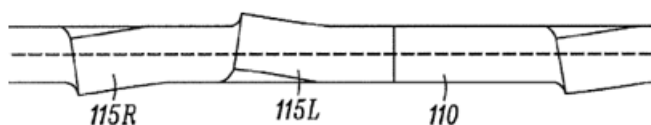

## B23D 61/1217

{Reciprocating blades having more than one section of unique teeth on one side, e.g. a fine tooth section and a large tooth section}

### Definition statement

*This place covers:*

Reciprocating blades having plurality of tooth sections that are large enough such that only one section engages the workpiece at a time.

Illustrative example of subject matter classified in this place:

Note, in the figure below, the different tooth sizes in each section in the blade.

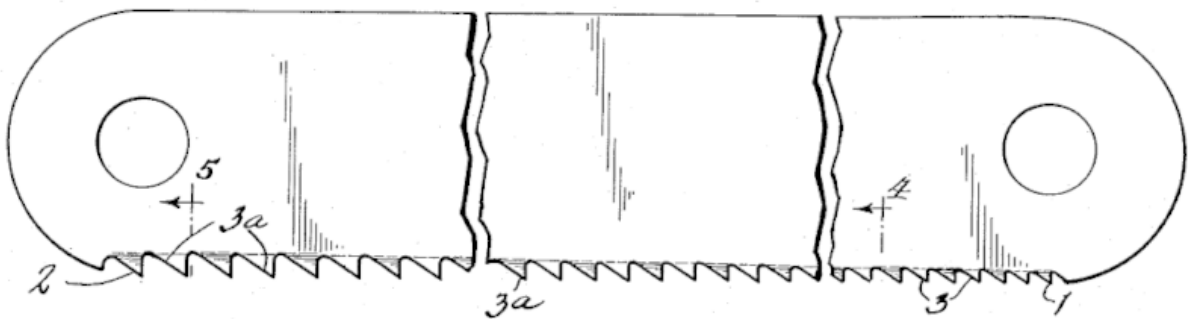

## B23D 61/1218

{with a depth limiter on the saw blade}

### Definition statement

*This place covers:*

Linear saw blades having a depth limiter that prevents the cutting tooth from penetrating further into the workpiece.

Illustrative example of subject matter classified in this place:

Note elements 21a, 21b, 21c shown in the figure below that act as depth limiters.

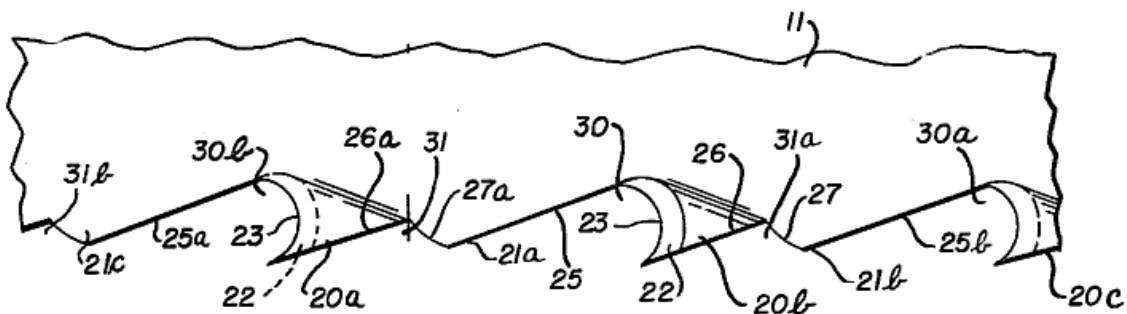

**B23D 61/1219****{with teeth having transversely curved cutting edges}****Definition statement***This place covers:*

Illustrative example of subject matter classified in this place:

Note, in the figures (1a - cross section view and 1b side view) shown below, a transversely curved cutting edge (130).

1a.

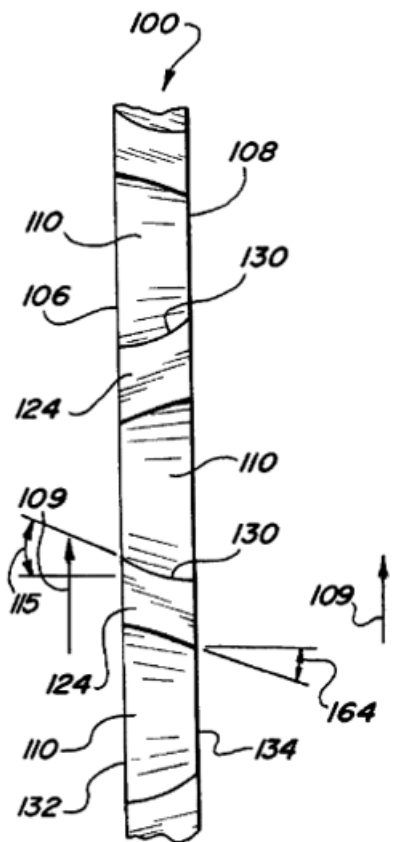

1b.

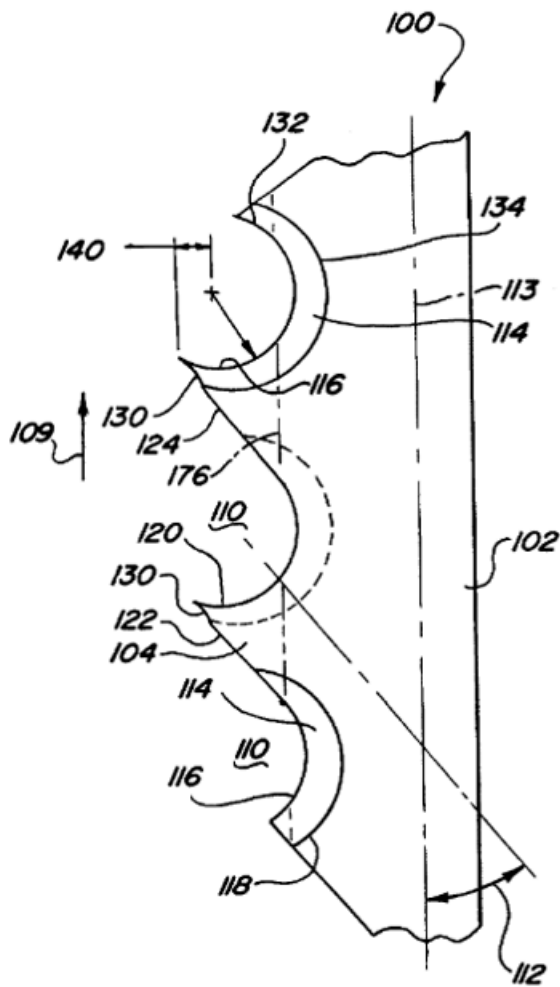

## B23D 61/124

{Element on a side of the saw blade for clearing or widening kerf}

### Definition statement

*This place covers:*

Illustrative example of subject matter classified in this place:

Note, in the figure below, elements 4.

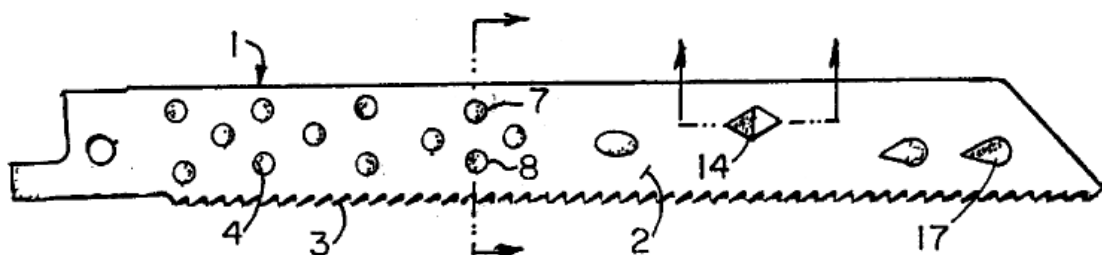

## B23D 61/1245

{Slots in the saw blade body for reducing tension or vibration}

### Definition statement

*This place covers:*

Slots on the saw blade for reducing tension or vibration. The slots can extend to the blade edge.

Illustrative example of subject matter classified in this place:

Note, in the figure below, slots 6.

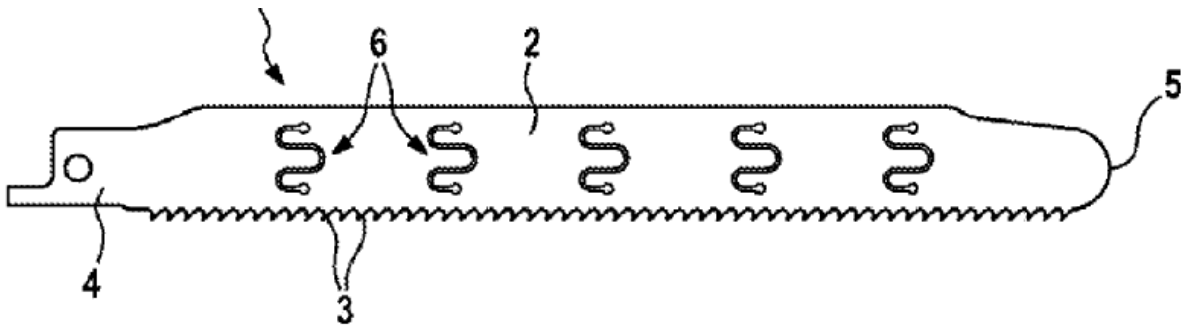

## B23D 61/1265

{Reciprocating blades with teeth on the saw nose, e.g. plunge cutters}

### Definition statement

*This place covers:*

Saw blades having noses with teeth on them that enables a user to start making a cut in the middle of a planar workpiece.

Illustrative examples of subject matter classified in this place:



1.

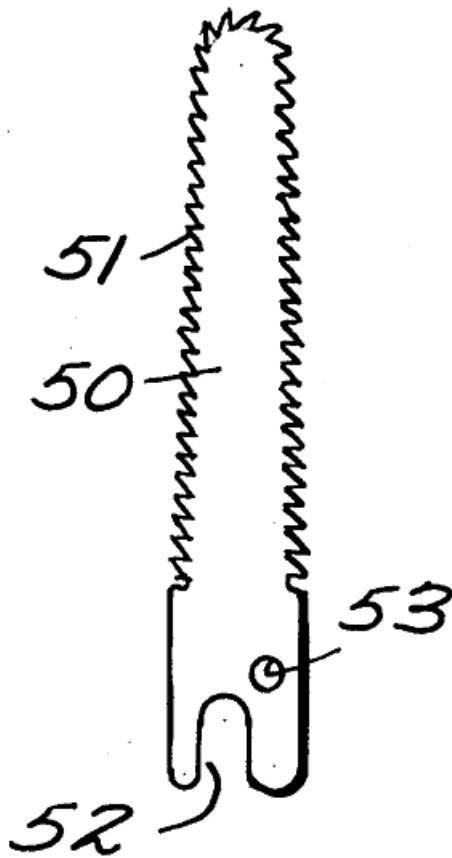

2.

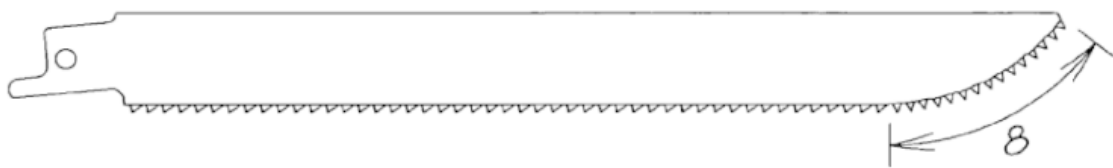

## B23D 61/171

{with teeth connected by independent connecting elements}

### Definition statement

*This place covers:*

Saw blades having exchangeable saw teeth, where the teeth are connected to the saw blade body with at least one independent connecting element. The connecting element is most often a bolt, but can be any element that is separable from the saw blade body.

Illustrative examples of subject matter classified in this place:

Note, in Fig. 1 below, connecting element 28 in Fig. 1 figure below.

1.

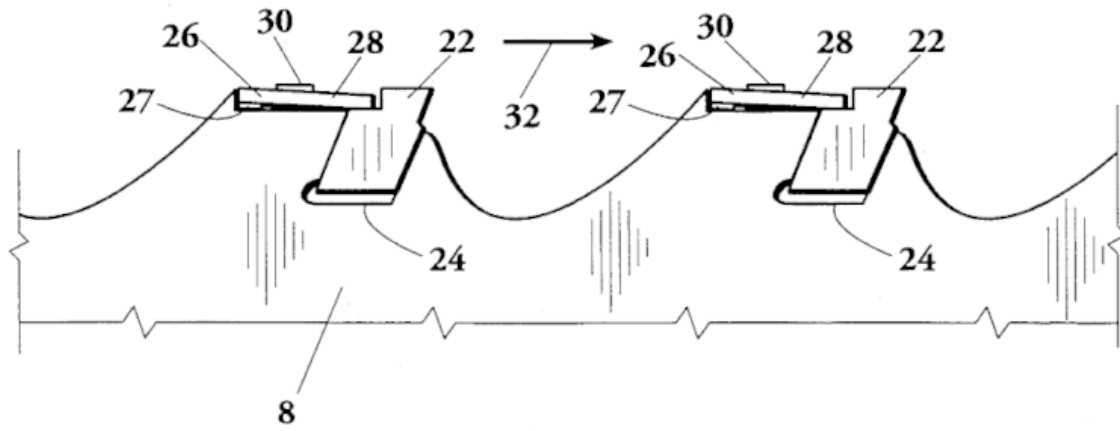

Note, in Fig. 2 below, connecting element 4'.

2.

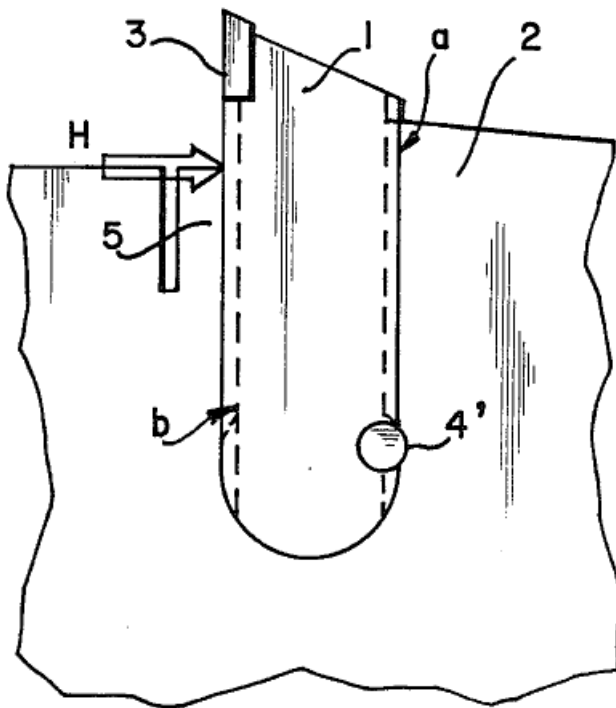

**B23D 61/175****{with teeth connected by deformation}****Definition statement***This place covers:*

Saw blades having exchangeable saw teeth, where the teeth are connected to the saw blade body by a flexible portion, where the flexible portion can be part of the tooth, part of the blade body, or part of a connecting element.

Illustrative example of subject matter classified in this place:

Note, in the figure below, element 3 is flexible.

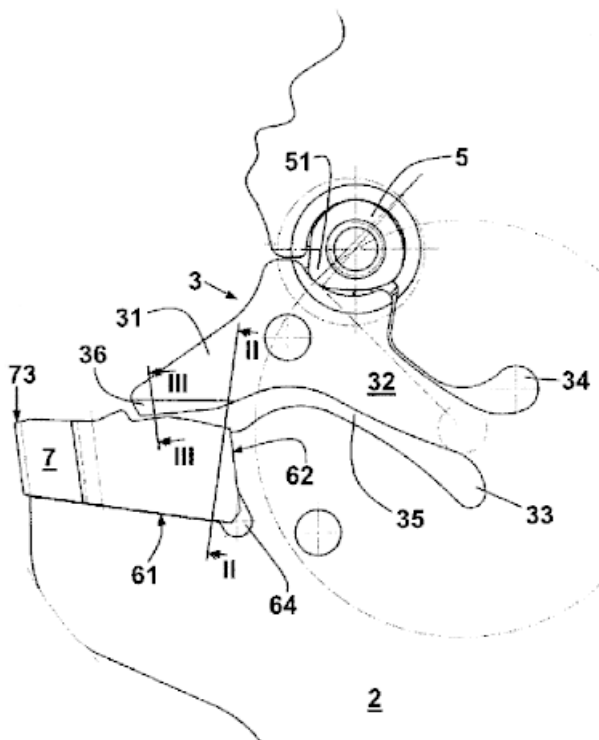
**B23D 63/00**

**Dressing the tools of sawing machines or sawing devices for use in cutting any kind of material, e.g. in the manufacture of sawing tools**

**References****Informative references**

*Attention is drawn to the following places, which may be of interest for search:*

Sharpening the cutting edges or saw teeth of mortise chain cutters	<a href="#">B24B 3/14</a>
Heat treatment for saw blades	<a href="#">C21D 9/24</a>

## B23D 63/0055

{with tooth engaging feed}

### Definition statement

*This place covers:*

Mechanisms for feeding the saw to the devices which operate upon the saw handle or teeth, which comprise a reciprocating pawl or other means for engaging successive teeth of the saw to feed the saw forward.

Illustrative example of subject matter classified in this place:

Note, in the figure below, pawl 30 that engages teeth successively.

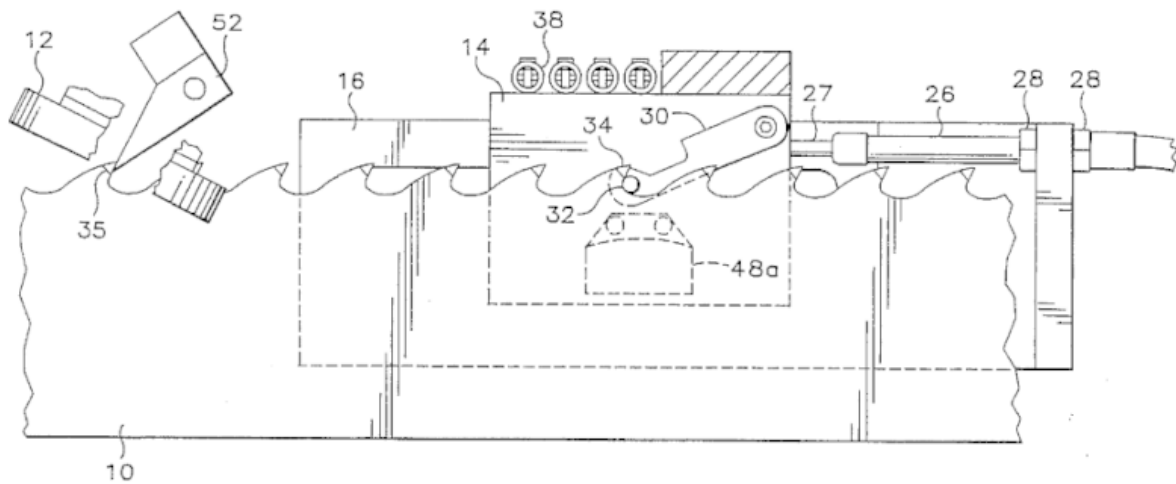

## B23D 63/028

{with screw-operated setting}

### Definition statement

*This place covers:*

Machines in which the tooth-setting devices are forced into engagement with the teeth by means of a screw.

Illustrative example of subject matter classified in this place:

Note, in the figure below, screw 33.

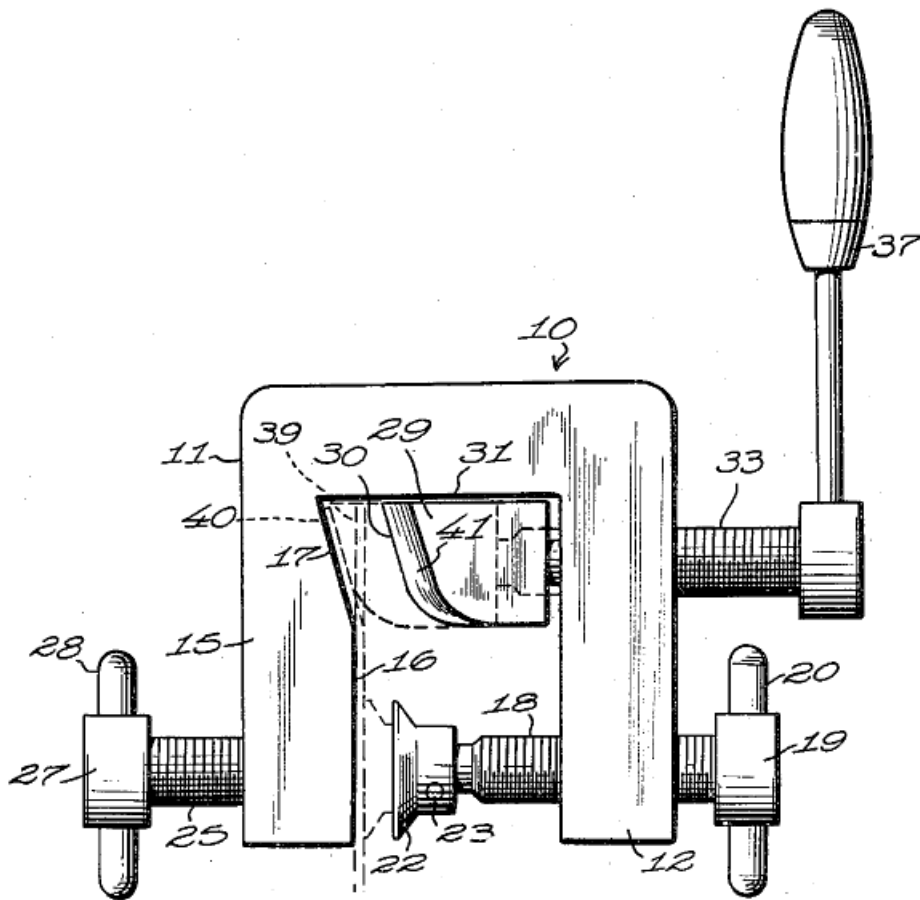

## B23D 63/042

{Setting saw teeth by pivotably-operated setting devices}

### Definition statement

*This place covers:*

Machines in which the tooth-setting devices are forced into engagement with the teeth by a pivoting motion.

Illustrative example of subject matter classified in this place:

Note, in the figure below, elements 54 and 55, which pivot along arrows 62,63.

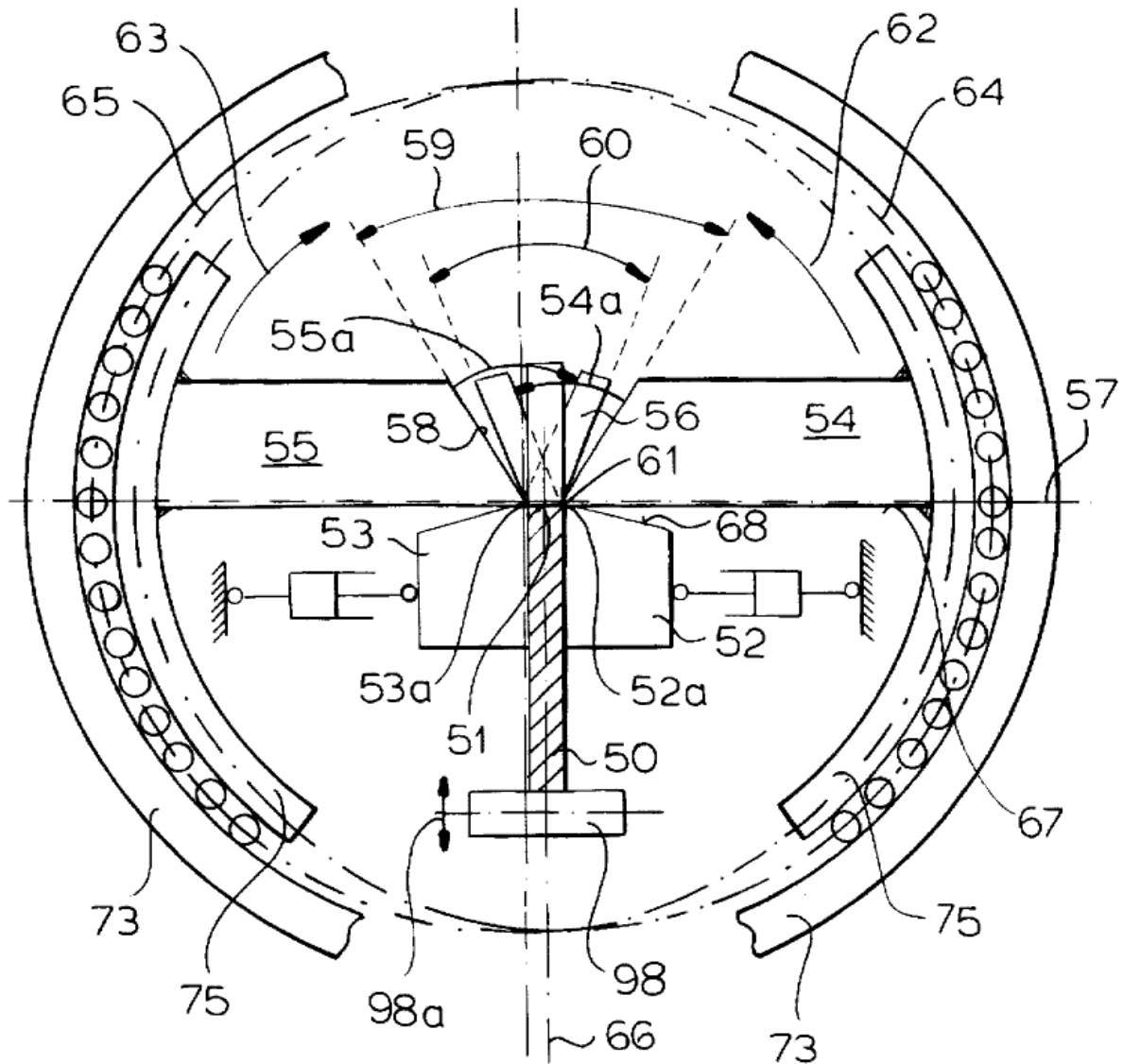

## B23D 63/044

{Setting saw teeth by slidably-operated setting devices}

### Definition statement

*This place covers:*

Machines in which the tooth-setting devices are linearly sliding into engagement with the teeth.

Illustrative example of subject matter classified in this place:

Note, in the figure below, element 30 which slides vertically.

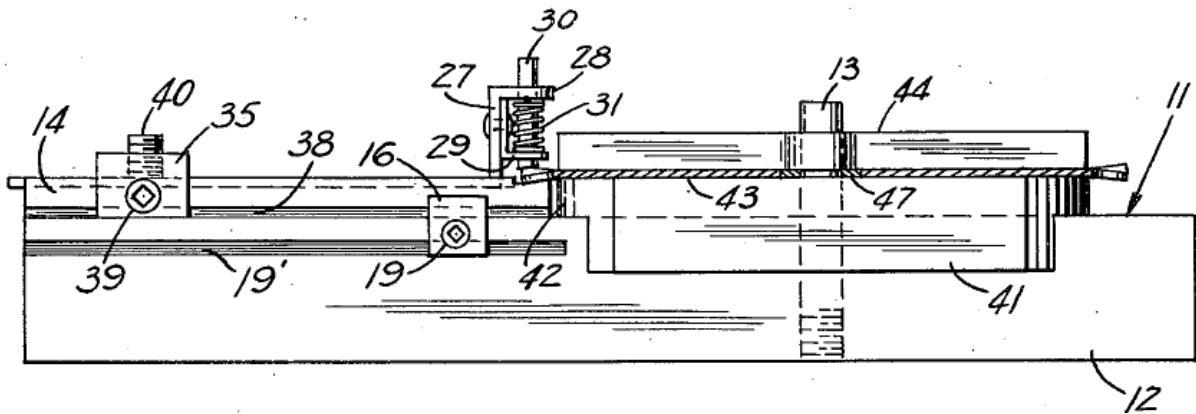

## B23D 63/046

{Tooth embracing; Anvil-free setting}

### Definition statement

*This place covers:*

Machines and implements having means for embracing the tooth, the lateral (or oscillating) movement of the device serving to bend the tooth to the proper set without the cooperation of an anvil. Machines and implements covered by this classification place are mainly manual devices, but some powered devices are covered also by this group.

Illustrative example of subject matter classified in this place:

Note, in the figure below, the tooth is embraced by the slot 3 and then bent, without the use of any anvil

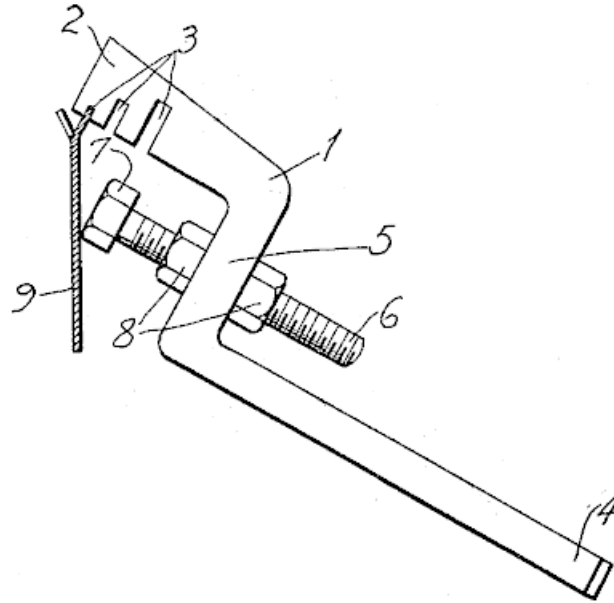

## **B23D 63/072**

**{Jointing}**

### **Definition statement**

*This place covers:*

Furbishing apparatus for making the teeth a desired common height.

The jointing tool could also be things other than an abrading tool, such as a deforming tool.

Illustrative example of subject matter classified in this place:



Note, in the figure below, an abrading tool (8) can be used to set the tooth height.

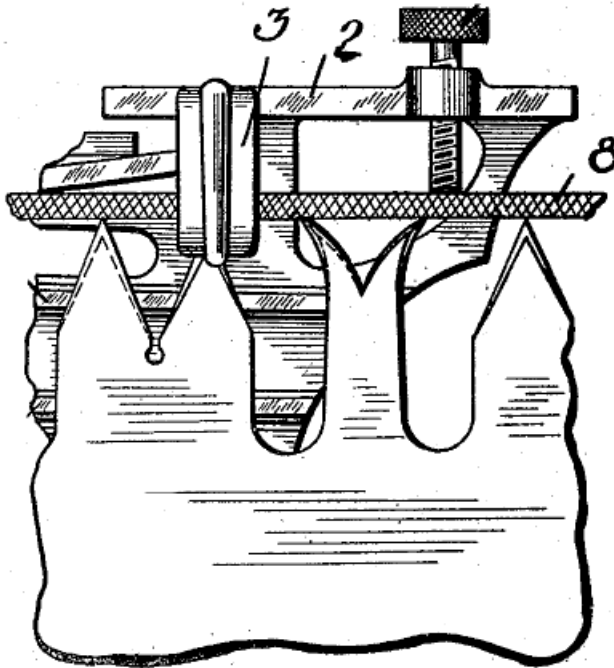

## B23D 65/00

Making tools for sawing machines or sawing devices for use in cutting any kind of material

### References

#### Informative references

Attention is drawn to the following places, which may be of interest for search:

Heat treatment for saw blades	<a href="#">C21D 9/24</a>
-------------------------------	---------------------------

## B23D 65/045

{Making saw blades by using tooth inserters}

### Definition statement

*This place covers:*

Tooth inserting tools especially adapted for inserting saw teeth into a saw blade or extracting saw teeth from the saw blade.

Illustrative examples of subject matter classified in this place:

Note, as shown in Fig. 1 below, the tooth inserting tool could be a simple hand tool.

1.

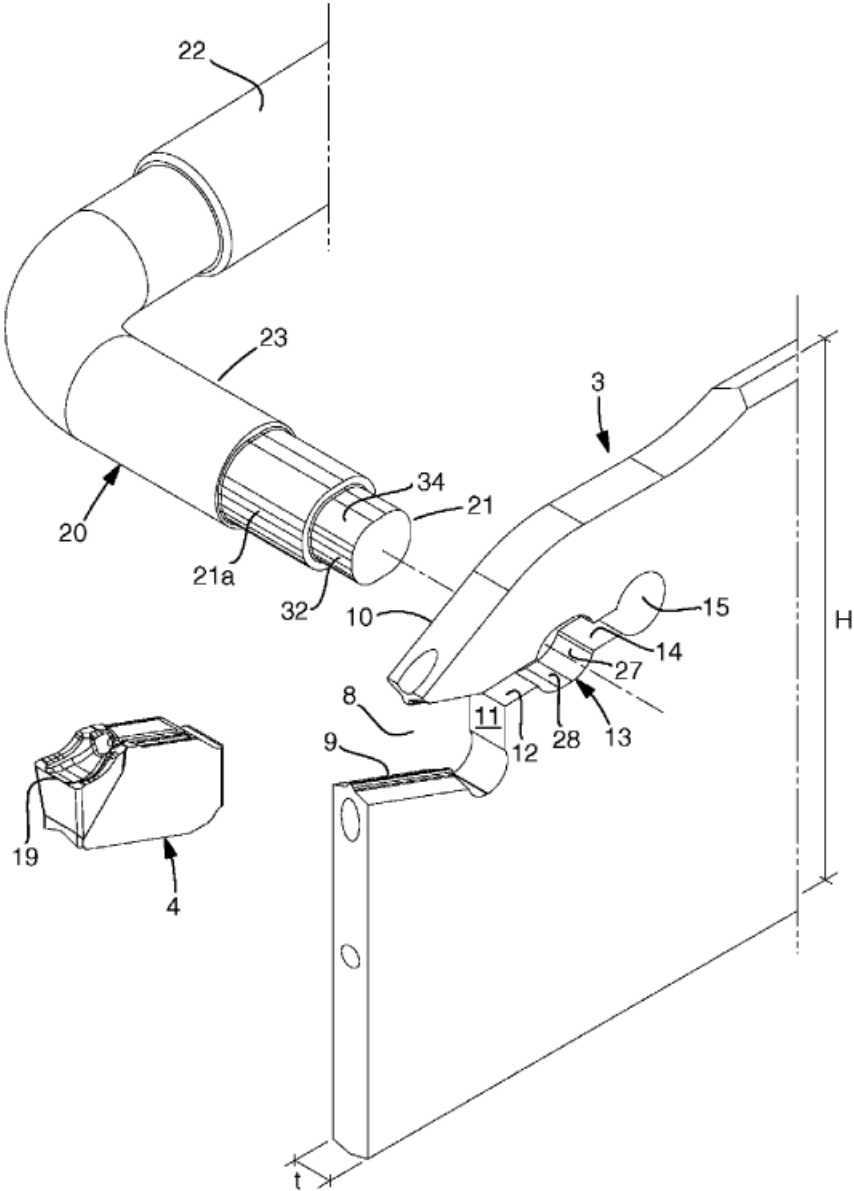

Note, as shown in Fig. 2 below, the tooth inserting tool could be a more complicated machine.

2.

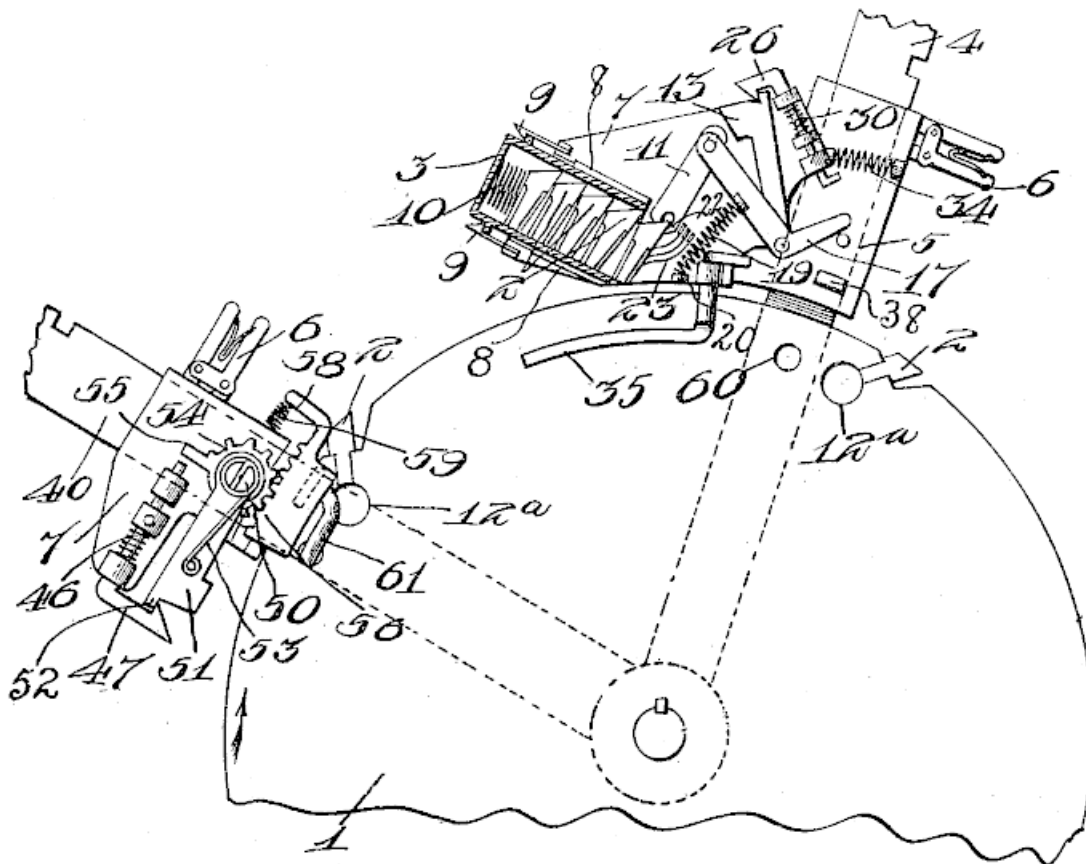

## B23D 67/00

Filing or rasping machines or devices (securing arrangements for files or rasps  
[B23D 71/00](#))

### Definition statement

*This place covers:*

Filing or rasping machines or devices; Filing entails the removal of material in the form of chips by a tool having multiple geometrically defined cutting edges arranged at similar distances from a datum line interior to the tool extending parallel to the path of relative movement between tool and work in order to produce a surface of predetermined form. Rasping is a type of filing using a coarse file with multiple geometrically defined raised teeth usually formed in a sheet of metal by deformation of the sheet.

Illustrative example(s) of the subject matter classified in this group:

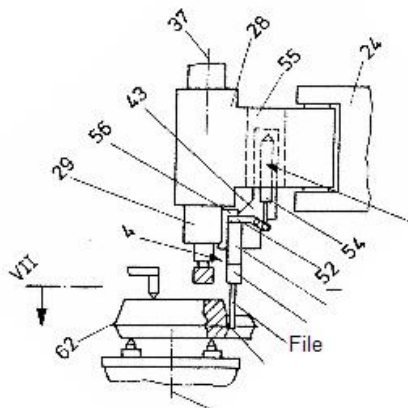

Filing machine with reciprocating tool [B23D 67/02](#) or [B23D 67/04](#)

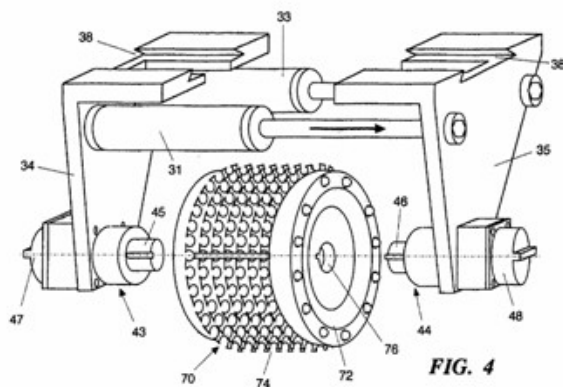

Rasping machine with rotary tool for rubber like materials (tyres)

[B23D 67/06](#), [B23D 67/10](#) (and additionally [B23D 71/025](#))

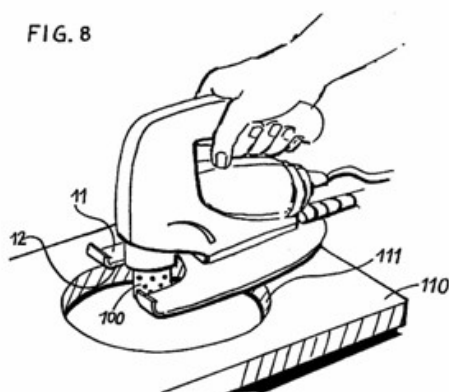

Hand held rasping machine [B23D 67/12](#)

### **Relationships with other classification places**

Filing or rasping is similar in nature to grinding, which is classified in [B24B](#) and [B24D](#). The principal difference between grinding and rasping or filing is that in grinding material is removed by a tool having cutting edges of undefined angles. Grinding tools usually consist of abrasive particles embedded in a fixing medium. In filing or rasping the approach and rake angles of the cutting edges

Relationships with other classification places

are usually known and determined by the configuration of the tool. Files generally have rows or fine teeth arranged in a pattern and are used for relatively precise work. Rasps are in general designed for coarser (rougher) work and may (but may not) have randomly arranged cutting edges.

## References

### Limiting references

*This place does not cover:*

Sharpening saw teeth by filing	<a href="#">B23D 63/10</a>
Securing arrangements for files or rasps	<a href="#">B23D 71/00</a>
Sharpening files by etching	<a href="#">C23F 1/06</a>
Methods or machines for the manufacture of files or rasps that use non-mechanical methods	subclass according to non-mechanical method

### Application-oriented references

*Examples of places where the subject matter of this place is covered when specially adapted, used for a particular purpose, or incorporated in a larger system:*

Sharpening saw teeth by filing	<a href="#">B23D 63/10</a>
--------------------------------	----------------------------

### Informative references

*Attention is drawn to the following places, which may be of interest for search:*

Farriers' tools including files for horses' hooves	<a href="#">A01L 11/00</a>
Personal grooming including nail files	<a href="#">A45D</a>
Bone rasps and other tools for surgery	<a href="#">A61B</a>
Veterinary instruments for animals' teeth including files	<a href="#">A61D 5/00</a>
Constructional features of machine tools in general	<a href="#">B23Q</a>
Grinding machines and methods	<a href="#">B24B</a>
Abrasive Blasting including sandblasting	<a href="#">B24C</a>
Grinding tools	<a href="#">B24D</a>
Chisels for metal	<a href="#">B25D 3/00</a>
Handles for hand implements	<a href="#">B25G</a>
Rasps for wood	<a href="#">B27G 17/06</a>
Recovery of plastics from other materials including rasping of tyres	<a href="#">B29B 17/02</a>
Sharpening files by etching	<a href="#">C23F 1/06</a>

### Special rules of classification

Classification in group [B23D 67/00](#) is simply according to a literal interpretation of the group and subgroup headings, taking into account the notes concerning precedence and the references contained within the subgroups.

## B23D 69/00

Filing or rasping machines or devices. characterised only by constructional features of particular parts, e.g. guiding arrangements, drives (constructional features of these parts per se [B23Q](#)); Accessories for filing or rasping (attached to the tool [B23D 71/10](#))

### Definition statement

*This place covers:*

Filing or rasping machines or devices. characterised only by constructional features of particular parts, e.g. guiding arrangements, drives

Accessories for filing or rasping.

## B23D 71/00

Filing or rasping tools; Securing arrangements therefor (tool holders for machine tools [B23Q 3/00](#); handles for hand implements [B25G](#))

### Definition statement

*This place covers:*

Filing or rasping tools and securing arrangements for filing and rasping tools. Filing tools generally have multiple geometrically defined cutting edges arranged at similar distances from a datum line interior to the tool extending parallel to the path of relative movement between tool and work in order to produce a surface of predetermined form by chip removal. A rasp is a type of course file with multiple geometrically defined raised teeth usually formed in a sheet of metal by deformation of the sheet.

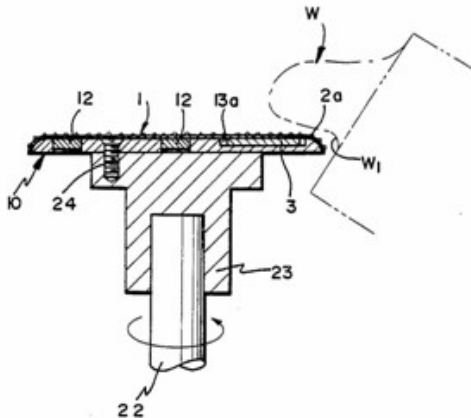

Rotary filling tool [B23D 71/005](#)

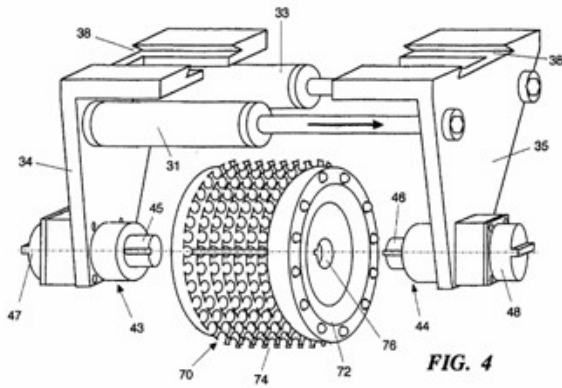

Rasp machine with rotary tool for rubber like materials (tyres)

[B23D 71/025](#) (and additionally [B23D 67/06](#), [B23D 67/10](#))

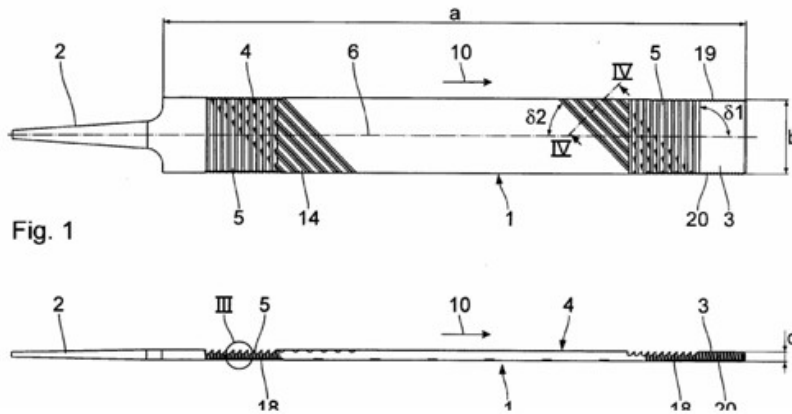

Hand file [B23D 71/04](#)

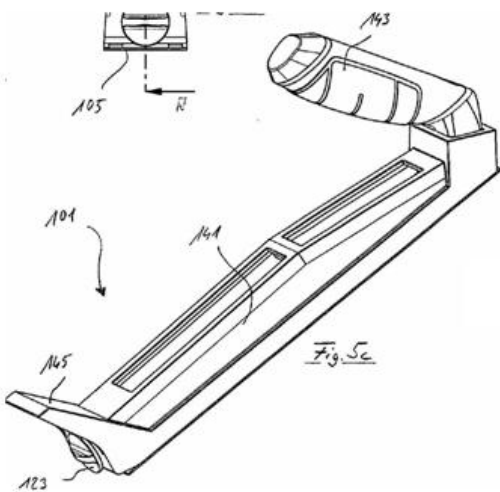

Hand rasp with single interchangeable blade [B23D 71/06](#)

## B23D 73/00

### Making files or rasps

#### Definition statement

*This place covers:*

Making files or rasps.

#### References

##### Informative references

*Attention is drawn to the following places, which may be of interest for search:*

Filing or rasping machines or devices	<a href="#">B23D 67/00</a>
---------------------------------------	----------------------------

## B23D 75/00

### Reaming machines or reaming devices (tool holders for machine tools [B23Q 3/00](#); handles for hand implements [B25G](#))

#### Definition statement

*This place covers:*

Machines specifically designed for reaming. Reaming involves enlarging the size of a previously formed hole by a small amount but with a high degree of accuracy to leave smooth sides through the removal of chips using a tool rotating relatively to a workpiece about the axis of the hole to be produced and moving along this axis relatively to the workpiece. It is to be noted that most reaming is carried out on machines also designed for drilling and tapping, which machines are not classed in [B23D 75/00](#), as they are not specifically designed for reaming.

#### Relationships with other classification places

A reaming tool usually includes a short inclined major cutting edge and a longer calibrating auxiliary edge. A reaming tool is also used such that its axis is generally coincident with the axis of the bore being reamed and the feed movement is generally along this axis. Some fine boring heads ([B23B 29/03](#), [B23B 29/034](#)) also exhibit these properties. Conversely milling tools ([B23C 5/00](#)) generally have longer major cutting edges, shorter auxiliary cutting edges and the feed motion between tool and workpiece is transverse to the axis of rotation of the tool, except in plunge milling.

Many of the adjustment mechanisms for cutting inserts within a milling tool ([B23C 5/24](#)) would also be applicable to reaming tools.

#### References

##### Limiting references

*This place does not cover:*

Boring heads	<a href="#">B23B 29/03</a>
Chucks suitable for reaming and other tools	<a href="#">B23B 31/00</a>
Milling tools	<a href="#">B23C 5/00</a>
Honing devices or tools	<a href="#">B24B 33/00</a>
Handles for hand implements	<a href="#">B25G</a>



**Informative references**

Attention is drawn to the following places, which may be of interest for search:

Adjustment of cutting insert in turning tool holder	<a href="#">B23B 27/16</a>
Boring heads with tools adjustable radially before commencing machining	<a href="#">B23B 29/03403</a>
Chucks for holding tools	<a href="#">B23B 31/02</a>
Drilling tools	<a href="#">B23B 51/00</a>
Drilling tools with provision for cooling	<a href="#">B23B 51/06</a>
Milling cutters with shafts	<a href="#">B23C 5/10</a>
Milling cutters having adjustable bits or teeth	<a href="#">B23C 5/24</a>
Milling cutters with provision for cooling	<a href="#">B23C 5/28</a>
Constructional details of machine tools in general not particularly related to the operation being performed	<a href="#">B23Q</a>
Provision of cooling within machine tools	<a href="#">B23Q 11/10</a>

**B23D 77/00**

**Reaming tools**

**Definition statement**

*This place covers:*

Reaming tools. Reaming involves enlarging the size of a previously formed hole by a small amount but with a high degree of accuracy to leave smooth sides through the removal of chips using a tool rotating relatively to a workpiece about the axis of the hole to be produced and moving along this axis relatively to the workpiece. A reaming tool usually (but not necessarily) includes a short inclined primary cutting edge and a longer calibrating auxiliary edge.

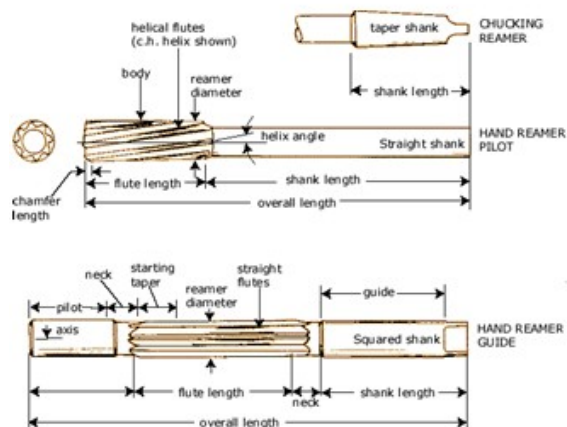

Reamer. Nomenclature of reamer shown [B23D 77/00](#)

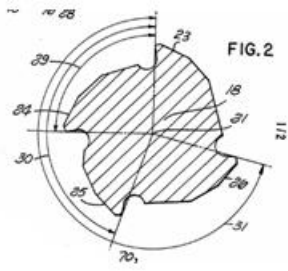

Reamer with unequal distribution of flutes to prevent chatter (vibration) [B23D 77/003](#)

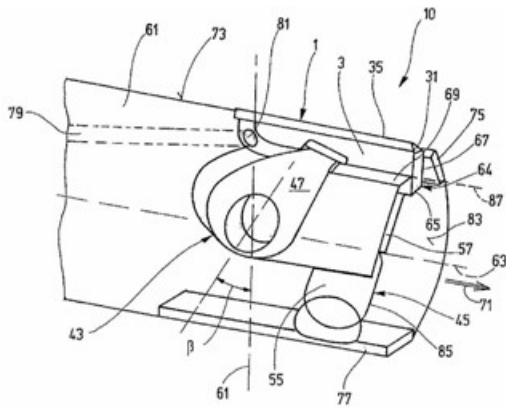

securing arrangement for insert in reamer [B23D 77/025](#)

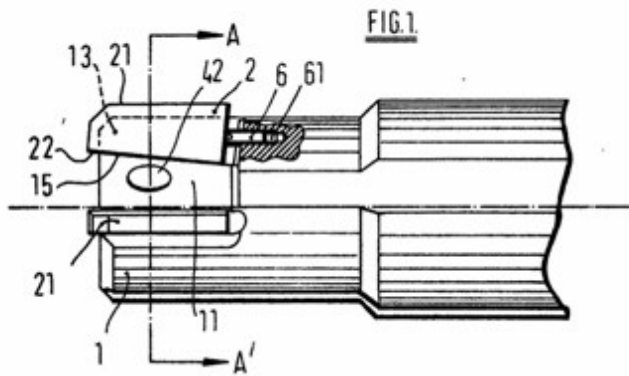

Adjustment of diameter by oblique planes (15,22) [B23D 77/042](#)

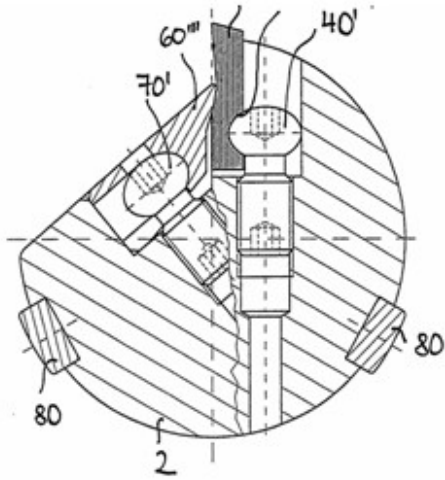

Adjustment of diameter by screws [B23D 77/044](#)

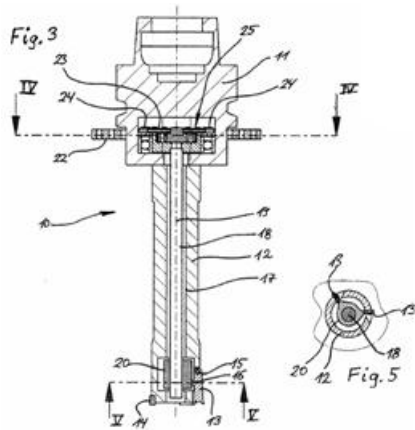

adjustment of diameter by radial cams [B23D 77/046](#)

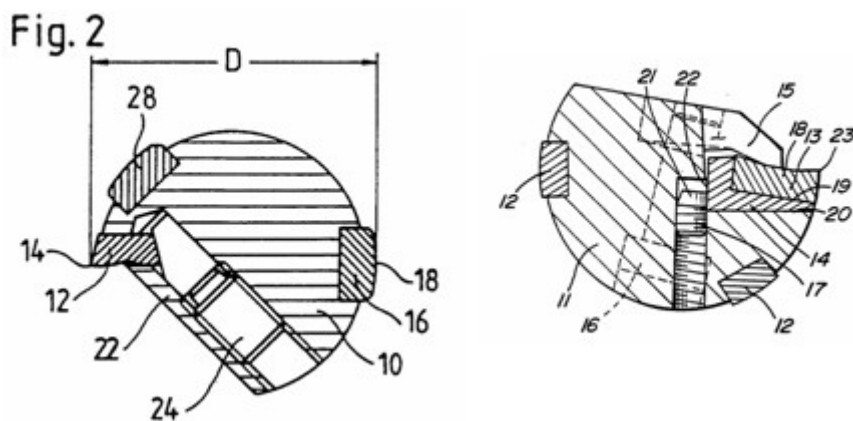

Definition statement

Adjustment of diameter by conical screws [B23D 77/048](#)

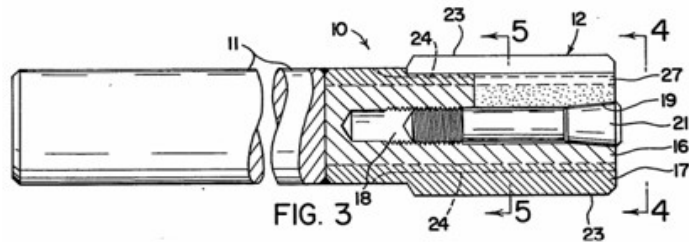

Expandable reamer with slots [B23D 77/08](#)

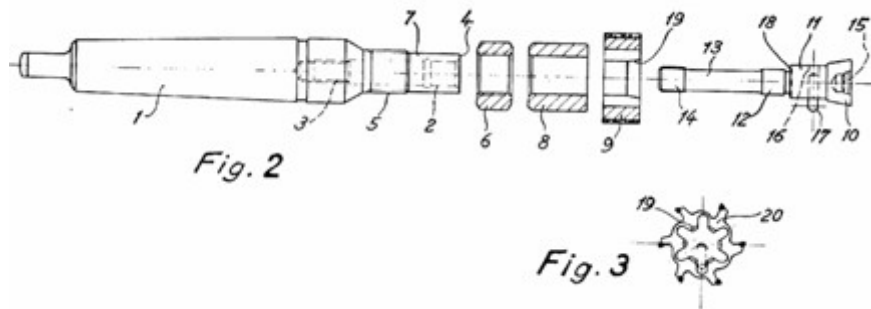

Expandable reamer without slots [B23D 77/10](#)

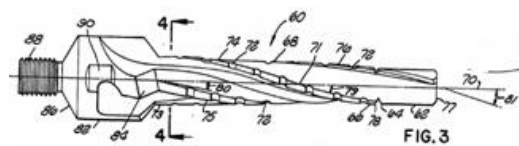

Tapered reamer [B23D 77/12](#)

## Relationships with other classification places

A reaming tool usually includes a short inclined major cutting edge and a longer calibrating auxiliary edge. A reaming tool is also used such that its axis is generally coincident with the axis of the bore being reamed and the feed movement is generally along this axis. Some fine boring heads ([B23B 29/03](#), [B23B 29/034](#)) also exhibit these properties though usually boring heads do not have a calibrating auxiliary cutting edge. Conversely milling tools ([B23C 5/00](#)) generally have longer major cutting edges, shorter auxiliary cutting edges and the feed motion between tool and workpiece is transverse to the axis of rotation of the tool, except in plunge milling.

Many of the adjustment mechanisms for cutting inserts within a milling tool ([B23C 5/24](#)) would also be applicable to reaming tools.

## References

### Informative references

Attention is drawn to the following places, which may be of interest for search:

Adjustment of cutting insert in turning tool holder	<a href="#">B23B 27/16</a>
Boring heads	<a href="#">B23B 29/03</a>
Boring heads with tools adjustable radially before commencing machining	<a href="#">B23B 29/03403</a>
Chucks suitable for reaming and other tools	<a href="#">B23B 31/00</a>

Chucks for holding tools	<a href="#">B23B 31/02</a>
Drilling tools	<a href="#">B23B 51/00</a>
Drilling tools with provision for cooling	<a href="#">B23B 51/06</a>
Milling tools	<a href="#">B23C 5/00</a>
Milling cutters with shafts	<a href="#">B23C 5/10</a>
Milling cutters having adjustable bits or teeth	<a href="#">B23C 5/24</a>
Milling cutters with provision for cooling	<a href="#">B23C 5/28</a>
Constructional details of machine tools in general not particularly related to the operation being performed	<a href="#">B23Q</a>
Provision of cooling within machine tools	<a href="#">B23Q 11/10</a>
Honing devices or tools	<a href="#">B24B 33/00</a>
Handles for hand implements	<a href="#">B25G</a>

### Special rules of classification

For [B23D 77/00](#) and subgroups, a 2000-series Indexing Code system is present ([B23D 2277/00](#)). Indexing Codes this series should be allocated at every opportunity. When classifying reaming tools particular attention should be paid to the Indexing Codes. Indexing Codes should also be added routinely to give details of the workpiece or tool configuration.

For example, a document showing a particular reaming tool having a particular configuration of adjustment mechanism for the cutting blade and showing explicit provision for coolant may be given a classification for the details of the adjustment mechanism as this forms the subject of the invention. Such a document should also be allocated Indexing Codes relating to the provision of coolant and/or further details of the reaming tool itself to allow easy retrieval.

The 2000-series Indexing Codes relating to the material of tool or workpiece should also be routinely allocated where available. However, in this instance, where a material is generally used for a particular part (e.g. tungsten carbide for an cutting insert or blade, steel for a reaming cutter body), the Indexing Code for the material concerned should only be allocated if further details of the material itself are present in the document.

## B23D 79/00

**Methods, machines, or devices not covered elsewhere, for working metal by removal of material (by combined operations [B23D 81/00](#); cutting by electron-beam [B23K 15/00](#), by laser beam [B23K 26/00](#); by electro-erosion [B23H](#); tool holders for machine tools [B23Q 3/00](#); handles for hand implements [B25G](#))**

### Definition statement

*This place covers:*

Methods, machines, or devices not covered elsewhere, for working metal by removal of material.

Illustrative example of subject matter classified in this group:

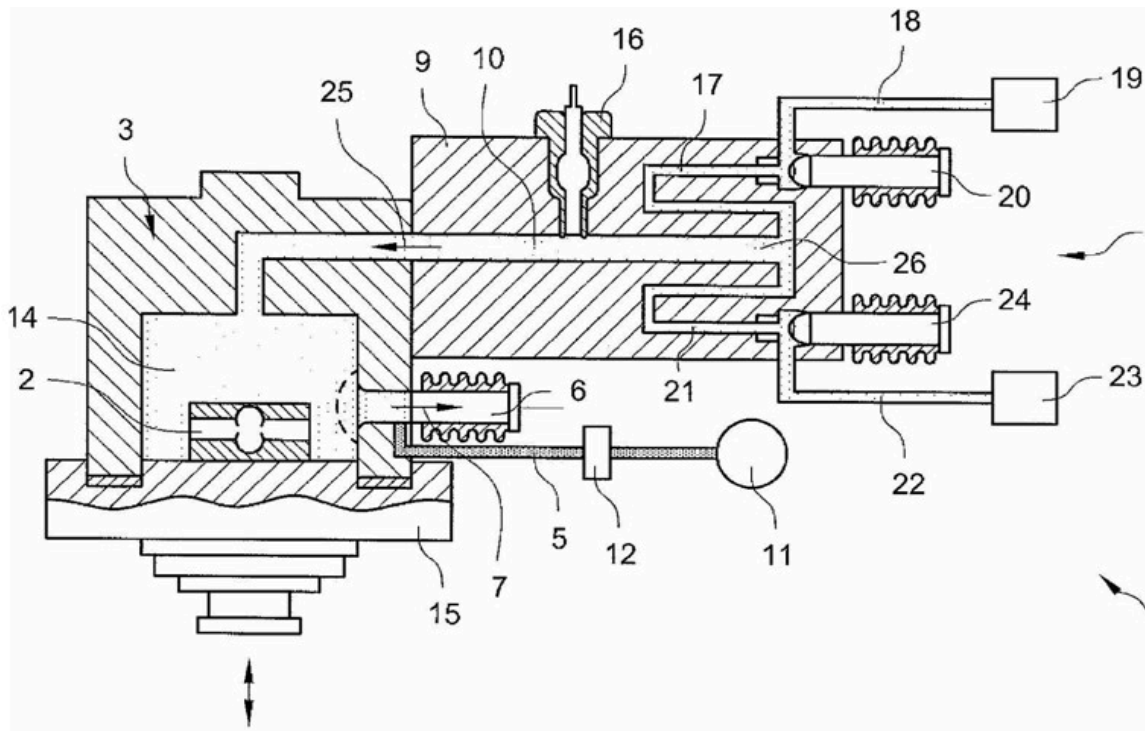

Thermal deburring of workpiece (2) in a chamber (14) by igniting a mixture of gas (from supply 19) and oxygen (from supply 23) using a spark providing device (16). This type of device is commonly used to deburr inaccessible intersections of drilling within workpieces. [B23D 79/005](#)

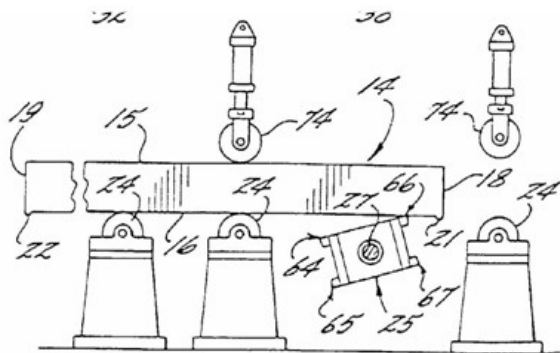

Scraping (deburring) device to remove dross from end of cut metal workpiece [B23D 79/02](#)

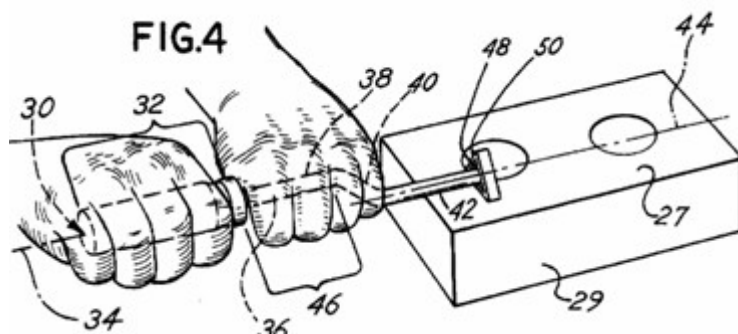

Hand scraping device for deburring and/or cleaning [B23D 79/02](#)

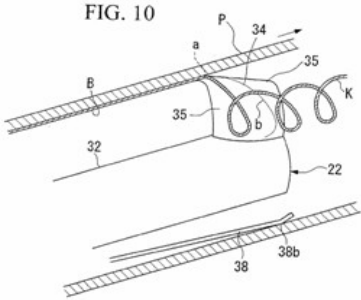

Removal of internal bead from pipe by scraping [B23D 79/023](#)

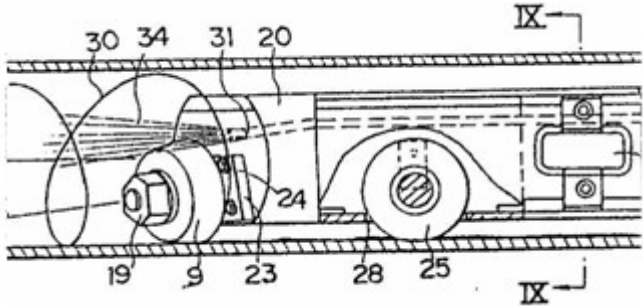

Removal of internal pipe bead with additional equipment (hot gas31) [B23D 79/025](#)

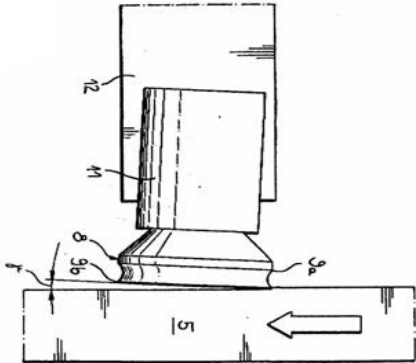



Scraping device with rotating cutting tool [B23D 79/04](#)

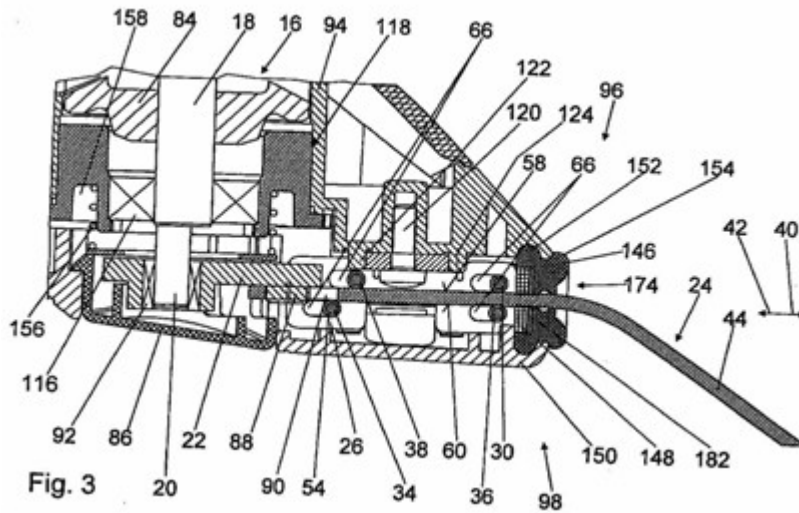

Scraping devices with reciprocating tool [B23D 79/06](#)

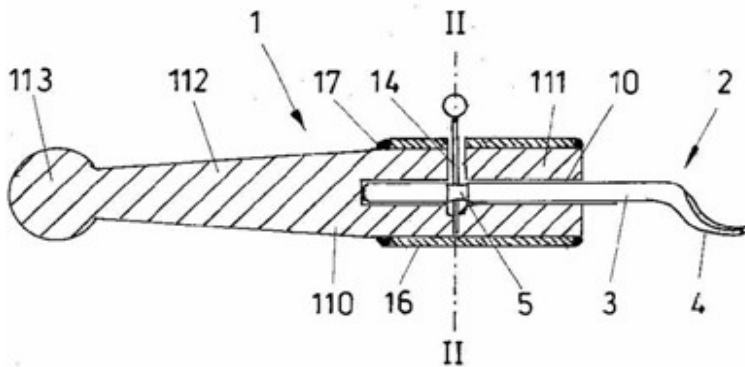

Hand scraping device for deburring [B23D 79/08](#)

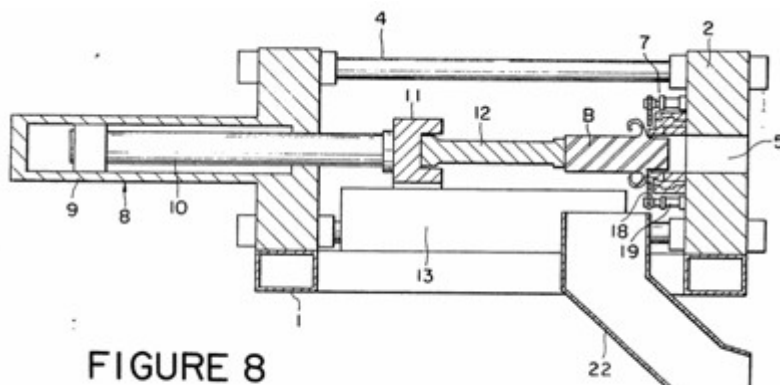

Bar peeling device not working by turning [B23D 79/12](#)

### Relationships with other classification places

This group is only used when the removal of metal cannot be classified in a more suitable field elsewhere in the CPC schemes.



Relationships with other classification places

Attention is also drawn to the notes for [B23](#), which define the term "metal" as including other materials unless the context determines otherwise. In this group the inclusion of the word "metal" indicates that this group should not be used for the removal of materials other than metal.

## References

### Limiting references

*This place does not cover:*

Removal of material by combined operations all classed within <a href="#">B23D</a>	<a href="#">B23D 81/00</a>
Cutting (including deburring) by electro-erosion (EDM) or electro-chemical machining (ECM)	<a href="#">B23H</a>
Cutting (including deburring) by electron-beam	<a href="#">B23K 15/00</a>
Cutting (including deburring) by laser beam	<a href="#">B23K 26/00</a>
Work holding devices for machine tools	<a href="#">B23Q 3/00</a>
Handles suitable for hand scraping implements	<a href="#">B25G</a>

### Informative references

*Attention is drawn to the following places, which may be of interest for search:*

Removal of material by planing (shaping), slotting, shearing, broaching, sawing, filing, rasping or reaming: Like operations for working metal by removing material, not otherwise provided for	<a href="#">B23D</a>
Cleaning using scrapers	<a href="#">B08B</a>
Removal of material by turning, boring, drilling; in particular:	<a href="#">B23B</a>
Machines or devices for chamfering the ends of bars or tubes	<a href="#">B23B 5/16</a>
Chucks suitable to hold scraping and other tools	<a href="#">B23B 31/00</a>
Deburring by use of a drilling tool	<a href="#">B23B 51/10</a>
Removal of material by milling; in particular:	<a href="#">B23C</a>
Deburring by milling	<a href="#">B23C 3/12</a>
Cutting (including deburring) by electro-erosion (EDM) or electro-chemical machining (ECM)	<a href="#">B23H</a>
Cutting using flames (e.g. oxy-acetylene)	<a href="#">B23K 7/00</a>
Cutting (including deburring) using an arc	<a href="#">B23K 9/013</a>
Cutting (including deburring) using Plasma	<a href="#">B23K 10/00</a>
Cutting (including deburring) by electron-beam; Auxiliary devices for flash removal after welding	<a href="#">B23K 37/08</a>
Removal of material by combined operations not all classed within <a href="#">B23D</a>	<a href="#">B23P 13/00</a>
Removal of material by grinding; in particular: Deburring or cleaning by grinding	<a href="#">B24B</a> , <a href="#">B24D</a> , <a href="#">B24B 9/00</a> , <a href="#">B24B 27/033</a>
Cutting using liquid jets containing abrasive; Deburring using liquid jets using liquid without abrasive particles	<a href="#">B24C</a>
Work holding devices for machine tools	<a href="#">B25B</a>
Severing using a liquid jet, not containing abrasive particles	<a href="#">B26F 3/004</a>

### Special rules of classification

Classification [B23D 79/00](#) is according to the literal interpretation of the subgroup headings, taking into account the notes concerning precedence rules and the references contained within the subgroups.

## B23D 81/00

**Methods, machines, or devices for working metal, covered by more than one main group in this subclass (in combination with other metal-working operations [B23P 13/00](#), [B23D 23/00](#))**

### Definition statement

*This place covers:*

Methods, machines, or devices for working metal, covered by more than one main group in [B23D 1/00](#) - [B23D 79/12](#).

### References

#### Limiting references

*This place does not cover:*

Making metal objects by operations essentially involving machining but not covered by a single other subclass	<a href="#">B23P 13/00</a>
Making specific metal objects by operations not covered by a single other subclass	<a href="#">B23P 15/00</a>
Machines or arrangements of machines for performing specified combinations of different metal-working operations not covered by a single other subclass	<a href="#">B23P 23/00</a>

## B23D 2277/2407

**Applied by chemical vapour deposition [CVD] processes**

### References

#### Informative references

*Attention is drawn to the following places, which may be of interest for search:*

Chemical coating by decomposition of gaseous compounds without leaving reaction products of surface material in the coating, i.e. chemical vapour deposition [CVD] processes	<a href="#">C23C 16/00</a>
--	----------------------------

## B23D 2277/2414

**Applied by physical vapour deposition [PVD] processes**

### References

#### Informative references

*Attention is drawn to the following places, which may be of interest for search:*

Coating by vacuum evaporation, by sputtering or by ion implementation of the coating forming material	<a href="#">C23C 14/00</a>
---	----------------------------