

## B07B

**SEPARATING SOLIDS FROM SOLIDS BY SIEVING, SCREENING, SIFTING OR BY USING GAS CURRENTS; SEPARATING BY OTHER DRY METHODS APPLICABLE TO BULK MATERIAL, e.g. LOOSE ARTICLES FIT TO BE HANDLED LIKE BULK MATERIAL (wet separating processes, sorting by processes using fluent material in the same way as liquid [B03](#); combinations of dry separating apparatus with wet separating apparatus [B03B](#); using liquids [B03B](#), [B03D](#); sorting by magnetic or electrostatic separation of solid materials from solid materials or fluids, separation by high voltage electric fields [B03C](#); centrifuges or vortex apparatus for carrying out physical processes [B04](#); hand sorting, postal sorting, sorting by switching or other devices actuated in response to detection or measurement of some feature of articles or samples of material [B07C](#))**

### Definition statement

*This place covers:*

Apparatus or methods for the separation of solids from solids that include:

- Any sorting or grading of bulk material or loose articles fit to be handled like bulk material which results automatically from the construction of the apparatus and properties of the material or articles, e.g. by a trap opening under an object of a certain minimum weight, by an aperture of graduated size.
- Sorting of articles in so far as the same conditions apply, e.g. sorting of timber by passing it over successively longer openings; the articles may or may not be orientated for the purpose of sorting.
- Sieving, screening, sifting or sorting solid materials using networks, gratings, grids or the like.
- Separating solids from solids that are initially a mixture using apparatus or methods that subject the mixture to a gas current, dispenses the mixture within a gas, carries the mixture on a gas current while it is being separated, or uses a gas current on it to cause separation, including combinations of disparate types of apparatus utilizing gas currents in the separation of solids from solids.
- Other types of apparatus for directly controlled dry method grading or sorting of solid materials in a bulk form or of loose articles that are being handled like solid type bulk material, e.g. grading according to size or weight or using momentum effects.
- Constructional features of screens per se, or screens and their driving mechanisms, which are used in dry or wet separating methods.
- Combinations of disparate types of apparatus or methods for separating solids from solids that applicable to bulk material or to loose articles fit to be handled like bulk material.
- Accessories that are specially adapted for, or arranged in conjunction with, the above types of separating, sorting or grading of bulk material or articles.

## B07B 1/005

{Transportable screening plants}

### Definition statement

*This place covers:*

Illustrative example of subject matter classified in this group:

WO-A1-96/25245

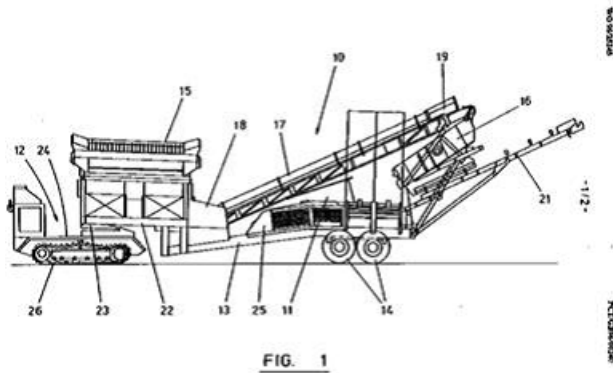

## **B07B 1/02**

### **Hand screens**

#### **Definition statement**

*This place covers:*

Illustrative example of subject matter classified in this group:

LU-A2-91105

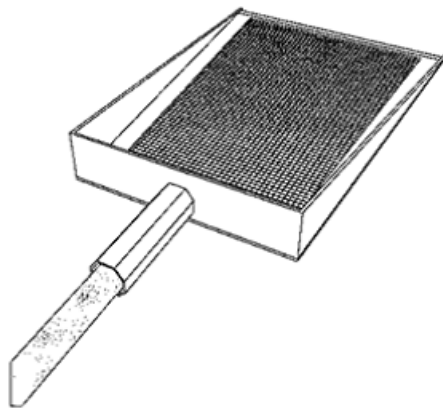

## **B07B 1/04**

### **Stationary flat screens**

#### **Definition statement**

*This place covers:*

Illustrative example of subject matter classified in this group:

US-A1-2003/0080031

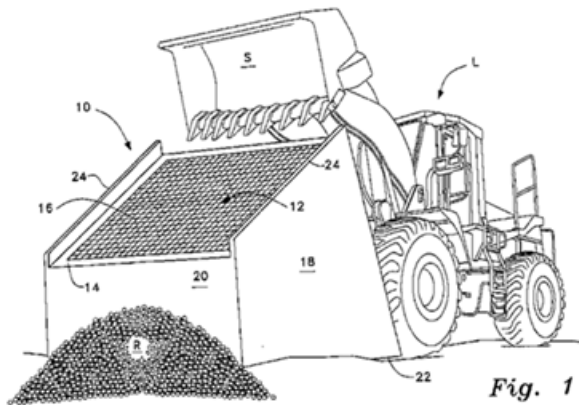

Patent Application Publication May 1, 2003 Sheet 1 of 4 US 2003/0080031 A1

## **B07B 1/06**

### **Cone or disc shaped screens**

#### **Definition statement**

*This place covers:*

Illustrative example of subject matter classified in this group:

GB-A-2307428

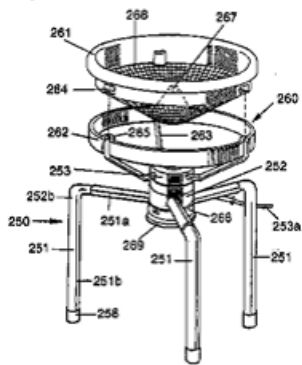

## **B07B 1/08**

### **Screens rotating within their own plane**

#### **Definition statement**

*This place covers:*

Illustrative example of subject matter classified in this group:

EP-A1-0411803

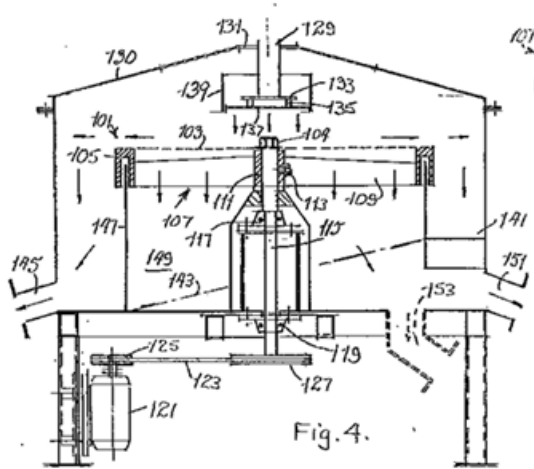

## **B07B 1/10**

### **Screens in the form of endless moving bands**

#### **Definition statement**

*This place covers:*

Illustrative example of subject matter classified in this group:

US-A-5887729

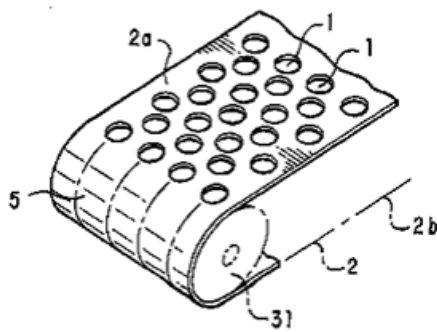

**FIG. 1B**

## **B07B 1/12**

### **Apparatus having only parallel elements**

#### **Definition statement**

*This place covers:*

Illustrative example of subject matter classified in this group:

US-B1-7861867

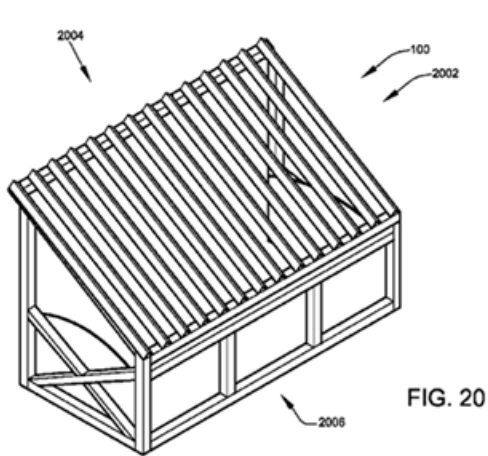

U.S. Patent  
Jan. 4, 2011  
Sheet 18 of 18  
US 7,861,867 B1

## **B07B 1/14**

### **Roller screens**

#### **Definition statement**

*This place covers:*

Illustrative example of subject matter classified in this group:

US-B1-7117996

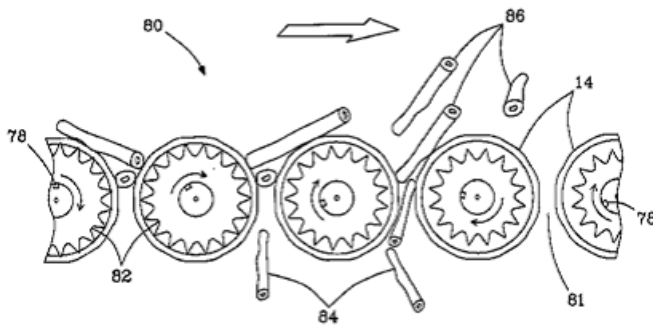

## **B07B 1/15**

### **using corrugated, grooved or ribbed rollers**

#### **Definition statement**

*This place covers:*

Illustrative example of subject matter classified in this group:

EP-A1-2248602

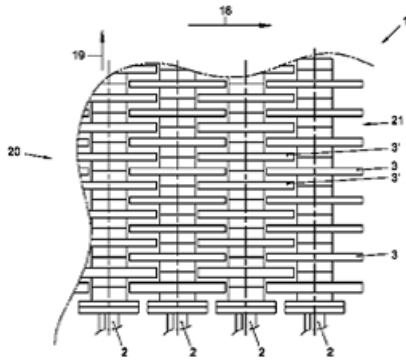

### B07B 1/16

the elements being movable and in other than roller form

#### Definition statement

*This place covers:*

Illustrative example of subject matter classified in this group:

US3971716 A

FIG. 1

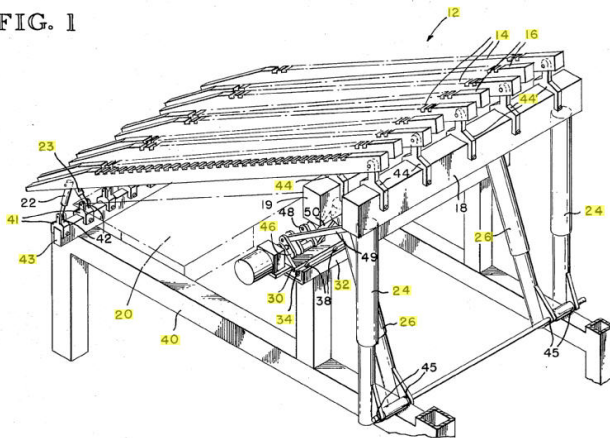

GB326834 A

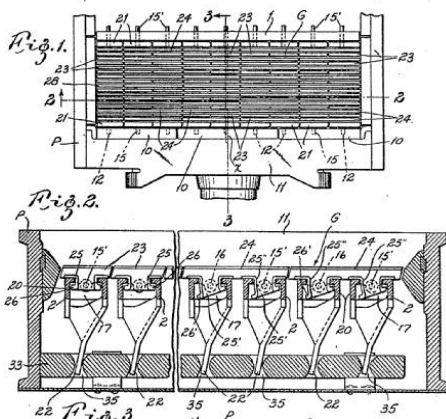

US5392931 A

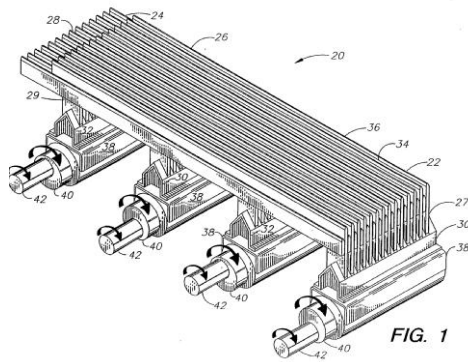

## **B07B 1/20**

### **Stationary drums with moving interior agitators**

#### **Definition statement**

*This place covers:*

Illustrative example of subject matter classified in this group:

FR-A-2686273

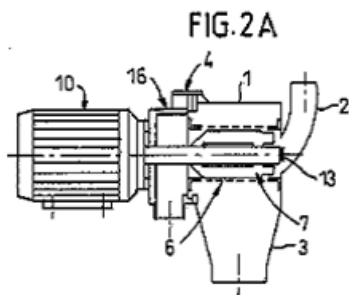

## **B07B 1/22**

### **Revolving drums**

#### **Definition statement**

*This place covers:*

Illustrative example of subject matter classified in this group:

GB-A-536054

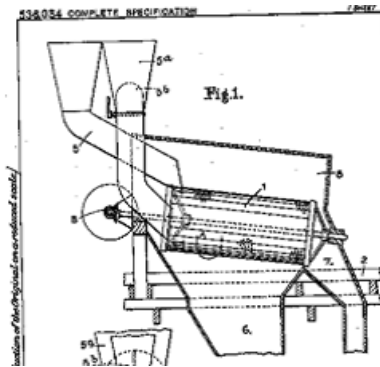

**B07B 1/24**

with fixed or moving interior agitators

**Definition statement**

*This place covers:*

Illustrative example of subject matter classified in this group:

FR-A-2568492

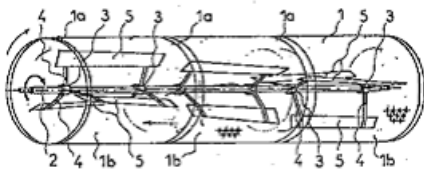

**B07B 1/26**

with additional axial or radial movement of the drum

**Definition statement**

*This place covers:*

Illustrative example of subject matter classified in this group:

WO-A1-84/04473

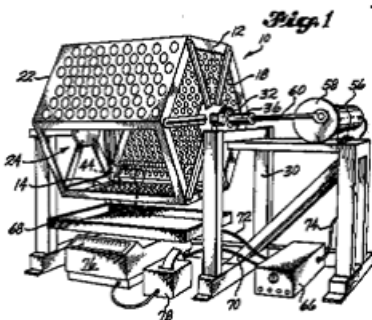



**B07B 1/282**

{their jiggling movement being a closed or open curvilinear path in a plane perpendicular to the plane of the screen and parallel or transverse to the direction of conveyance}

**Definition statement**

*This place covers:*

Illustrative example of subject matter classified in this group:

US-A-2258789

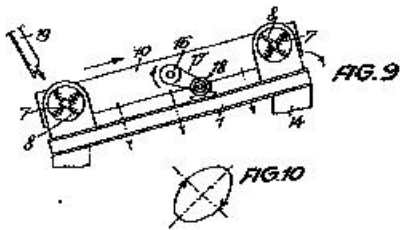
**B07B 1/284**

{with unbalanced weights}

**Definition statement**

*This place covers:*

Illustrative example of subject matter classified in this group:

DE-B-1176979

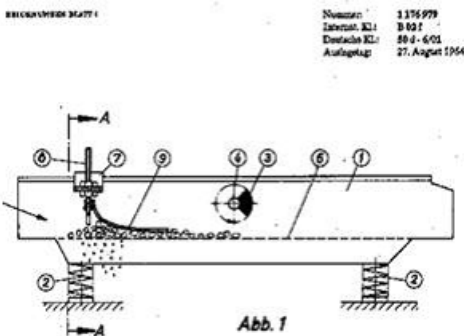
**B07B 1/286**

{with excentric shafts}

**Definition statement**

*This place covers:*

Illustrative example of subject matter classified in this group:

DE-C-948574

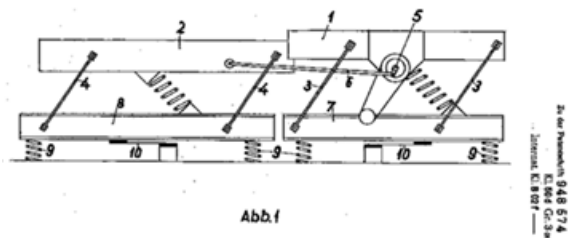

## B07B 1/30

jigging or moving to-and-fro {within their own plane} in or approximately in {or transverse to} the direction of conveyance

### Definition statement

*This place covers:*

Illustrative example of subject matter classified in this group:

DE-A1-4039934

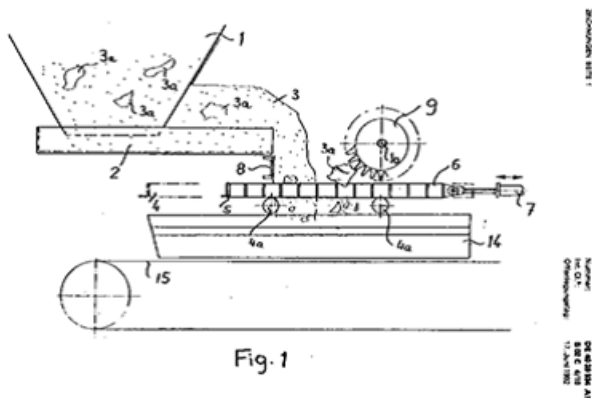

## B07B 1/34

jigging or moving to-and-fro perpendicularly or approximately perpendicularly to the plane of the screen

### Definition statement

*This place covers:*

Illustrative example of subject matter classified in this group:

EP-A2-0212378

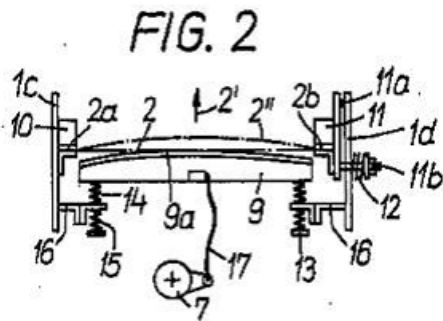

**B07B 1/343**

{with mechanical drive elements other than electromagnets}

**Definition statement**

*This place covers:*

Illustrative example of subject matter classified in this group:

US-E-RE16701

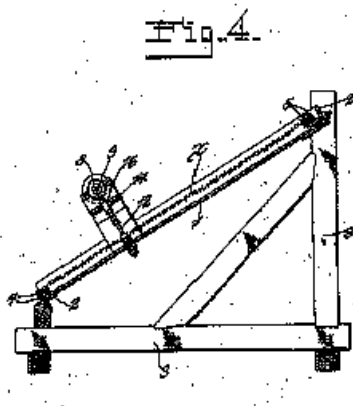

**B07B 1/346**

{with electromagnets}

**Definition statement**

*This place covers:*

Illustrative example of subject matter classified in this group:

DE-A1-2120244

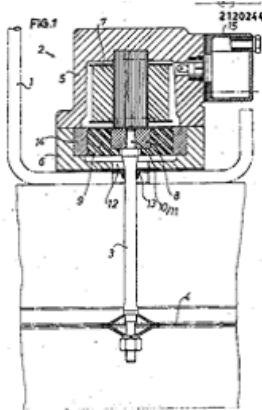

**B07B 1/36**

**jigging or moving to-and-fro in more than one direction**

**Definition statement**

*This place covers:*

Illustrative example of subject matter classified in this group:

WO-A1-03/024626

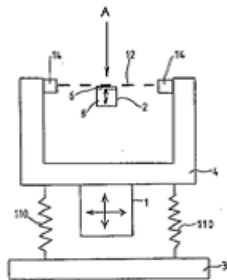

**B07B 1/38**

**oscillating in a circular arc in their own plane; Plansifters**

**Definition statement**

*This place covers:*

Illustrative example of subject matter classified in this group:

DE-C-74002

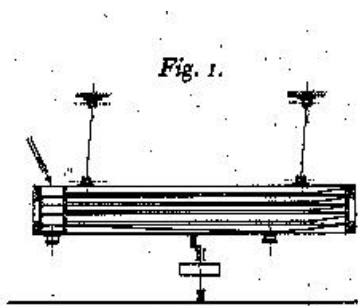

**B07B 1/40****Resonant vibration screens****Definition statement**

*This place covers:*

Illustrative example of subject matter classified in this group:

DE-C1-10054089

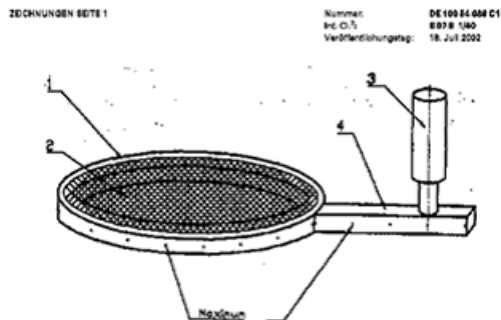
**B07B 1/42****Drive mechanisms, regulating or controlling devices, or balancing devices, specially adapted for screens****Definition statement**

*This place covers:*

Illustrative example of subject matter classified in this group:

GB-A-2123520

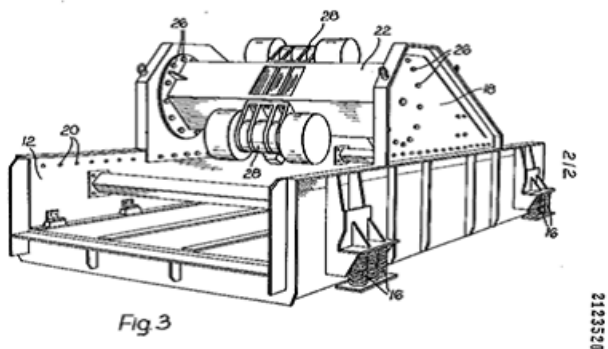
**B07B 1/44****Balancing devices****Definition statement**

*This place covers:*

Illustrative example of subject matter classified in this group:



**B07B 1/4627****{Repairing of screening surfaces}****Definition statement***This place covers:*

Illustrative example of subject matter classified in this group:

WO-A-92/00133

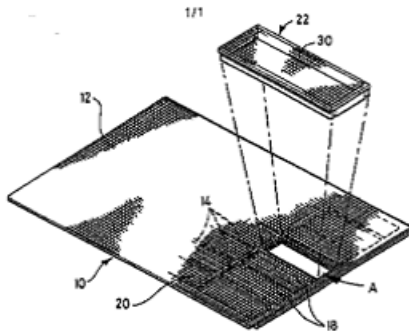
**B07B 1/4636****{Regulation of screen apertures}****Definition statement***This place covers:*

Illustrative example of subject matter classified in this group:

FR-A-1140961

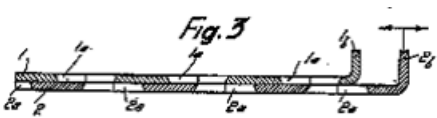
**B07B 1/4645****{Screening surfaces built up of modular elements}****Definition statement***This place covers:*

Illustrative example of subject matter classified in this group:

WO-A1-03/066243

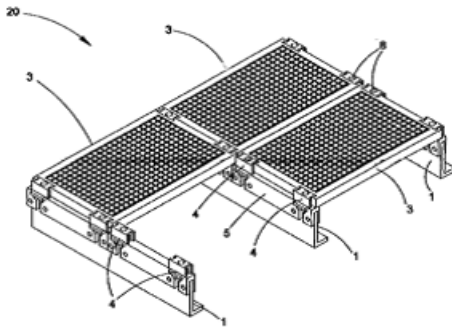

**B07B 1/4654**

{Corrugated Screening surfaces}

**Definition statement**

*This place covers:*

Illustrative example of subject matter classified in this group:

US-B1-6340089

U.S. Patent Jan. 22, 2002 Sheet 2 of 11 US 6,340,089 B1

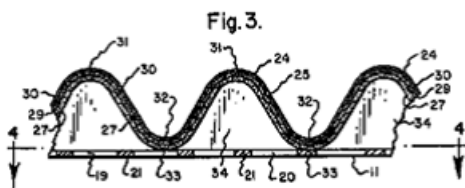

**B07B 1/4663**

{Multi-layer screening surfaces}

**Definition statement**

*This place covers:*

Illustrative example of subject matter classified in this group:

US-A1-2004/0102117

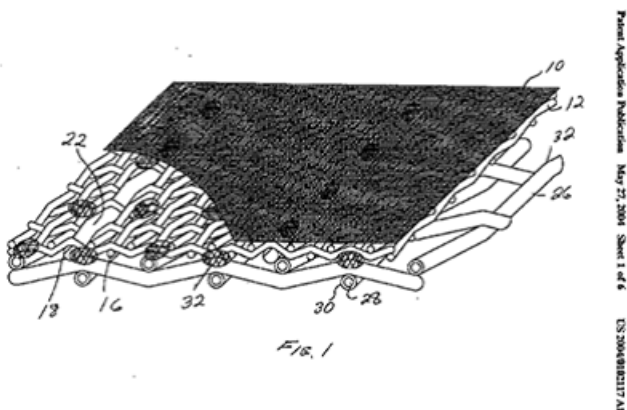

Patent Application Publication May 21, 2004 Sheet 1 of 6 US 2004/0102117 A1



**B07B 1/4672****{Woven meshes}****Definition statement***This place covers:*

Illustrative example of subject matter classified in this group:

DE-U1-29501985

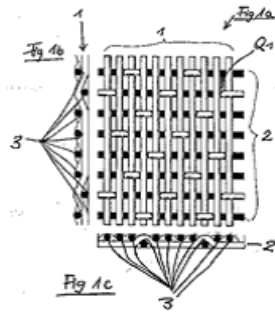
**B07B 1/4681****{Meshes of intersecting, non-woven, elements}****Definition statement***This place covers:*

Illustrative example of subject matter classified in this group:

FR-A1-2880289

2880289

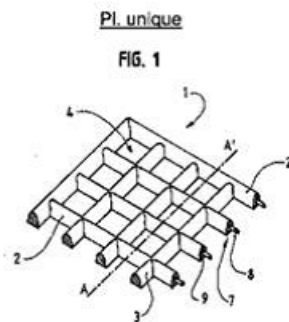
**B07B 1/469****{Perforated sheet-like material}****Definition statement***This place covers:*

Illustrative example of subject matter classified in this group:

DE-U1-20018385

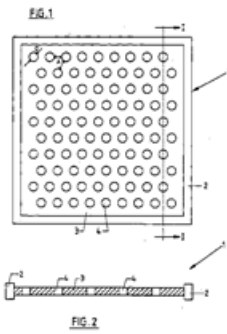

**B07B 1/48**

**Stretching devices for screens**

**Definition statement**

*This place covers:*

Illustrative example of subject matter classified in this group:

US-A-5221008

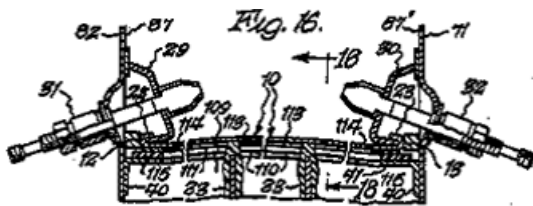

**B07B 1/485**

**{Devices for alternately stretching and sagging screening surfaces}**

**Definition statement**

*This place covers:*

Illustrative example of subject matter classified in this group:

DE-A1-3411719

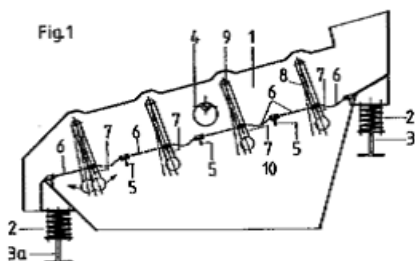

**B07B 1/49**

stretching more than one screen or screen section by the same or different stretching means

**Definition statement**

*This place covers:*

Illustrative example of subject matter classified in this group:

DE-C-608376

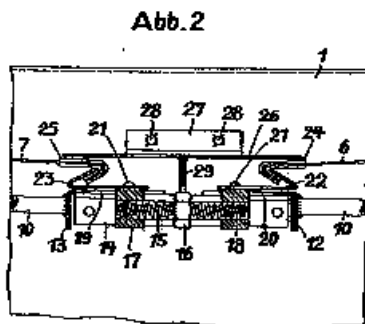
**B07B 1/522**

{with brushes}

**Definition statement**

*This place covers:*

Illustrative example of subject matter classified in this group:

FR-A-1059722

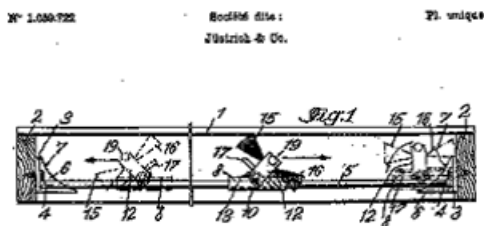
**B07B 1/524**

{the brushes being rotating}

**Definition statement**

*This place covers:*

Illustrative example of subject matter classified in this group:

DE-U1-20214115

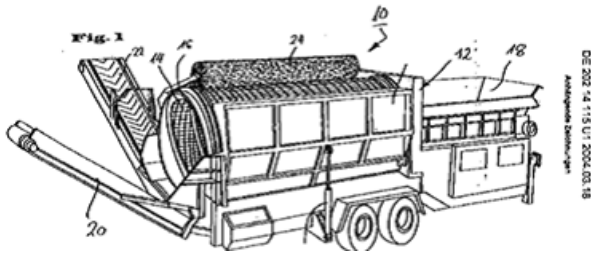

**B07B 1/526**

{with scrapers}

**Definition statement**

*This place covers:*

Illustrative example of subject matter classified in this group:

US-A-4289614

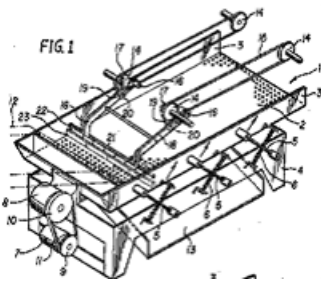

**B07B 1/528**

{the scrapers being rotating}

**Definition statement**

*This place covers:*

Illustrative example of subject matter classified in this group:

US-A-3863765

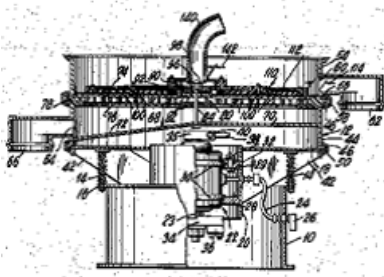

**B07B 1/54**

with beating devices

**Definition statement***This place covers:*

Illustrative example of subject matter classified in this group:

DE-A1-2223079

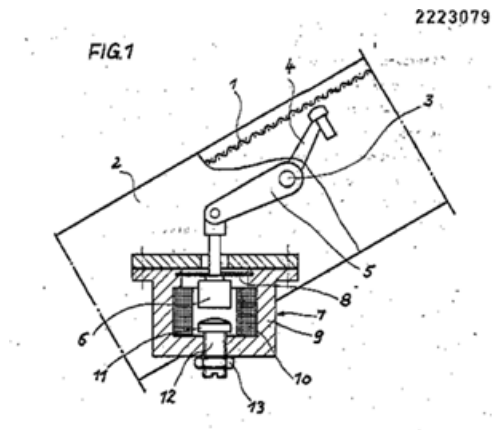
**B07B 1/55**

with fluid jets

**Definition statement***This place covers:*

Illustrative example of subject matter classified in this group:

GB-A-1193260

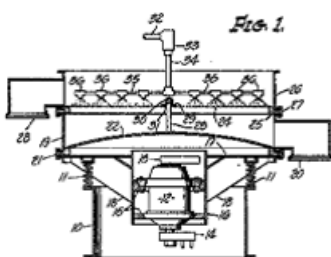
**B07B 1/56**

Heated screens

**Definition statement***This place covers:*

Illustrative example of subject matter classified in this group:

FR-A1-2567776

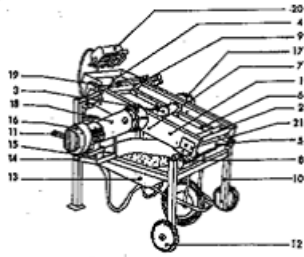

## **B07B 1/58**

**heated by heated fluid**

### **Definition statement**

*This place covers:*

Illustrative example of subject matter classified in this group:

DE-C-870935

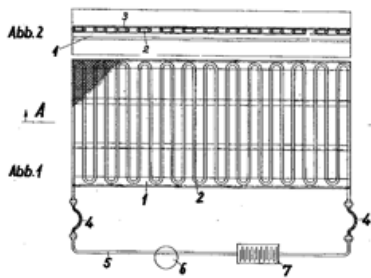

## **B07B 1/62**

**heated by direct electric heating**

### **Definition statement**

*This place covers:*

Illustrative example of subject matter classified in this group:

FR-E-61502

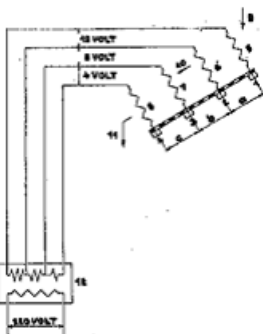

**B07B 4/00**

**Separating solids from solids by subjecting their mixture to gas currents  
(using tables or jigs [B03B 4/00](#))**

**Definition statement**

*This place covers:*

Illustrative example of subject matter classified in this group:

EP-A2-1072800

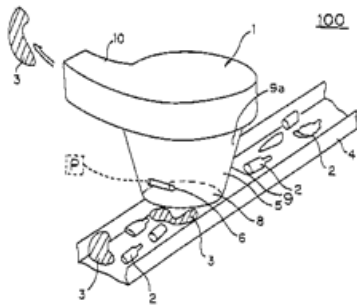
**B07B 4/02**

**while the mixtures fall**

**Definition statement**

*This place covers:*

Illustrative example of subject matter classified in this group:

WO-A1-2010/056220

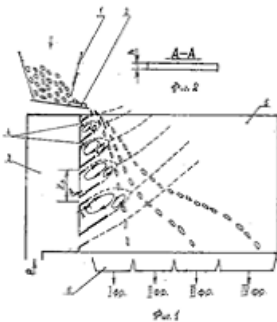
**B07B 4/025**

**{the material being slingered or fled out horizontally before falling, e.g. by dispersing elements}**

**Definition statement**

*This place covers:*

Illustrative example of subject matter classified in this group:

GB-A-1526050

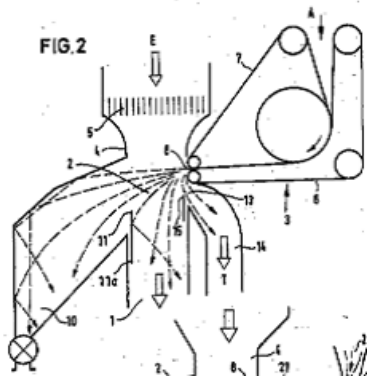

**B07B 4/04**

**in cascades**

**Definition statement**

*This place covers:*

Illustrative example of subject matter classified in this group:

US-A-4568453

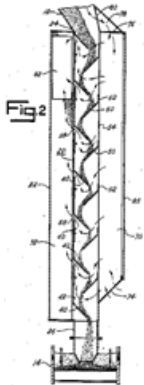

**B07B 4/06**

**using revolving drums**

**Definition statement**

*This place covers:*

Illustrative example of subject matter classified in this group:



US-A-4207177

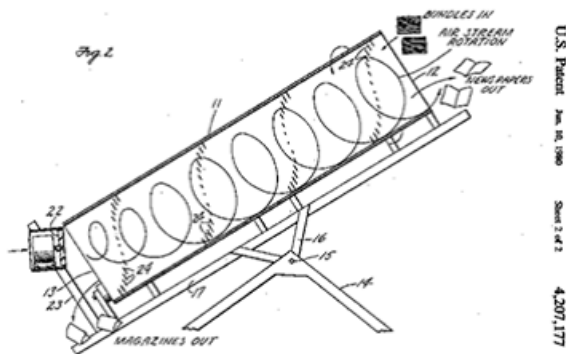

### B07B 4/08

while the mixtures are supported by sieves, screens, or like mechanical elements

#### Definition statement

*This place covers:*

Illustrative example of subject matter classified in this group:

DE-U1-202010004167

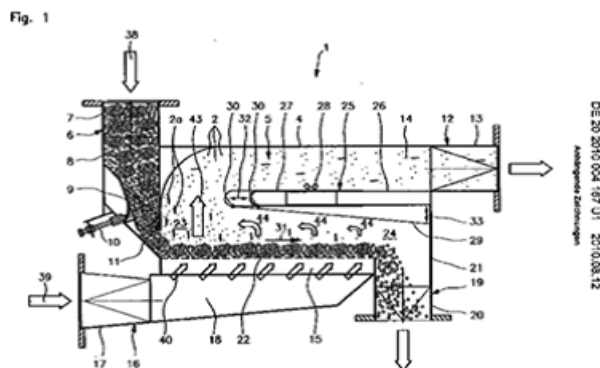

### B07B 7/00

Selective separation of solid materials carried by, or dispersed in, gas currents (sieves or filters for separating dispersed particles from gases or vapours [B01D](#))

#### Definition statement

*This place covers:*

Illustrative example of subject matter classified in this group:



**B07B 7/04**

by impingement against baffle separators

**Definition statement**

*This place covers:*

Illustrative example of subject matter classified in this group:

WO-A1-94/16995

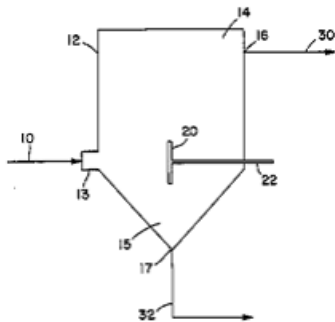
**B07B 7/06**

by impingement against sieves

**Definition statement**

*This place covers:*

Illustrative example of subject matter classified in this group:

WO-A1-95/32811

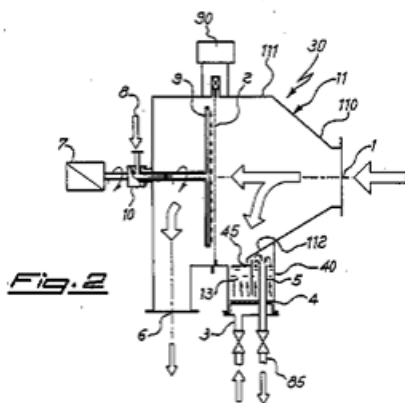
**B07B 7/08**

using centrifugal force (centrifuges [B04B](#); cyclones [B04C](#))

**Definition statement**

*This place covers:*

Illustrative example of subject matter classified in this group:

US-A-4159942

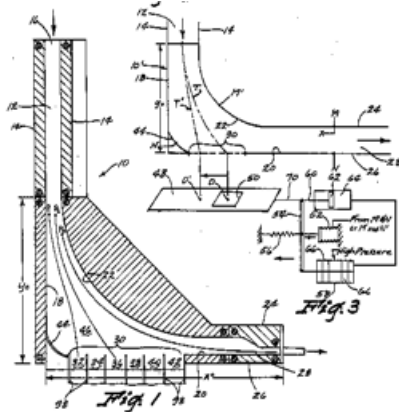

**B07B 7/083**

**generated by rotating vanes, discs, drums, or brushes**

**Definition statement**

*This place covers:*

Illustrative example of subject matter classified in this group:

DE-A1-19945646

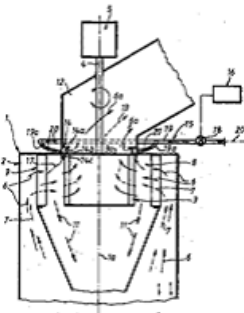

**B07B 7/086**

**generated by the winding course of the gas stream**

**Definition statement**

*This place covers:*

Illustrative example of subject matter classified in this group:

WO-A1-2006/126577

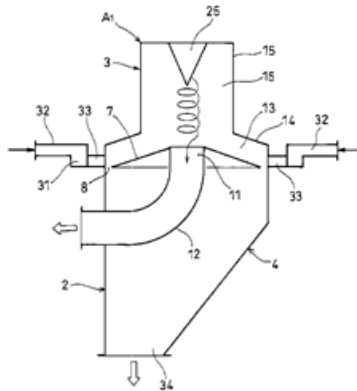

**B07B 7/10**

**having air recirculating within the apparatus**

**Definition statement**

*This place covers:*

Illustrative example of subject matter classified in this group:

EP-A2-0073567

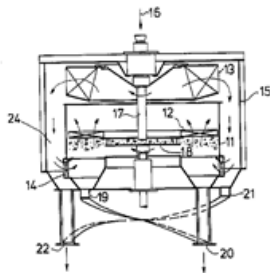

**B07B 7/12**

**with pulsating air currents**

**Definition statement**

*This place covers:*

Illustrative example of subject matter classified in this group:

US-A-3421619

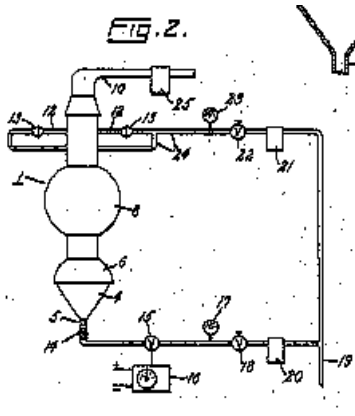

### **B07B 9/00**

**Combinations of apparatus for screening or sifting or for separating solids from solids using gas currents; General arrangement of plant, e.g. flow sheets**

#### **Definition statement**

*This place covers:*

Illustrative example of subject matter classified in this group:

US-A1-2002/0175113

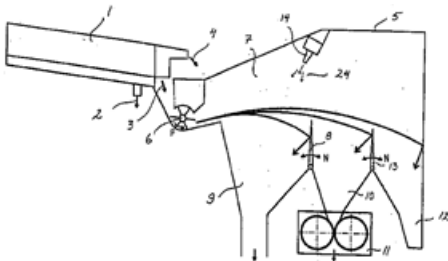

### **B07B 9/02**

**Combinations of similar or different apparatus for separating solids from solids using gas currents**

#### **Definition statement**

*This place covers:*

Illustrative example of subject matter classified in this group:

EP-A1-2206557

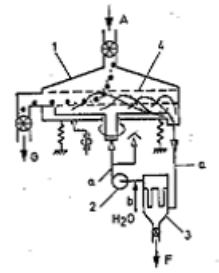

**B07B 11/04**

**Control arrangements**

**Definition statement**

*This place covers:*

Illustrative example of subject matter classified in this group:

US-B1-6883668

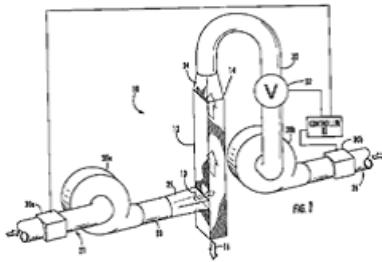

**B07B 11/06**

**Feeding or discharging arrangements**

**Definition statement**

*This place covers:*

Illustrative example of subject matter classified in this group:

FR-A-2553009

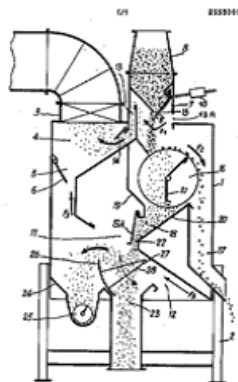

**B07B 11/08****Cleaning arrangements****Definition statement**

*This place covers:*

Illustrative example of subject matter classified in this group:

US-A-4913807

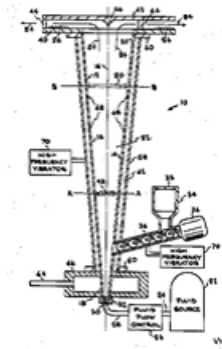
**B07B 13/003**

{Separation of articles by differences in their geometrical form or by difference in their physical properties, e.g. elasticity, compressibility, hardness}

**Definition statement**

*This place covers:*

Illustrative example of subject matter classified in this group:

WO-A1-03/013789

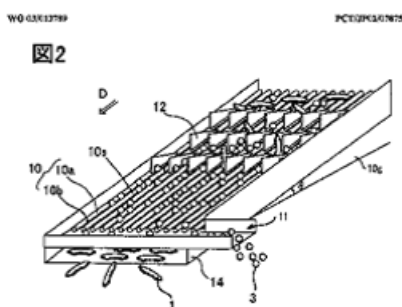
**B07B 13/006**

{Sorting molded pieces and runners}

**Definition statement**

*This place covers:*

Illustrative example of subject matter classified in this group:



FR-A1-2324379

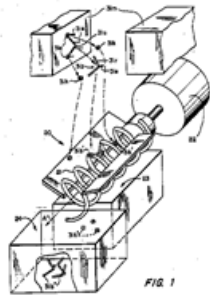

## **B07B 13/02**

**Apparatus for grading using pockets for taking out particles from aggregates**

### **Definition statement**

*This place covers:*

Illustrative example of subject matter classified in this group:

FR-A-748864

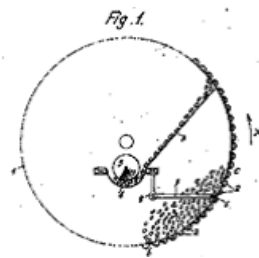

## **B07B 13/04**

**according to size**

### **Definition statement**

*This place covers:*

Illustrative example of subject matter classified in this group:

DE-A-4410871

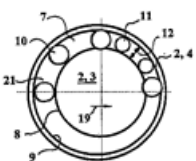
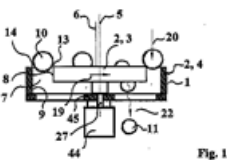

**B07B 13/05**

using material mover cooperating with retainer, deflector or discharger  
([B07B 13/065](#) - [B07B 13/075](#) take precedence)

**Definition statement**

*This place covers:*

Illustrative example of subject matter classified in this group:

FR-A-1028638

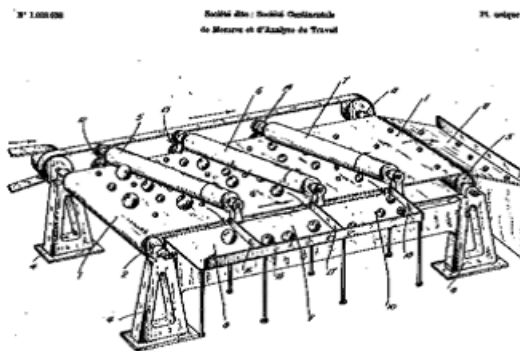
**B07B 13/065**

Apparatus for grading or sorting using divergent conveyor belts or cables

**Definition statement**

*This place covers:*

Illustrative example of subject matter classified in this group:

GB-A-594867

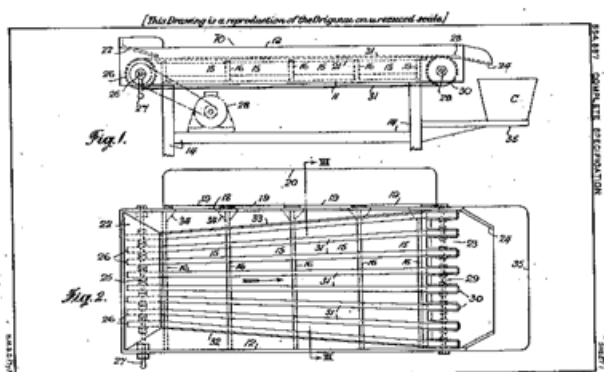
**B07B 13/07**

Apparatus in which aggregates or articles are moved along or past openings which increase in size in the direction of movement

**Definition statement**

*This place covers:*

Illustrative example of subject matter classified in this group:

FR-A-2545385

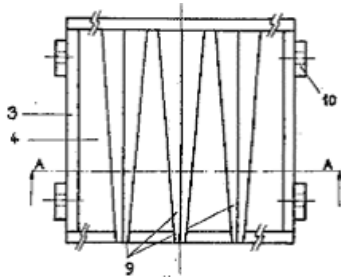

**B07B 13/075**

**Apparatus comprising moving article - receiving openings, the size of which varies as they move**

**Definition statement**

*This place covers:*

Illustrative example of subject matter classified in this group:

AU-B-592500

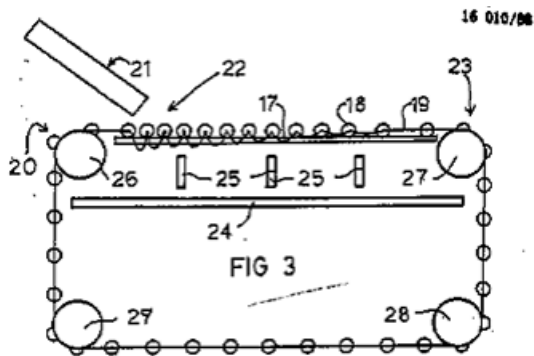

**B07B 13/08**

**according to weight ([B07B 13/10](#) takes precedence)**

**Definition statement**

*This place covers:*

Illustrative example of subject matter classified in this group:

US-A-5301816

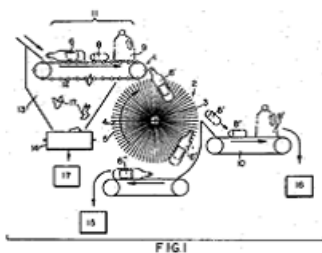

**B07B 13/10**

using momentum effects

**Definition statement**

*This place covers:*

Illustrative example of subject matter classified in this group:

WO-A1-2006/089326

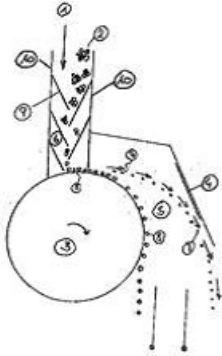
**B07B 13/11**

involving travel of particles over surfaces which separate by centrifugal force or by relative friction between particles and such surfaces, e.g. helical sorters

**Definition statement**

*This place covers:*

Illustrative example of subject matter classified in this group:

US-B1-6382427

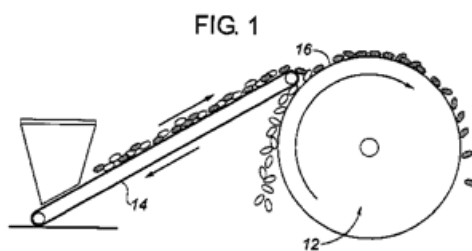
**B07B 13/113**

{shaking tables (for wet separating [B03B 5/04](#); tables with water impulse [B03B 5/70](#); pneumatic tables [B03B 4/02](#); moving screens [B07B 1/28](#))}

**Definition statement**

*This place covers:*

Illustrative example of subject matter classified in this group:

US-A1-2002117428

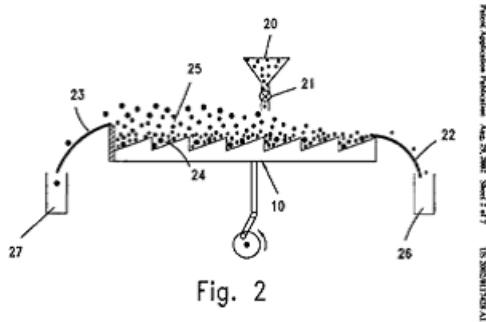

**B07B 13/116**

{stratification of dry granular material on a continuously travelling surface, e.g. belt conveyor (vanner for wet separation [B03B 5/08](#))}

**Definition statement**

*This place covers:*

Illustrative example of subject matter classified in this group:

US-A-3419143

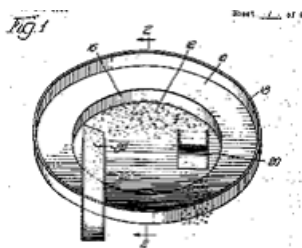

**B07B 13/16**

**Feed or discharge arrangements**

**Definition statement**

*This place covers:*

Illustrative example of subject matter classified in this group:

WO-A-03/068406

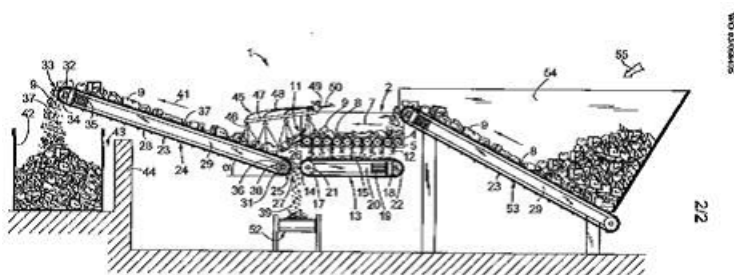

**FIG. 3**

**B07B 13/18****Control****Definition statement**

*This place covers:*

Illustrative example of subject matter classified in this group:

US-A-5024334

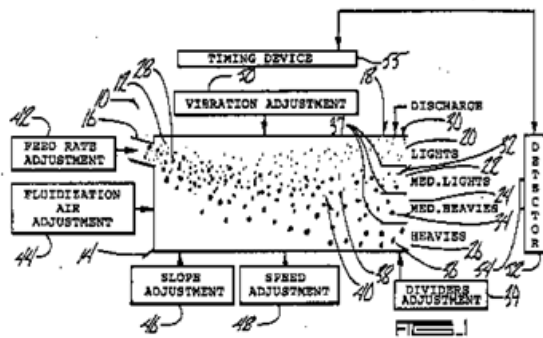
**B07B 15/00**

**Combinations of apparatus for separating solids from solids by dry methods applicable to bulk material, e.g. loose articles fit to be handled like bulk material (using wet methods [B03B 7/00](#); using gas currents [B07B 9/00](#))**

**Definition statement**

*This place covers:*

Illustrative example of subject matter classified in this group:

BE-A-898799

